

BAL-0067

Broadband Isolation Balun (300KHz to 67GHz)

DEVICE OVERVIEW

General Description

The BAL-0067 is a broadband balun, featuring high isolation and is hand-tuned for optimal phase and amplitude balance over a 300 kHz to 67 GHz bandwidth. It serves as an excellent choice for analog to digital converters, balanced receivers, baseband digital modulations, and signal integrity enhancement.

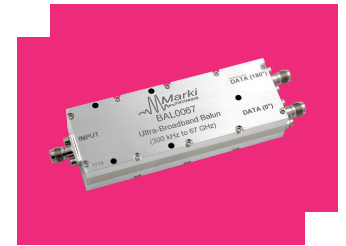

[Download s-parameters here](#)

Features

- 2:1 Impedance Ratio
- 300 kHz to 67 GHz Balun (Balanced to Unbalanced Transformer)
- Termination insensitive: Particularly suited to testing poorly matched or non 50 Ω devices or for extending 2 port VNAs for differential testing

Applications

- Analog to Digital Converters
- Balanced Receivers
- Baseband Digital Modulation
- Signal Integrity

Functional Block Diagram

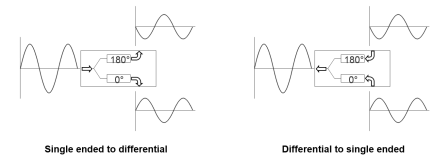

Part Ordering Options

Part Number	Description	Connectors	Green Status	Product Lifecycle	Export Classification
BAL-0067	Broadband Isolation Balun (300KHz to 67GHz)	<u>Standard</u>	REACH RoHS	Released	EAR99

Table Of Contents

- **Device Overview**
 - General Description
 - Features
 - Applications
 - Functional Block Diagram
- **Port Configuration and Functions**
 - Port Functions
- **Revision History**
- **Specifications**
 - Absolute Maximum Ratings
 - Package Information
 - Electrical Specifications
 - Typical Performance
 - Time Domain Performance Plots
 - Mixed Mode Scattering Parameters
- **Mechanical Data**
 - Outline Drawing

Revision History

Revision Code	Revision Date	Comment
-	2014-01-01	Datasheet initial Release
A	2016-01-01	Typical Performance Plots Updated
B	2019-10-01	Mixed Mode Scattering Parameters added
C	2019-11-01	RoHS Compliant assembly
D	2020-07-01	Specs Table Update
E	2020-10-01	Specs Table Update

Port Configuration and Functions

Port Functions

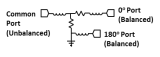
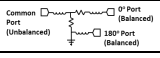
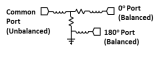
Port	Function	Connector Type	Description	DC Equivalent Circuit
0° Port (Balanced)	0° Port	1.85F	The 0° port is DC connected to the common port through a resistor and to ground through a resistor.	
180° Port (Balanced)	180° Port	1.85F	The 180° port is DC shorted to ground.	
Common (Unbalanced Port)	RF Input	1.85F	The common port is DC connected to the 0° port through a resistor and to ground through a resistor.	

Specifications

Absolute Maximum Ratings

Parameter	Maximum Rating	Unit
RF Power Handling	1	W

Package Information

Parameter	Details	Rating
Weight	-	125g
Dimensions	-	91.44 x 27.94 mm

Electrical Specifications

Specifications guaranteed from -55 to +100°C, measured in a 50Ω system.

Parameter	Test Conditions	Minimum Frequency (GHz)	Maximum Frequency (GHz)	Min	Typ	Max	Unit
Amplitude Balance	-	0.0003	67	-	0.7	2.1	dB
Common Mode Rejection	-	0.0003	67	20	27	-	dB
Group Delay	-	0.0003	67	-	520	-	ps
Insertion Loss as a Mode Converter	-	0.0003	35	-	3	6	dB
Insertion Loss as a Mode Converter	-	35	67	-	8.5	-	dB
Isolation	-	1	67	-	25	-	dB
Nominal Phase Shift	-	0.0003	67	-	180	-	°
Phase Balance	-	0.0003	67	-	4	12	°
Risetime/Falltime ¹	-	0.0003	67	-	2	-	ps
RMS Group Delay Ripple	-	0.0003	67	-	7	-	ps
VSWR (Input)	-	0.0003	67	-	1.5	-	
VSWR (Output)	-	0.0003	67	-	1.6	-	
Impedance Ratio	-	-	-	-	2:1	-	

^[1] Specified as 80%/20%. Calculated from $\tau_{balun2} = (\tau_{out2} - \tau_{in2})$

BAL-0067

Broadband Isolation Balun (300KHz to 67GHz)

Typical Performance

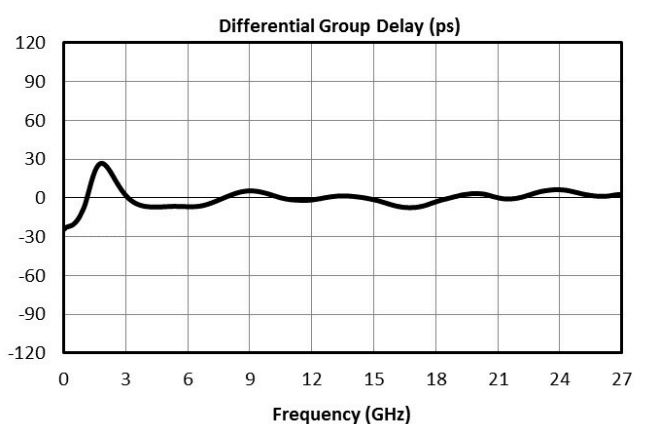
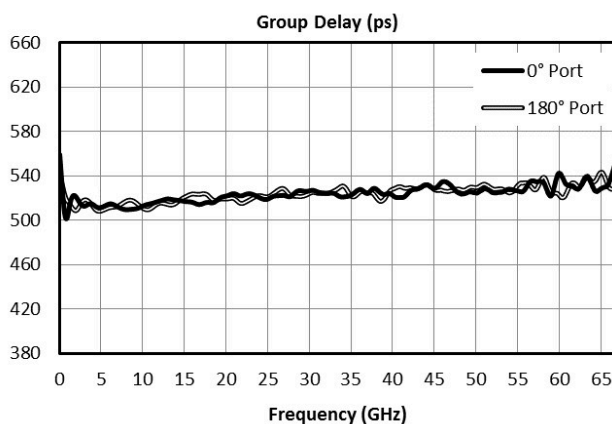
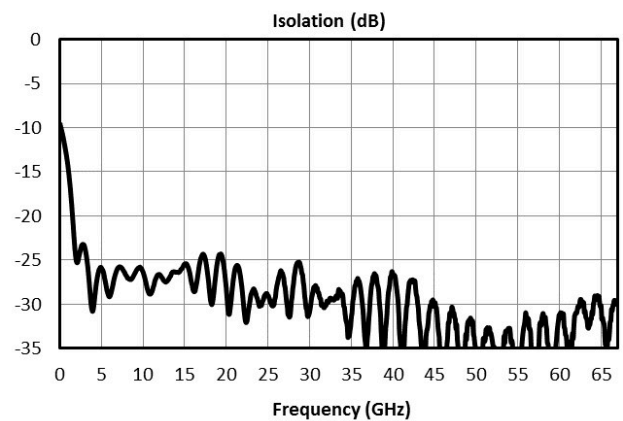
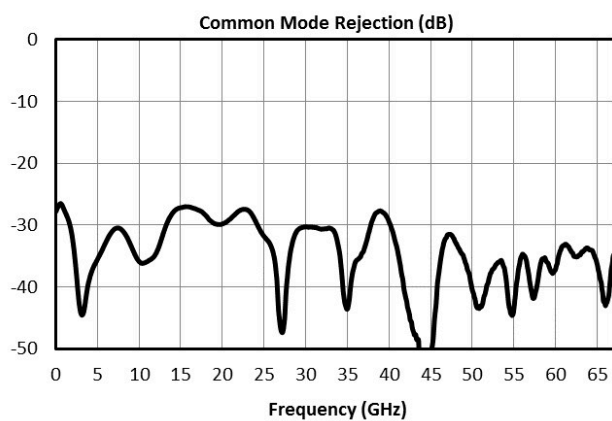
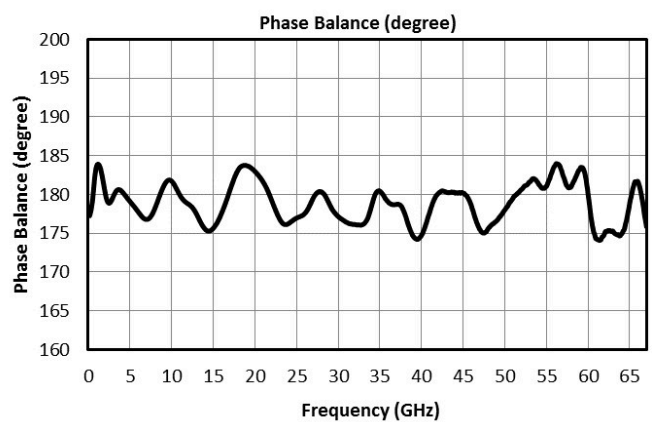
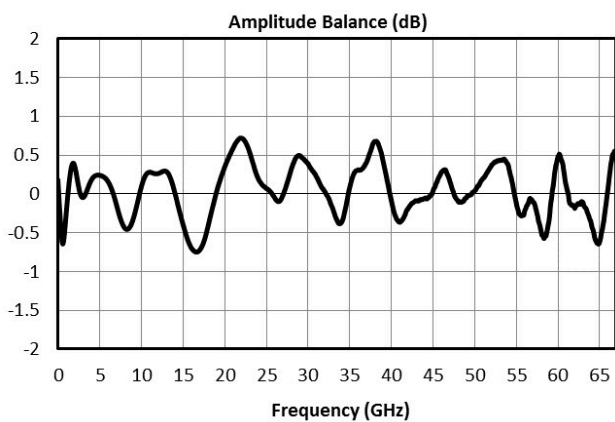
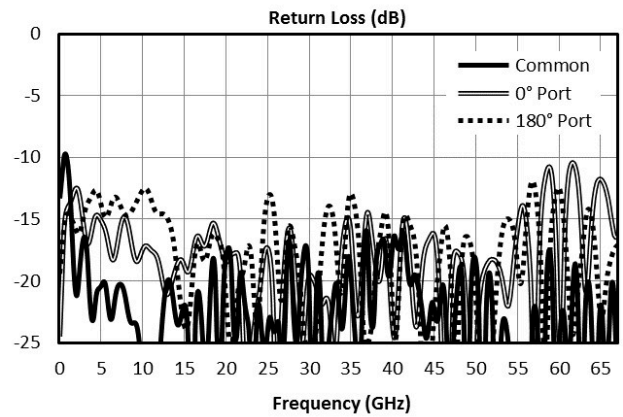
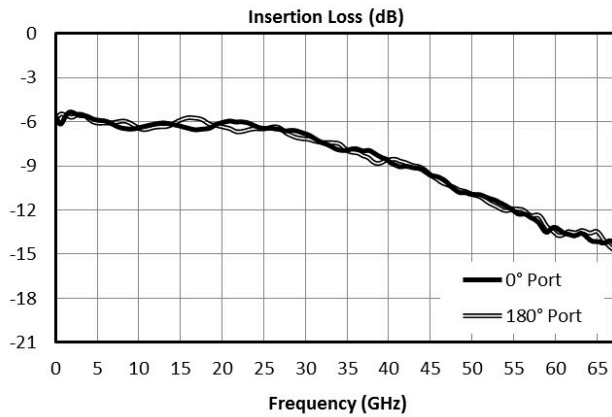

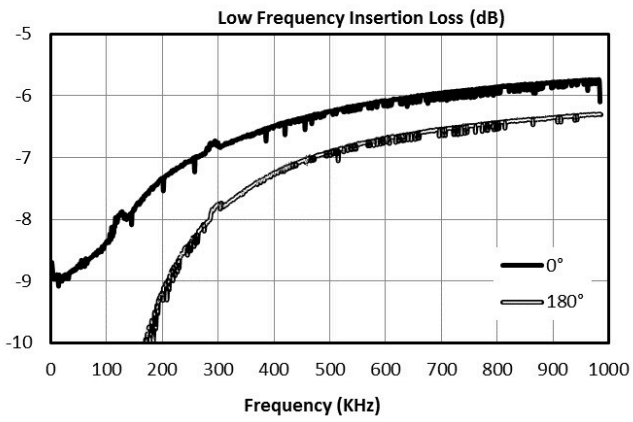

Time Domain Performance Plots

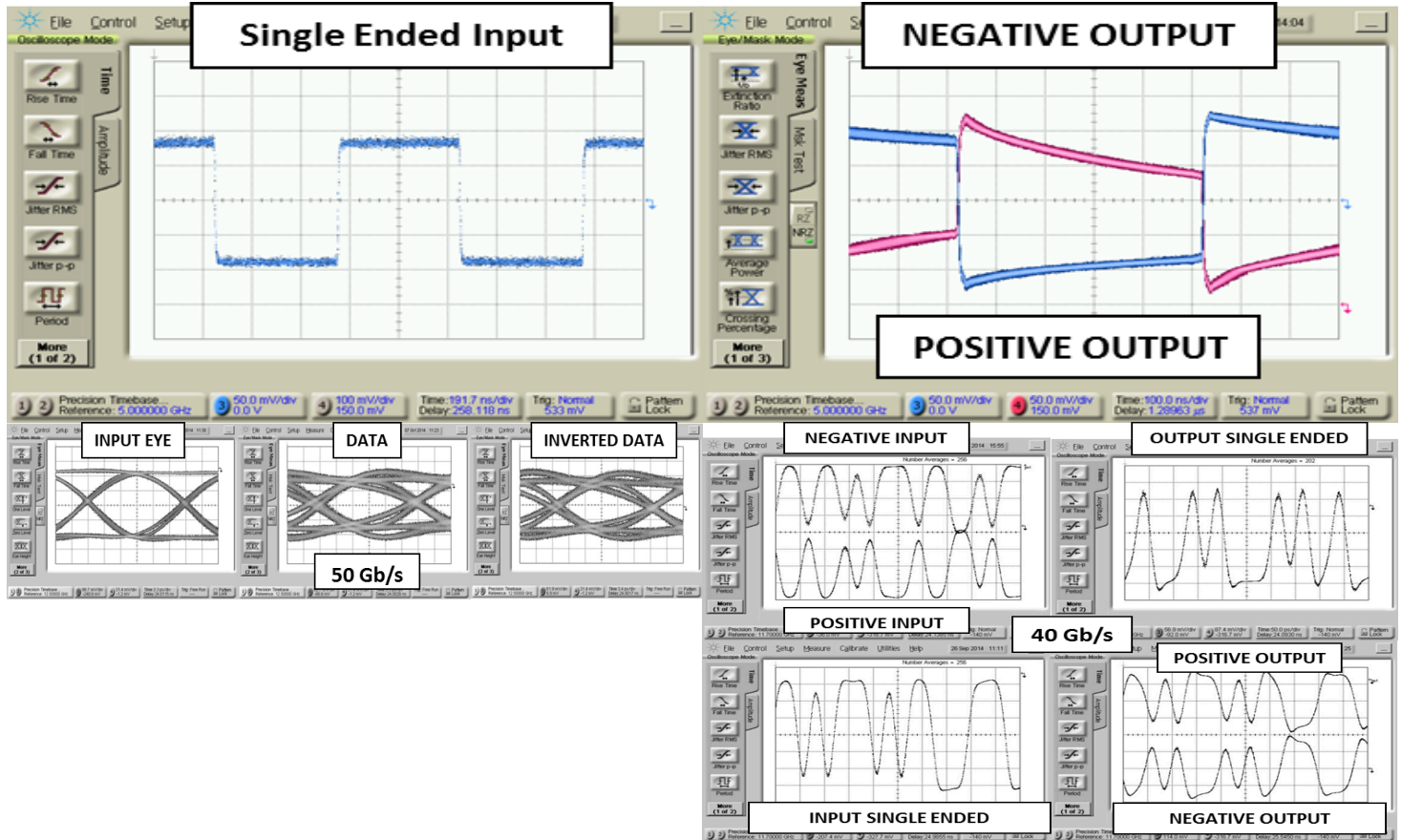

Mixed Mode Scattering Parameters

Mixed mode scattering parameters are used to characterize differential circuits. For baluns, this means that the 0° and 180° ports become a single 100Ω differential port and the common port remains the same 50Ω common port. The two-port s-parameters of the balun are then characterized based on differential (d), common mode (c), or single-ended (s) signals. For example: S12ds is the differential output response given a single ended input.

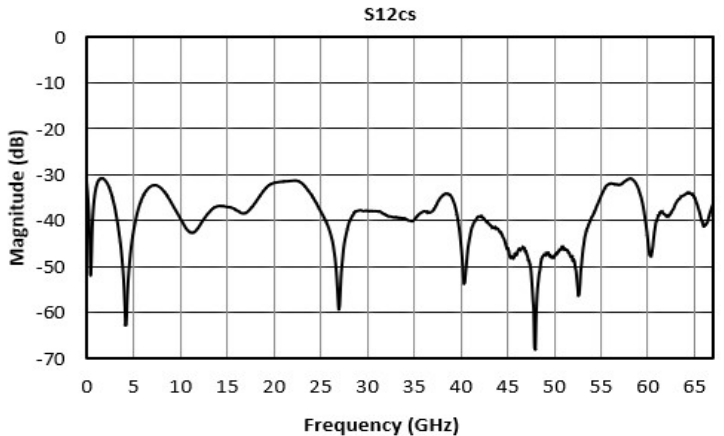
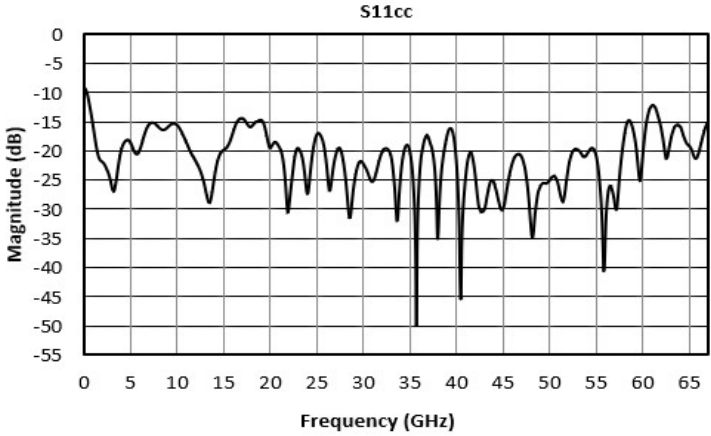
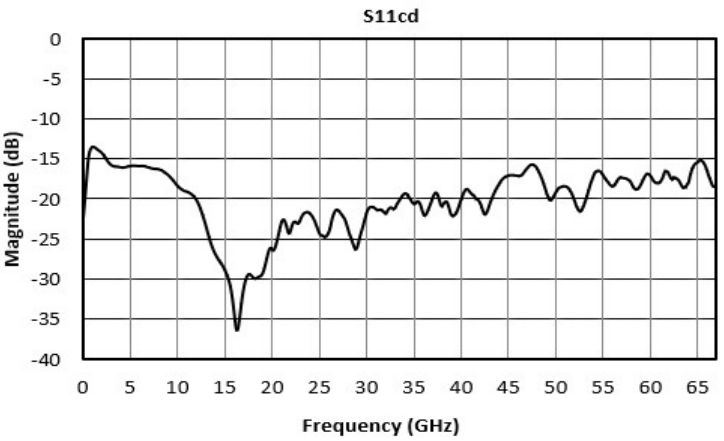
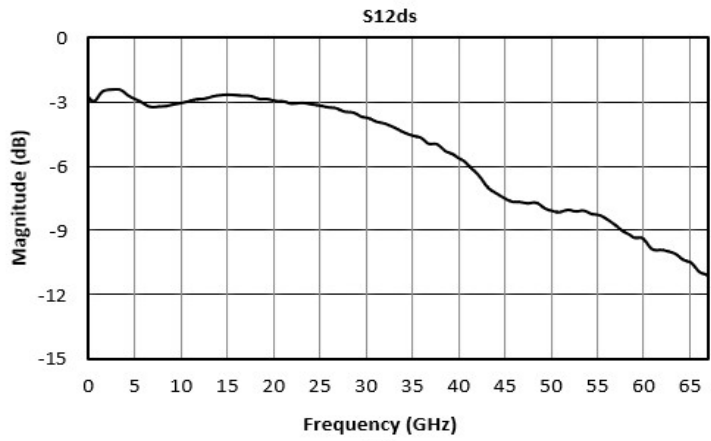
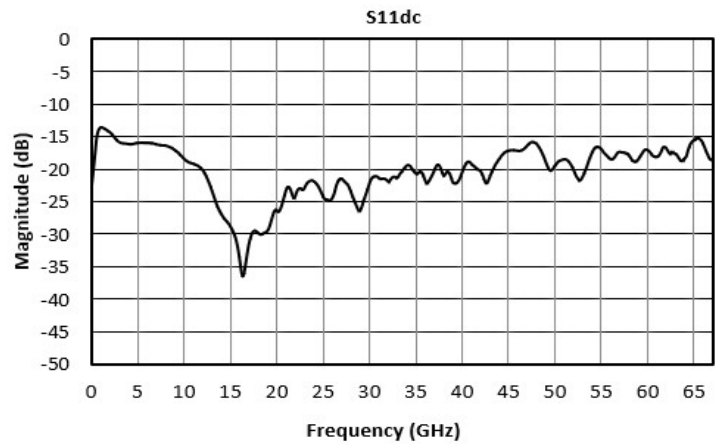
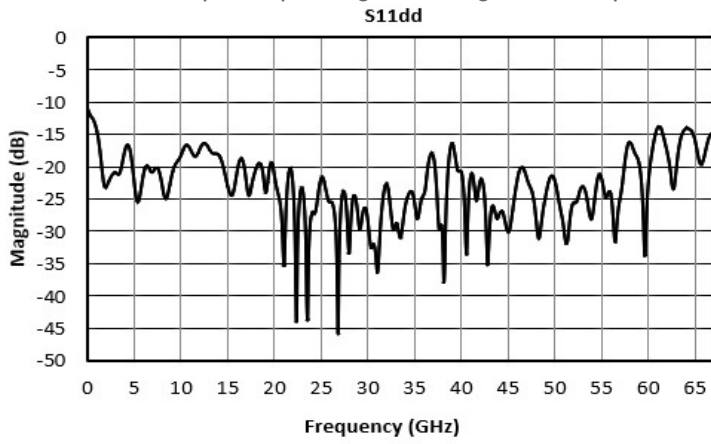

BAL-0067

Broadband Isolation Balun (300KHz to 67GHz)

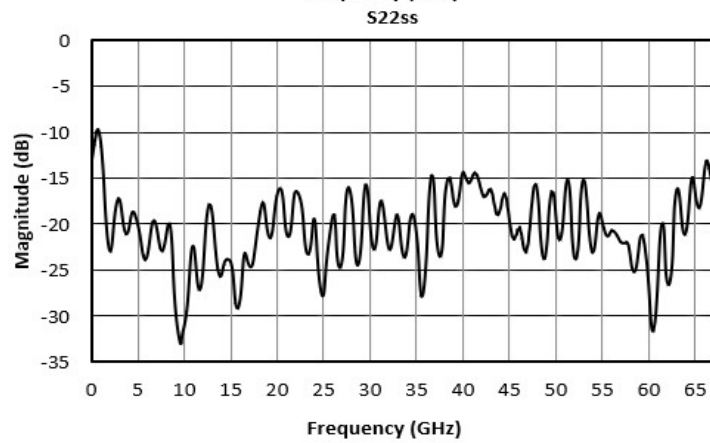
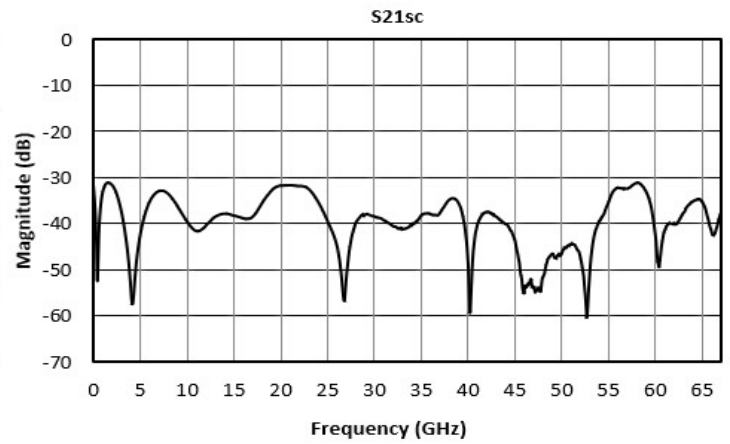
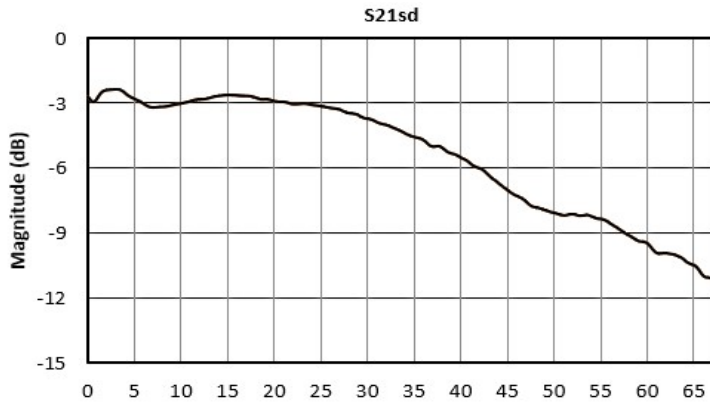

Mechanical Data

Outline Drawing

Download : [Outline 2D Drawing](#) | [Outline 3D Drawing](#) | [Outline 3D STP](#)

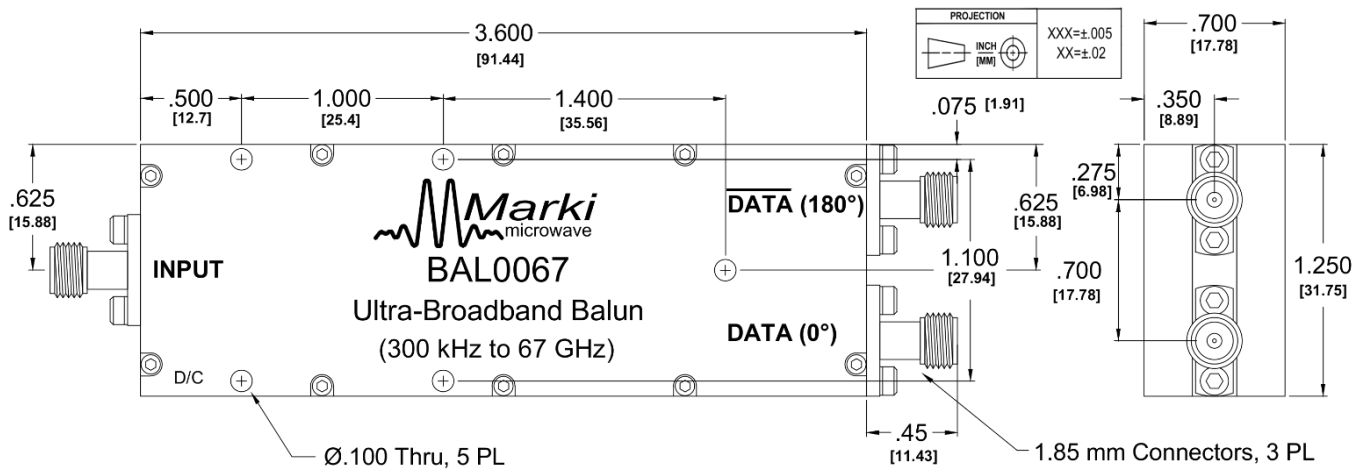

DISCLAIMER

MARKI MICROWAVE, LLC., ("MARKI") PROVIDES TECHNICAL SPECIFICATIONS AND DATA (INCLUDING DATASHEETS), APPLICATION OR OTHER DESIGN ADVICE, WEB TOOLS, AND OTHER INFORMATION AND RESOURCES "AS IS" AND WITH ALL FAULTS. MARKI DISCLAIMS ALL WARRANTIES, EXPRESS OR IMPLIED, INCLUDING, WITHOUT LIMITATION, ANY IMPLIED WARRANTIES OF MERCHANTABILITY, FITNESS FOR A PARTICULAR PURPOSE, OR NON-INFRINGEMENT.

These resources are intended for developers skilled in the art designing with Marki products. You are solely responsible for (1) selecting the appropriate products for your application, (2) designing, validating, and testing your application, and (3) ensuring your application meets applicable standards and other requirements. Marki makes no guarantee regarding the suitability of its products for any particular purpose, nor does Marki assume any liability whatsoever arising out of your use or application of any Marki product.

Marki grants you permission to use these resources only for development of an application that uses Marki products. Other reproduction or use of these resources is strictly prohibited. No license is granted to any other Marki intellectual property or to any third-party intellectual property. Marki reserves the right to make changes to the product(s) or information contained herein without notice.

MARKI MICROWAVE and T3 MIXER are trademarks or registered trademarks of Marki Microwave, LLC. All other trademarks used are the property of their respective owners.

© 2014, 2016, 2019 - 2020, Marki Microwave, LLC