

AMM-11078CH

0.01 – 40 GHz High Frequency Distributed Driver Amplifier

DEVICE OVERVIEW

General Description

The AMM-11078CH is a wideband GaAs distributed amplifier covering 0.01 to 40 GHz, delivering 17.5 dB small-signal gain with high output power and linearity. It provides up to +24 dBm saturated output power, with output IP3 up to +30.5 dBm. Operating from a +7V supply at 220 mA typical current, the amplifier is internally matched to 50 Ω at both the RF input and output ports. These features make it well-suited for wideband driver stages in RF/mmWave front ends, test and measurement instrumentation, electronic warfare, and general-purpose broadband gain block applications.

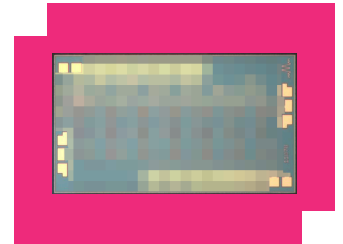

[Download s-parameters here](#)

Features

- High Frequency Wideband Operation
- High Saturated Output Power, +24 dBm Typical
- Positive Gain Slope
- Low Noise Figure, 3.8 dB Typical

Applications

- SATCOM
- 5G transceivers
- Test and Measurement Equipment

Functional Block Diagram

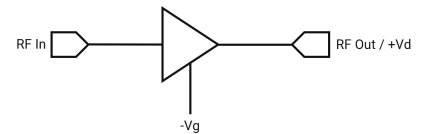

Part Ordering Options

Part Number	Description	Package	Green Status	Product Lifecycle	Export Classification
AMM-11078CH	0.01 – 40 GHz High Frequency Distributed Driver Amplifier	CH	REACH RoHS	Released	3A001.b.2.d

AMM-11078CH

0.01 – 40 GHz High Frequency Distributed Driver Amplifier

Table Of Contents

- **Device Overview**
 - General Description
 - Features
 - Applications
 - Functional Block Diagram
- **Port Configuration and Functions**
 - Port Diagram
 - Port Functions
- **Revision History**
- **Specifications**
 - Absolute Maximum Ratings
 - Package Information
 - Recommended Operating Conditions
 - Sequencing Requirements
 - Electrical Specifications
 - Typical Performance Plot
- **Die Mounting Recommendations**
 - Mounting and Bonding Recommendations
- **Operation**
 - Application Information
 - Application Circuit
 - Application Circuit Description
- **Mechanical Data**
 - Outline Drawing

Revision History

Revision Code	Revision Date	Comment
-	2026-04-10	Initial Release

Port Configuration and Functions

Port Diagram

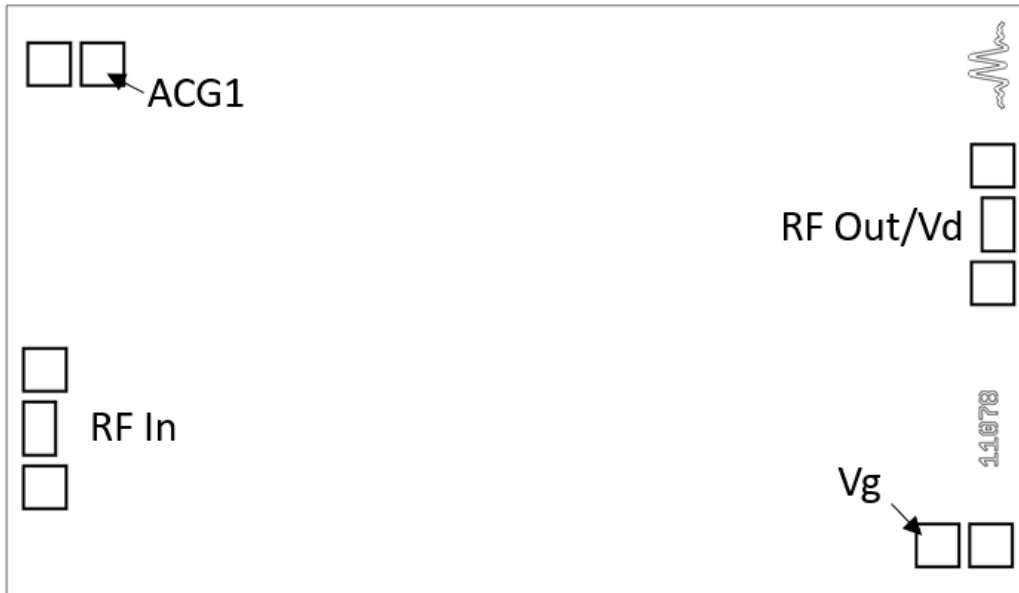

Port Functions

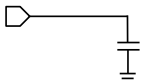
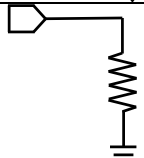
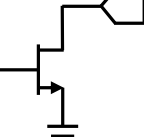
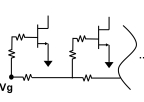
Port	Function	Description	DC Equivalent Circuit
ACG1	External Chip Capacitor	The ACG1 pad provides additional off chip bypass capacitance. A 0.1uF chip capacitor is recommended.	
GND	Ground	Bottom side must be connected to a DC/RF ground potential with high thermal and electrical conductivity.	GND ↓
RF In	RF Input	This is the RF Input port of the amplifier die. It is RF matched to 50 Ω and requires a DC blocking capacitor.	
RF Out	RF Output	The RF Out/ Vd pad supplies DC voltage to the drain of the amplifier and also acts as the RF output. This pad requires an external bias-tee.	
Vg	Gate Bias Voltage Pad	The Vg pad is connected resistively on chip. The user should apply between -0.15V and -0.35V to Vg pad before applying positive DC voltage to any Vd port. Lower (more negative) voltages on a Vg pad will result in lower drain current and lower small signal gain.	

Specifications

Absolute Maximum Ratings

The Absolute Maximum Ratings indicate limits beyond which damage may occur to the device. If these limits are exceeded, the device may become inoperable or have a reduced lifetime. This amplifier is designed and characterized in a 50Ω system, and operation in a reflective environment can cause performance degradation.

Parameter	Maximum Rating	Unit
Continuous Power Dissipation (PDISS) (at 85 °C case temp.)	3	W
Maximum Operating Temperature ¹	85	°C
Maximum Storage Temperature	150	°C
Max Junction Temperature for MTTF > 1E6 Hours	175	°C
Minimum Operating Temperature	-40	°C
Minimum Storage Temperature	-65	°C
Negative Bias Voltage (Vg)	-2	V
Positive Drain Supply Current (Id) (with RF Input)	250	mA
Positive Drain Supply Voltage (Vd)	12	V
RF Input Power	20	dBm
Thermal Resistance, θJC	15	°C/W

^[1] Low thermal resistance die attach to thermal ground is necessary for MTTF > 1x10⁶ hours

Package Information

Parameter	Details	Rating
ESD	< 250 Volts	HBM Class 0
Dimensions	-	1.38mm x 2.40mm

Recommended Operating Conditions

The Recommended Operating Conditions indicate the limits, inside which the device should be operated, to guarantee the performance given in Electrical Specifications. Operating outside these limits may not necessarily cause damage to the device, but the performance may degrade outside the limits of the electrical specifications. For limits, above which damage may occur, see Absolute Maximum Ratings. Power Supply DC current should be modified by changing bias voltage Vg to maintain junction temperature within MTTF target for given operating conditions.

Parameter	Min	Nominal	Max	Unit
Power Supply DC Voltage (Vd)	4	7	8	V
Power Supply DC Current (Id) (No RF Input)	150	220	230	mA
Ambient Temperature	-40	25	85	°C
Negative Bias Voltage (Vg)	-0.35	-0.25	-0.15	V
Input Power for Saturation	10	11	15	dBm

Sequencing Requirements

Turn-on Procedure:

1. Apply negative bias to Vg
2. Apply Vd

Turn-off Procedure:

1. Turn off Vd
2. Turn off Vg

Note: RF input power can be injected at any moment in the bias sequencing procedure.

Electrical Specifications

The electrical specifications apply at TA=+25°C in a 50Ω system. Min and Max limits apply only to our connectorized units and are guaranteed at TA=+25°C. Die are 100% DC tested and RF tested on a per lot basis

Parameter	Test Conditions	Minimum Frequency (GHz)	Maximum Frequency (GHz)	Min	Typ	Max	Unit
Small Signal Gain	Vd = +7V, Id = 220mA, Pin = -20dBm	0.01	40	-	17.5	-	dB
Input Return Loss	Vd = +7V, Id = 220mA, Pin = -20dBm	0.01	40	-	18	-	dB
Output Return Loss	Vd = +7V, Id = 220mA, Pin = -20dBm	0.01	40	-	19	-	dB
Reverse Isolation	Vd = +7V, Id = 220mA, Pin = -20dBm	0.01	40	-	55	-	dB
Noise Figure	Vd = +7V, Id = 220mA	0.01	40	-	3.8	-	dB
Saturated Output Power	Vd = +7V, Id = 220mA	0.01	15	-	25	-	dBm
Saturated Output Power	Vd = +7V, Id = 220mA	15	30	-	23.8	-	dBm
Saturated Output Power	Vd = +7V, Id = 220mA	30	40	-	21.7	-	dBm
Input P1dB	Vd = +7V, Id = 220mA	0.01	15	-	7	-	dBm
Input P1dB	Vd = +7V, Id = 220mA	15	30	-	7	-	dBm
Input P1dB	Vd = +7V, Id = 220mA	30	40	-	6	-	dBm
Output P1dB	Vd = +7V, Id = 220mA	0.01	15	-	22	-	dBm
Output P1dB	Vd = +7V, Id = 220mA	15	30	-	21.3	-	dBm
Output P1dB	Vd = +7V, Id = 220mA	30	40	-	19.5	-	dBm
Output IP3	Vd = +7V, Id = 220mA, Pin = -18dBm, 1MHz Tone Spacing	0.01	15	-	32.5	-	dBm
Output IP3	Vd = +7V, Id = 220mA, Pin = -18dBm, 1MHz Tone Spacing	15	30	-	29	-	dBm
Output IP3	Vd = +7V, Id = 220mA, Pin = -18dBm, 1MHz Tone Spacing	30	40	-	24	-	dBm
Input IP3	Vd = +7V, Id = 220mA, Pin = -18dBm, 1MHz Tone Spacing	0.01	40	-	15	-	dBm
Output IP2	Vd = +7V, Id = 220mA, Pin = -18dBm, 1MHz Tone Spacing	0.01	40	-	38	-	dBm
Input IP2	Vd = +7V, Id = 220mA, Pin = -18dBm, 1MHz Tone Spacing	0.01	40	-	22.5	-	dBm
Current Consumption	Vd = +7V	-	-	-	220	-	mA

Low frequency performance dependent on application circuit. For operation under 10MHz see application circuit notes.

AMM-11078CH

0.01 – 40 GHz High Frequency Distributed Driver Amplifier

Typical Performance Plot

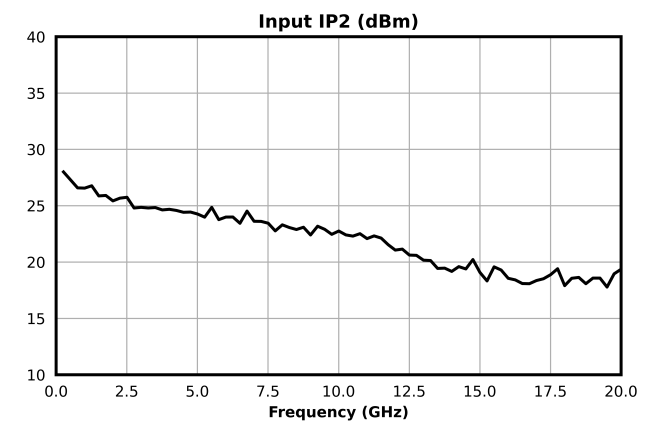
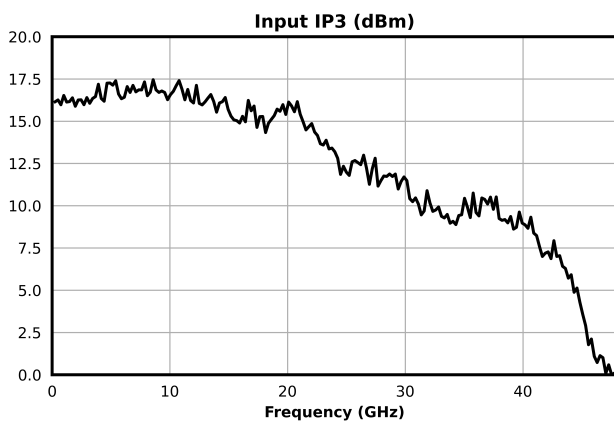
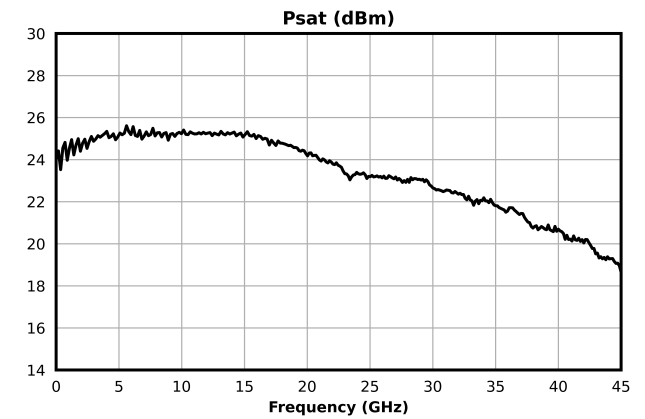
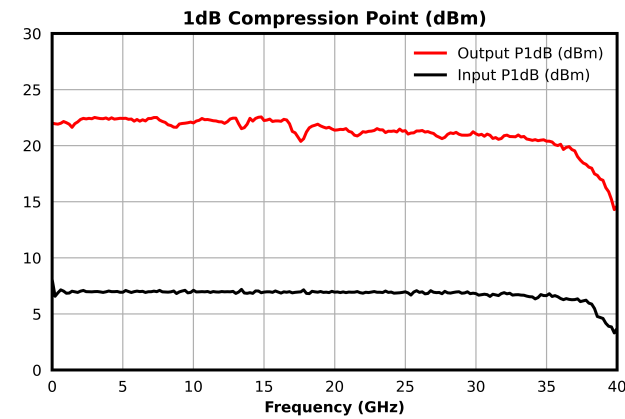
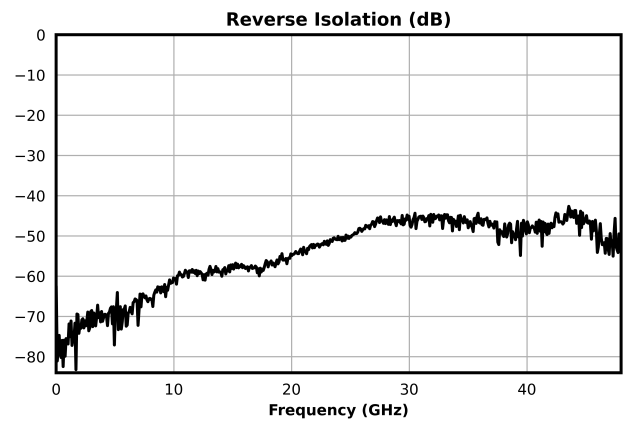
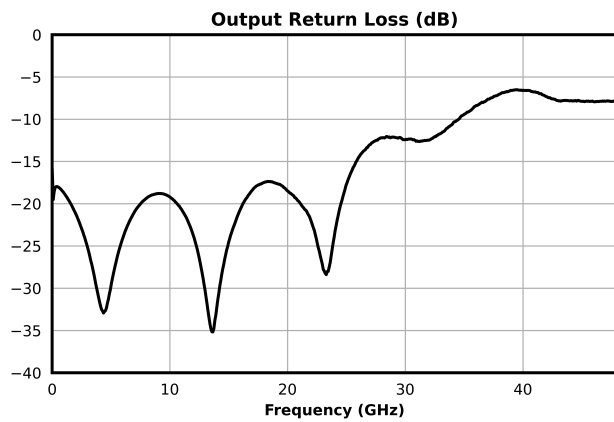
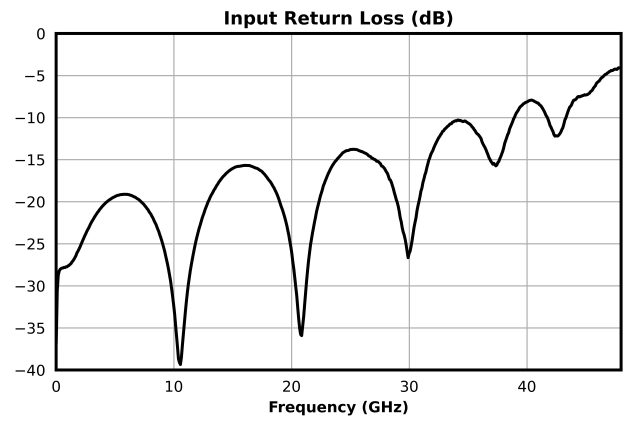
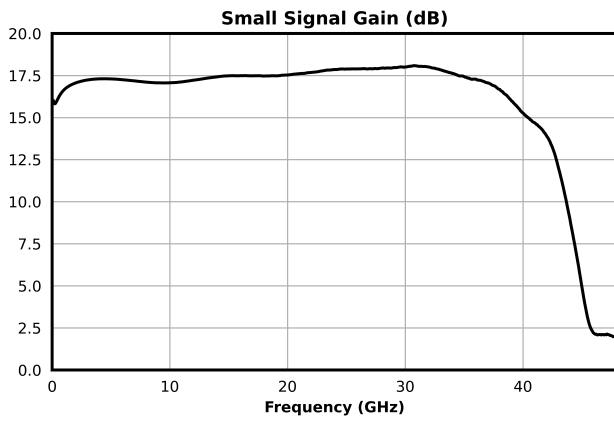

AMM-11078CH

0.01 – 40 GHz High Frequency Distributed Driver Amplifier

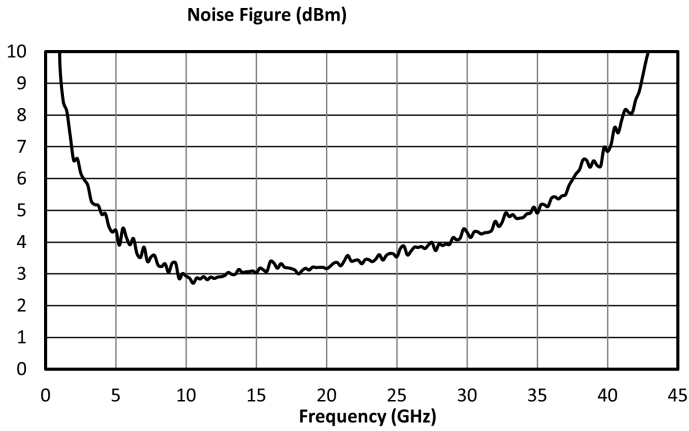
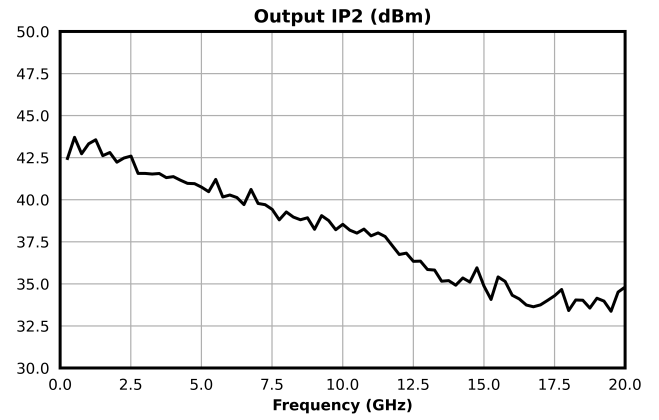
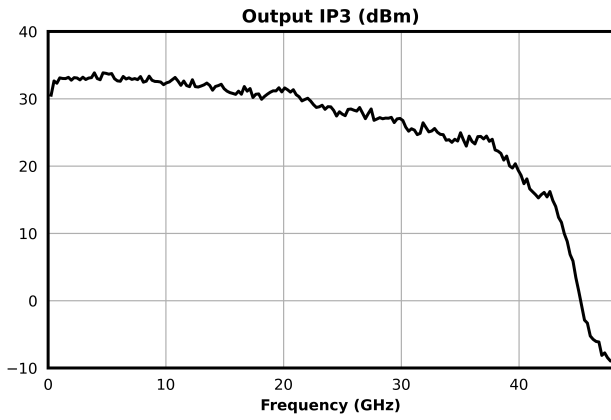

AMM-11078CH

0.01 – 40 GHz High Frequency Distributed Driver Amplifier

Application Information

Below are the recommended application circuits for the AMM-11078CH. This application circuit is used for the performance plots shown in this datasheet. However, each PCB layout and environment are different which may require minor modifications of the biasing network.

AMM-11078CH

0.01 – 40 GHz High Frequency Distributed Driver Amplifier

Application Circuit

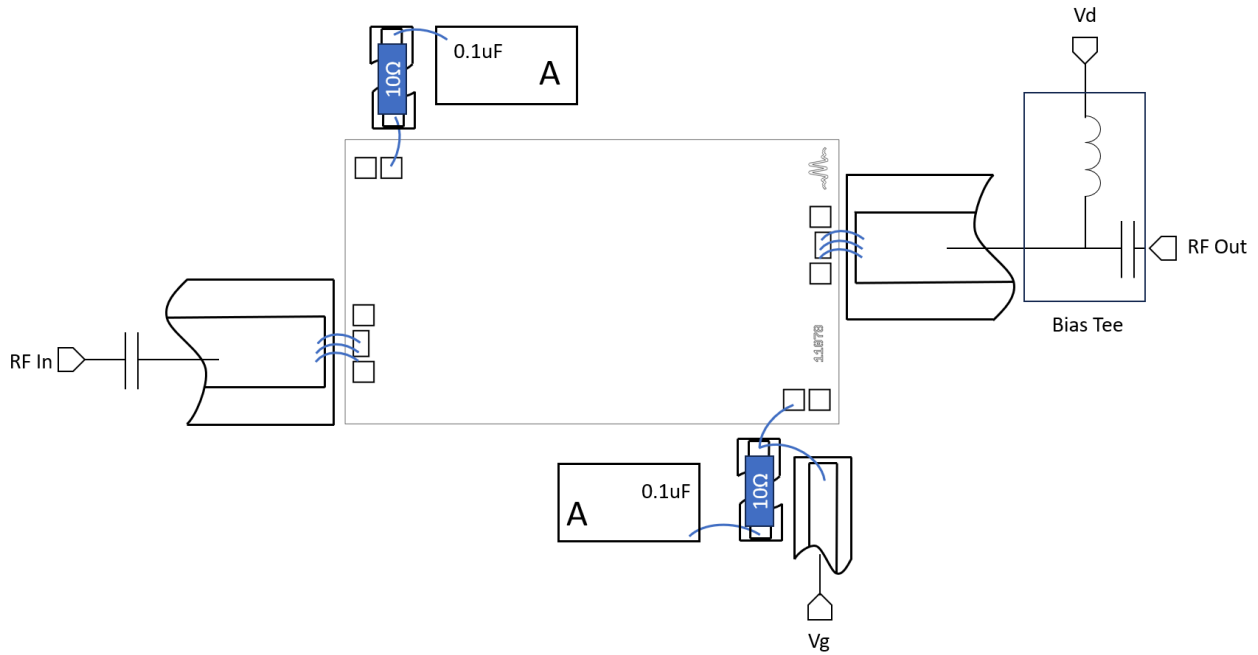

AMM-11078CH

0.01 – 40 GHz High Frequency Distributed Driver Amplifier

Application Circuit Description

Designator	Description	Sample Part Number
A	Presidio 0.1 μ F + 1800 pF Capacitor	MVB408DX104ZGH5R3
B	PPI 10 Ω Wire-bondable series resistor	PRT135-14x12x10A10R00FQE

AMM-11078CH

0.01 – 40 GHz High Frequency Distributed Driver Amplifier

Low Frequency Operation

The AMM-11078 can be used at low frequency approaching DC. Operation below 10MHz requires using larger bypass capacitors to provide AC ground across the frequency range of interest. It is recommended to place additional bypass capacitance in parallel with designator **A**. For example, if operation is desired to 100KHz at least 10uF of bypass capacitance is necessary.

Constant Drain Current vs. Constant Gate Voltage Operation

The AMM-11078 pHEMT amplifier can be biased with a constant gate and drain voltage, or with a constant drain current by regulating the gate voltage. Using a constant gate and drain voltage reduces circuit complexity, but has variable current consumption during operation. However, regulating the gate voltage using feedback circuitry which controls the drain current to a constant value minimizes unit-to-unit variation in gain, output power, and compression points.

Under small signal excitation at a fixed temperature, these two approaches are equivalent because the current draw versus frequency is relatively constant in small signal. However, they will diverge in large signal conditions, where the drain current is affected the input signal's frequency and power. The output power in saturation is relatively unchanged, as it is more strongly dependent on the drain voltage. However, output referred 1dB compression point will decrease by 2-3dB when operated with a constant drain current.

Die Mounting Recommendations

Mounting and Bonding Recommendations

Marki MMICs should be attached directly to a ground plane with conductive epoxy. The ground plane electrical impedance should be as low as practically possible. This will prevent resonances and permit the best possible electrical performance. Datasheet performance is only guaranteed in an environment with a low electrical impedance ground.

Mounting - To epoxy the chip, apply a minimum amount of conductive epoxy to the mounting surface so that a thin epoxy fillet is observed around the perimeter of the chip. Cure epoxy according to manufacturer instructions.

Wire Bonding - Ball or wedge bond with 0.025 mm (1 mil) diameter pure gold wire. Thermosonic wirebonding with a nominal stage temperature of 150 °C and a ball bonding force of 40 to 50 grams or wedge bonding force of 18 to 22 grams is recommended. Use the minimum level of ultrasonic energy to achieve reliable wirebonds. Wirebonds should be started on the chip and terminated on the package or substrate. Bond wire inductance will improve return loss. Bond wire inductance in the range of 30pH to 200pH will improve performance.

Circuit Considerations – 50 Ω transmission lines should be used for all high frequency connections in and out of the chip. Wirebonds should be kept as short as possible, with multiple wirebonds recommended for higher frequency connections to reduce parasitic inductance. In circumstances where the chip more than .001" thinner than the substrate, a heat spreading spacer tab is optional to further reduce bondwire length and parasitic inductance.

AMM-11078CH

0.01 – 40 GHz High Frequency Distributed Driver Amplifier

Mechanical Data

Outline Drawing

Download : [Outline 2D Drawing](#)

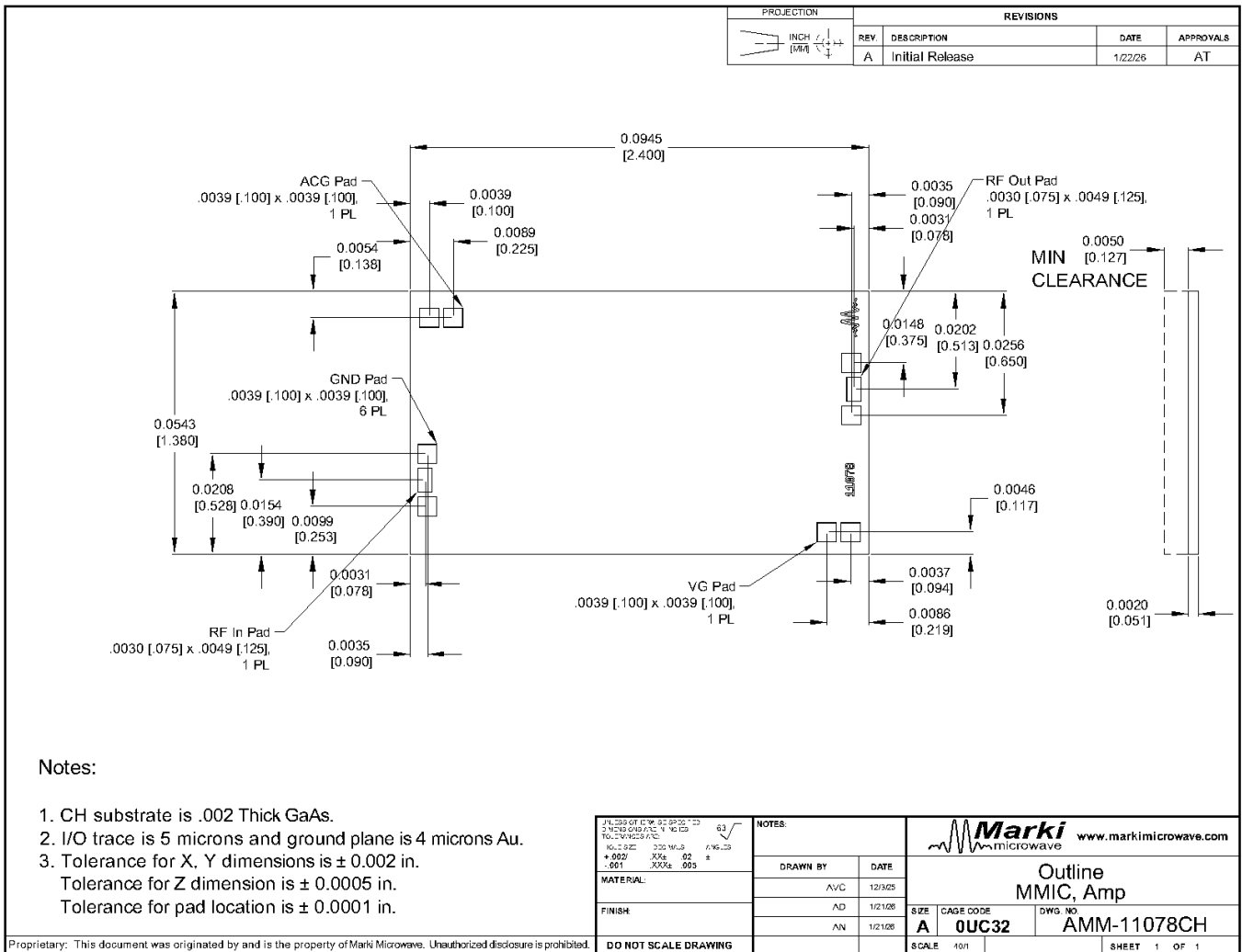

It is recommended to handle this die from the perimeter. Handling keep out zone is 100um inset from die perimeter.

DISCLAIMER

MARKI MICROWAVE, LLC., (“MARKI”) PROVIDES TECHNICAL SPECIFICATIONS AND DATA (INCLUDING DATASHEETS), APPLICATION OR OTHER DESIGN ADVICE, WEB TOOLS, AND OTHER INFORMATION AND RESOURCES “AS IS” AND WITH ALL FAULTS. MARKI DISCLAIMS ALL WARRANTIES, EXPRESS OR IMPLIED, INCLUDING, WITHOUT LIMITATION, ANY IMPLIED WARRANTIES OF MERCHANTABILITY, FITNESS FOR A PARTICULAR PURPOSE, OR NON-INFRINGEMENT.

These resources are intended for developers skilled in the art designing with Marki products. You are solely responsible for (1) selecting the appropriate products for your application, (2) designing, validating, and testing your application, and (3) ensuring your application meets applicable standards and other requirements. Marki makes no guarantee regarding the suitability of its products for any particular purpose, nor does Marki assume any liability whatsoever arising out of your use or application of any Marki product.

Marki grants you permission to use these resources only for development of an application that uses Marki products. Other reproduction or use of these resources is strictly prohibited. No license is granted to any other Marki intellectual property or to any third-party intellectual property. Marki reserves the right to make changes to the product(s) or information contained herein without notice.

MARKI MICROWAVE and T3 MIXER are trademarks or registered trademarks of Marki Microwave, LLC. All other trademarks used are the property of their respective owners.

© 2026, Marki Microwave, LLC