

ADM-8558CH

DC - 20 GHz Distributed Amplifier

DEVICE OVERVIEW

General Description

The ADM-8558 is a wideband distributed low noise amplifier capable of providing 16 dB gain and +23 dBm OIP3 from DC to 20 GHz and a low 1.8 dB typical noise figure from 7 to 15 GHz. The ADM-8558 is an ideal linear signal amplifier for applications requiring low power consumption and small form-factors. ADM-8558 is available in bare die and connectorized module forms. The amplifier has excellent return losses and gain flatness.



[Download s-parameters here](#)

Features

- 16 dB typical gain
- 1.8 dB typical noise figure
- Single Supply, Positive Only Bias
- Low power consumption

Applications

- Test and Measurement Equipment
- Radar and satellite communications

Functional Block Diagram

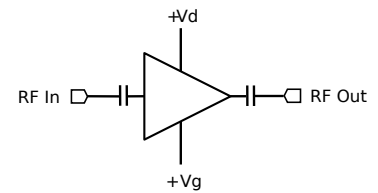

Part Ordering Options

Part Number	Description	Package	Connectors	Green Status	Product Lifecycle	Export Classification
ADM-8558PC	0.005 - 20 GHz Distributed Amplifier	PC	Standard	RoHS REACH	Released	EAR99
ADM-8558CH	DC - 20 GHz Distributed Amplifier	CH	-	RoHS REACH	Released	EAR99

Table Of Contents

- **Device Overview**
 - General Description
 - Features
 - Applications
 - Functional Block Diagram
- **Port Configuration and Functions**
 - Port Diagram
 - Port Functions
- **Revision History**
- **Specifications**
 - Absolute Maximum Ratings
 - Package Information
 - Recommended Operating Conditions
 - Sequencing Requirements
 - Electrical Specifications
 - Typical Performance Plots
 - ADM-8558PC Typical Performance Plots
- **Die Mounting Recommendations**
 - Mounting and Bounding Recommendations
- **Operation**
 - Application Information
 - Application Circuit
- **Mechanical Data**
 - Outline Drawing

Revision History



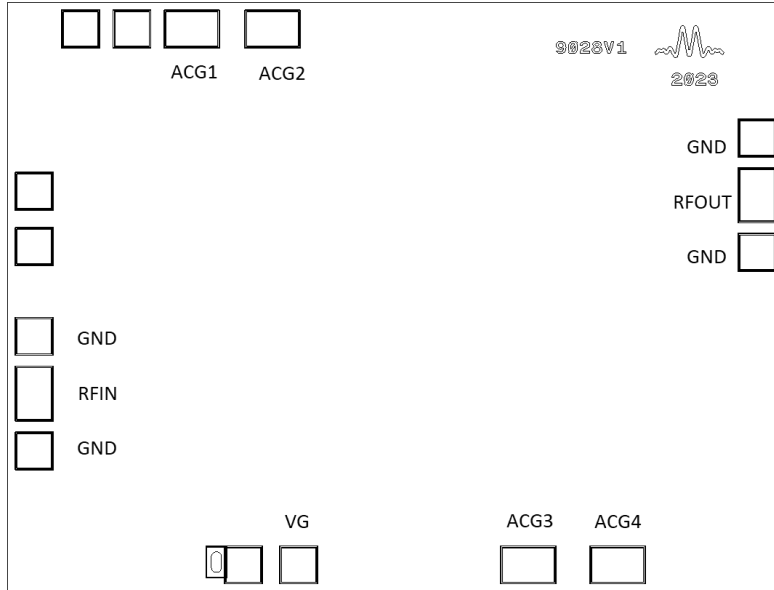

Revision Code	Revision Date	Comment
-	2023-07-01	Datasheet Initial Release
A	2024-08-02	Updated according to ECN# 24031. Updated voltage limits, performance plots, application circuit and outline drawing.

Port Configuration and Functions

Port Diagram

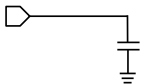

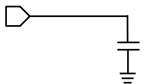
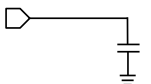
Port Functions

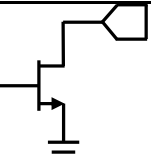
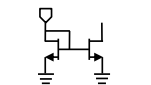
Port	Function	Description	DC Equivalent Circuit
ACG1	External Chip Capacitor	The ACG1 pad provides additional off chip bypass capacitance. A 100pF chip capacitor is recommended.	
ACG2	External Chip Capacitor	The ACG2 pad provides additional off chip bypass capacitance. A 0.1uF chip capacitor is recommended.	
ACG3	External Chip Capacitor	The ACG3 pad provides additional off chip bypass capacitance. A 0.1uF chip capacitor is recommended.	
ACG4	External Chip Capacitor	The ACG4 pad provides additional off chip bypass capacitance. A 100pF chip capacitor is recommended.	
GND	Ground	Housing or ground lug must be connected to a DC/RF ground potential with high thermal and electrical conductivity.	
RF In	RF Input	This is the amplifier's RF Input port. It is RF matched to 50 Ω and requires an DC blocking capacitors	
Vd/RF Out	Drain Supply / RF Output	The VD pin supplies DC voltage to the drain of the amplifier IC. This pin is nominally set at +6V.	
Vg	Gate Bias Pin	The VG pad provides a required positive bias which supplies the current mirror. A higher voltage results in a higher current draw through the VD / RF Out port. This port should be set to +3V for normal operation.	

Specifications

Absolute Maximum Ratings

The Absolute Maximum Ratings indicate limits beyond which damage may occur to the device. If these limits are exceeded, the device may become inoperable or have a reduced lifetime. Reliability limits are individual, instantaneous catastrophic limits only. Functional operation limits are indicated below. Operation of the device at multiple absolute maximum limits or for extended periods at a single limit can cause degradation and damage to the device

Parameter	Maximum Rating	Unit
Drain Current (Id) (No RF Applied)	80	mA
Drain Supply Voltage (Vd)	8.5	V
Gate Current (Ig)	10	mA
Gate Supply Voltage (Vg)	6.5	V
Maximum Operating Temperature for MTTF > 1E6 hours	85	°C
Maximum Storage Temperature	125	°C
Minimum Operating Temperature for MTTF > 1E6 hours	-40	°C
Minimum Storage Temperature	-55	°C
RF Power Handling	15	dBm

Package Information

Parameter	Details	Rating
Dimensions	-	1.75 x 2.3 mm

Recommended Operating Conditions

The Recommended Operating Conditions indicate the limits, inside which the device should be operated, to guarantee the performance given in Electrical Specifications. Operating outside these limits may not necessarily cause damage to the device, but the performance may degrade outside the limits of the electrical specifications. For limits, above which damage may occur, see Absolute Maximum Ratings.

Parameter	Min	Nominal	Max	Unit
Ambient Temperature	-40	25	85	°C
Power Supply DC Voltage (Vd)	6	6	8	V
Power Supply DC Current (Id) (No RF Input)	50	50	70	mA
Gate Bias DC Voltage (Vg)	3	3	4	V

Sequencing Requirements

There is no sequencing required to power up or power down the amplifier.

Electrical Specifications

Unless otherwise specified, electrical specifications apply at TA=+25°C, Vd = 6V, Vg = 3V.

Parameter	Test Conditions	Minimum Frequency (GHz)	Maximum Frequency (GHz)	Min	Typ	Max	Unit
Output Power	-	2	24	-	19	-	dBm
DC Supply Quiescent Current (Idq)	Vd = 6V, Vg = 3V, No RF input	0.004	20	-	50	-	mA
Input Return Loss	Vd = 6V, Vg = 3V, Pin = -20dBm	0.005	20	-	21	-	dB
Noise Figure	Vd = 6V, Vg = 3V, Pin = -20dBm	0.005	7	-	3.8	-	dB
Noise Figure	Vd = 6V, Vg = 3V, Pin = -20dBm	7	15	-	1.8	-	dB
Noise Figure	Vd = 6V, Vg = 3V, Pin = -20dBm	15	20	-	2.8	-	dB
Output IP3	Vd = 6V, Vg = 3V, Pin = -20dBm	0.004	20	-	23	-	dBm
Output P1dB	Vd = 6V, Vg = 3V	0.005	20	-	14	-	dBm
Output Return Loss	Vd = 6V, Vg = 3V, Pin = -20dBm	0.004	20	-	23	-	dB
Reverse Isolation	Vd = 6V, Vg = 3V, Pin = -20dBm	0.004	20	-	40	-	dB
Small Signal Gain	Vd = 6V, Vg = 3V, Pin = -20dBm	0.005	20	14	16	-	dB

Typical Performance Plots

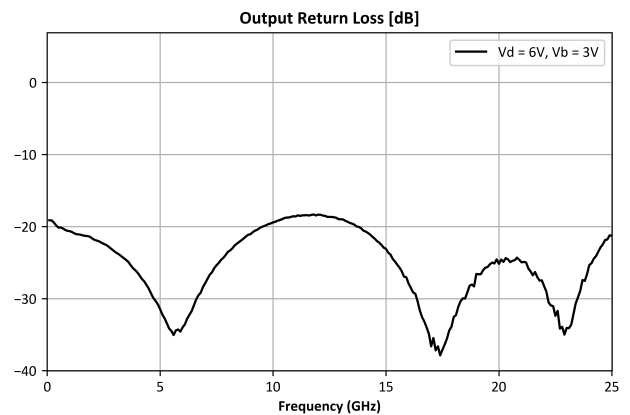
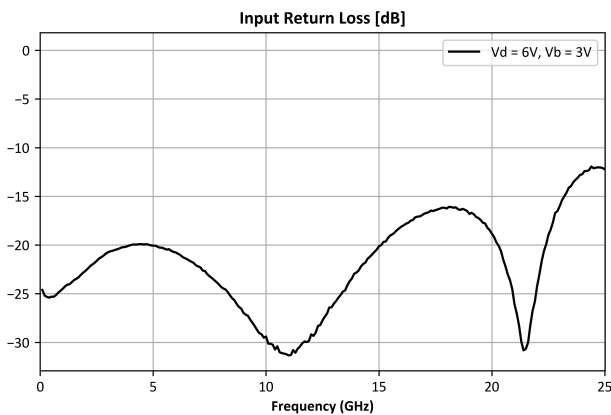
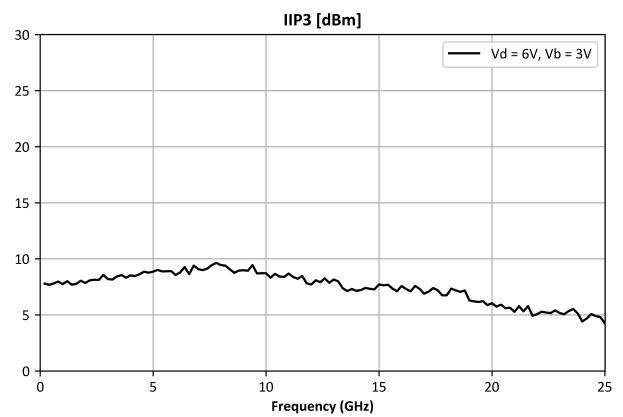
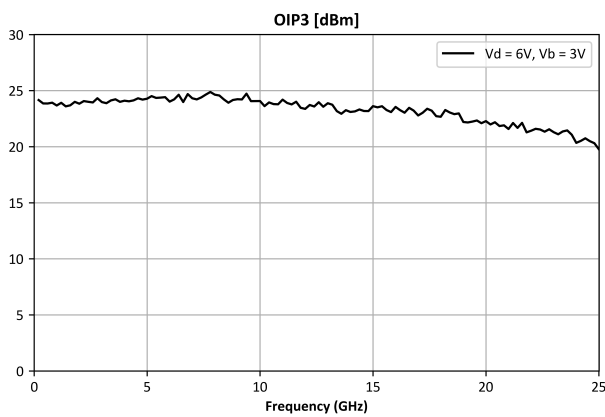
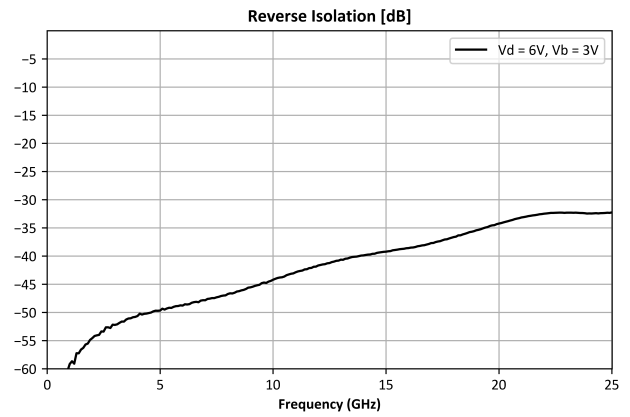
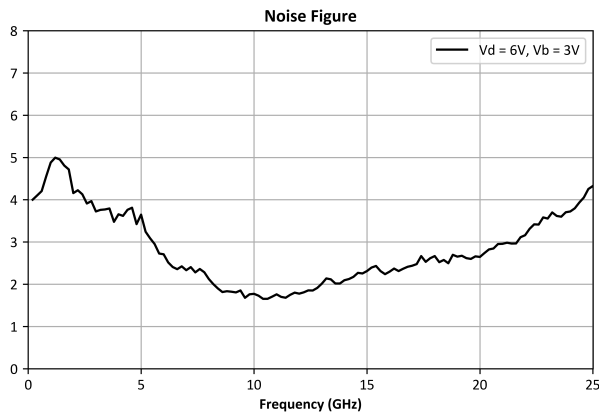
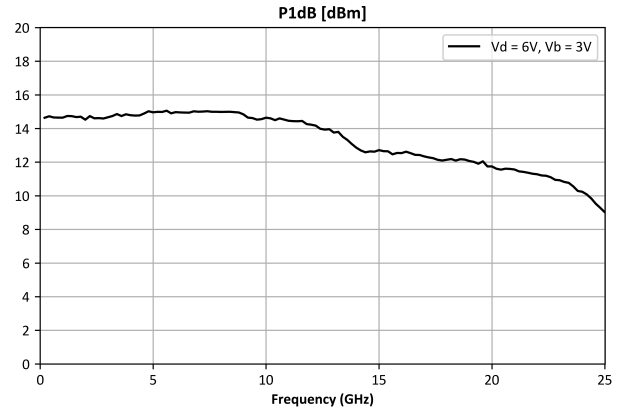
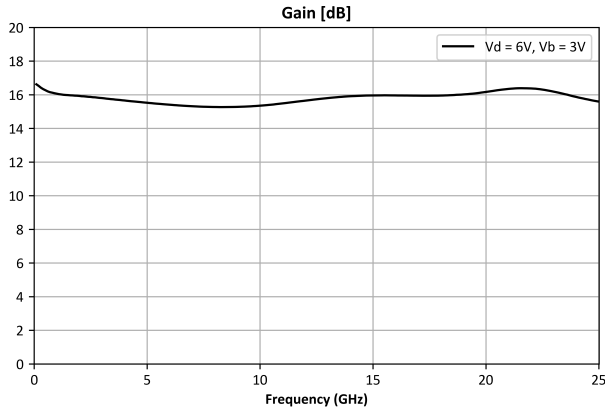

ADM-8558PC - Typical Performance Plots

Performance plots for the connectorized module are shown for measurements where directly probed measurements of the die are unavailable. Note that the following measurements include losses from connectors and microstrip traces.

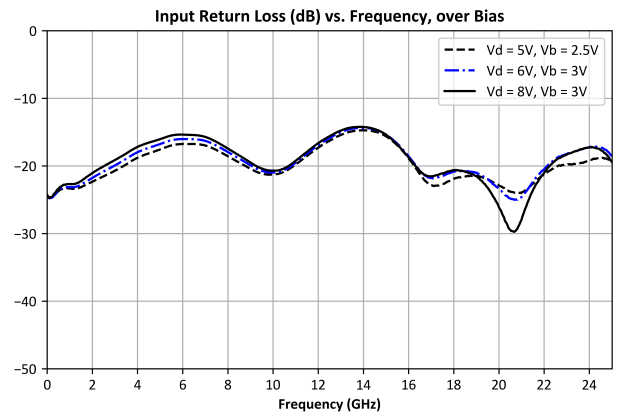
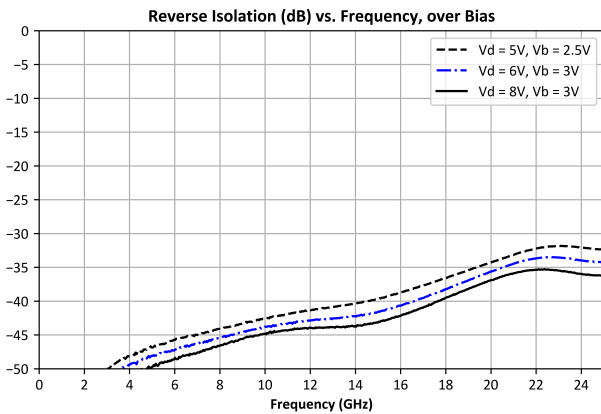
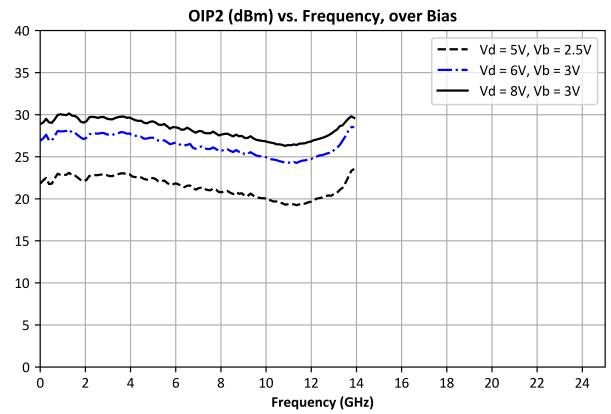
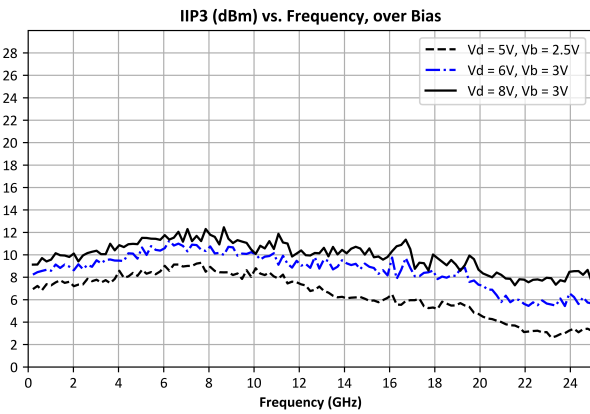
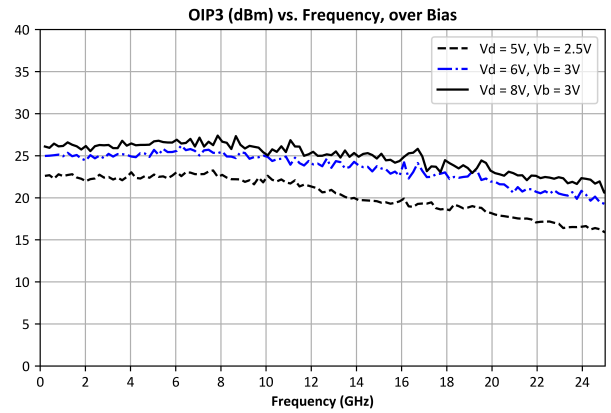
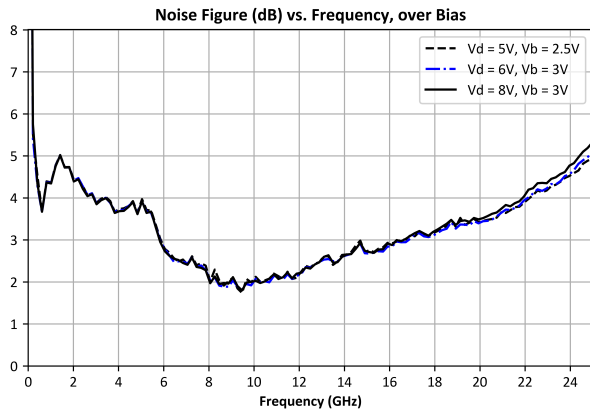
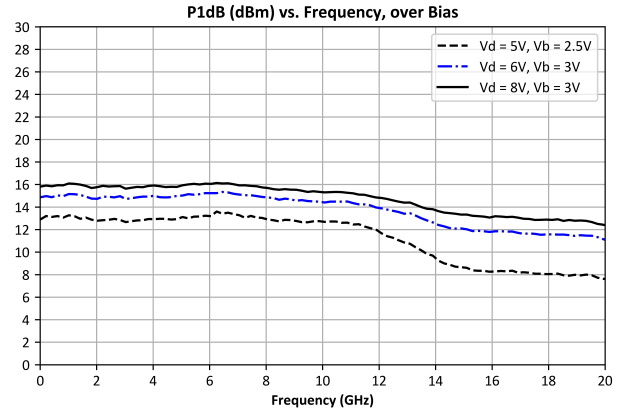
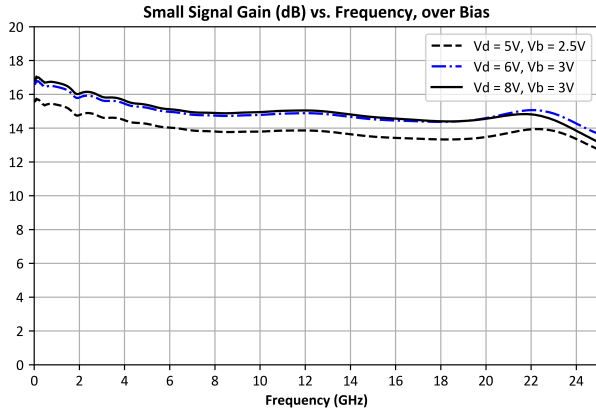

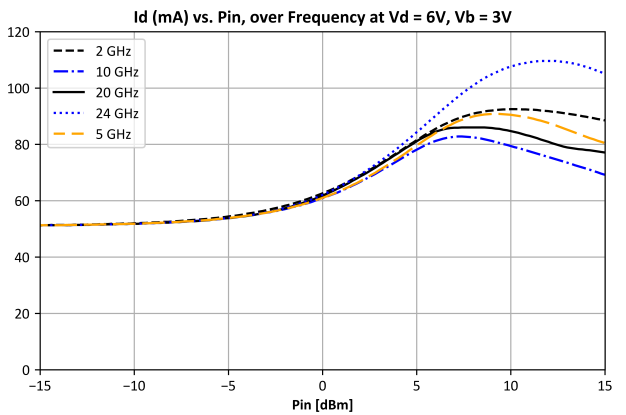
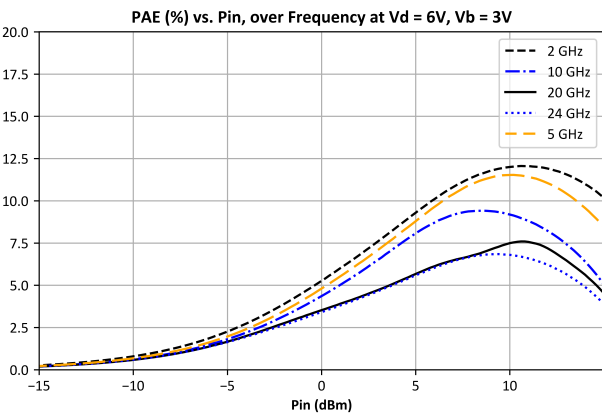
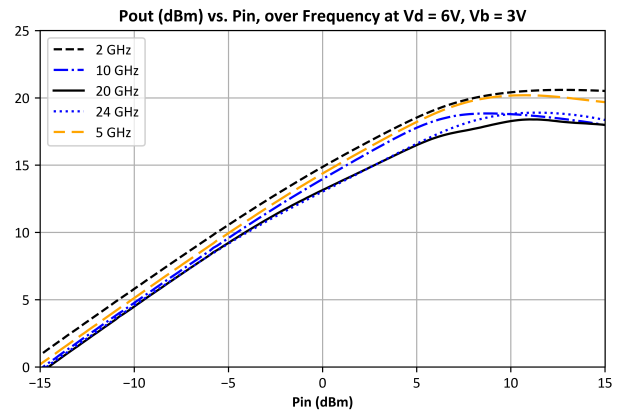
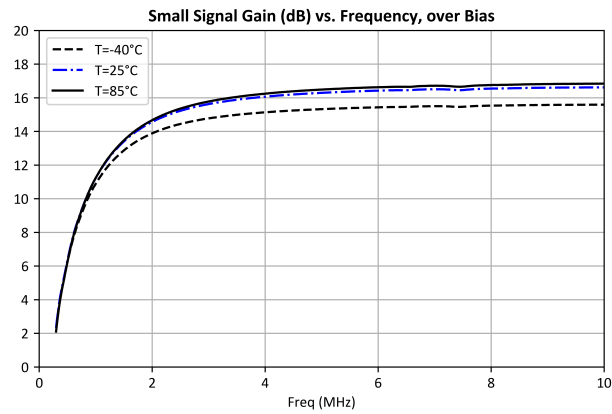
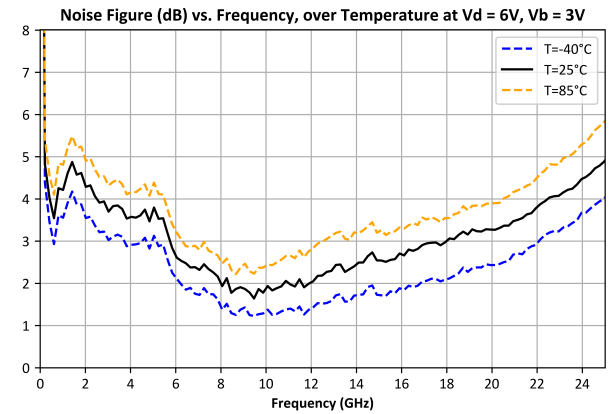
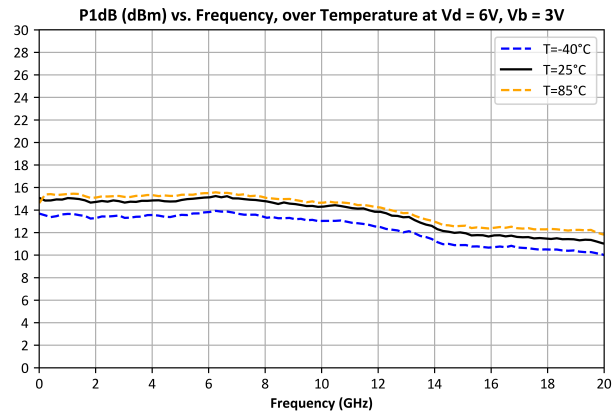
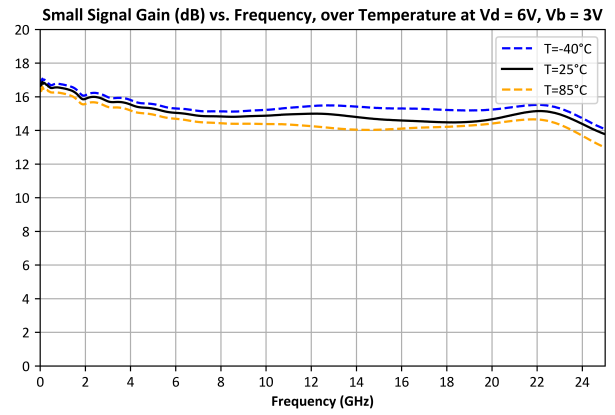
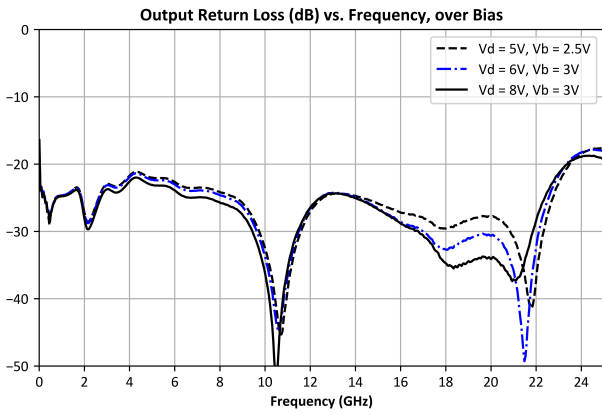

Application Information

Below is the recommended application circuit for the ADM-8558CH.

Application Circuit

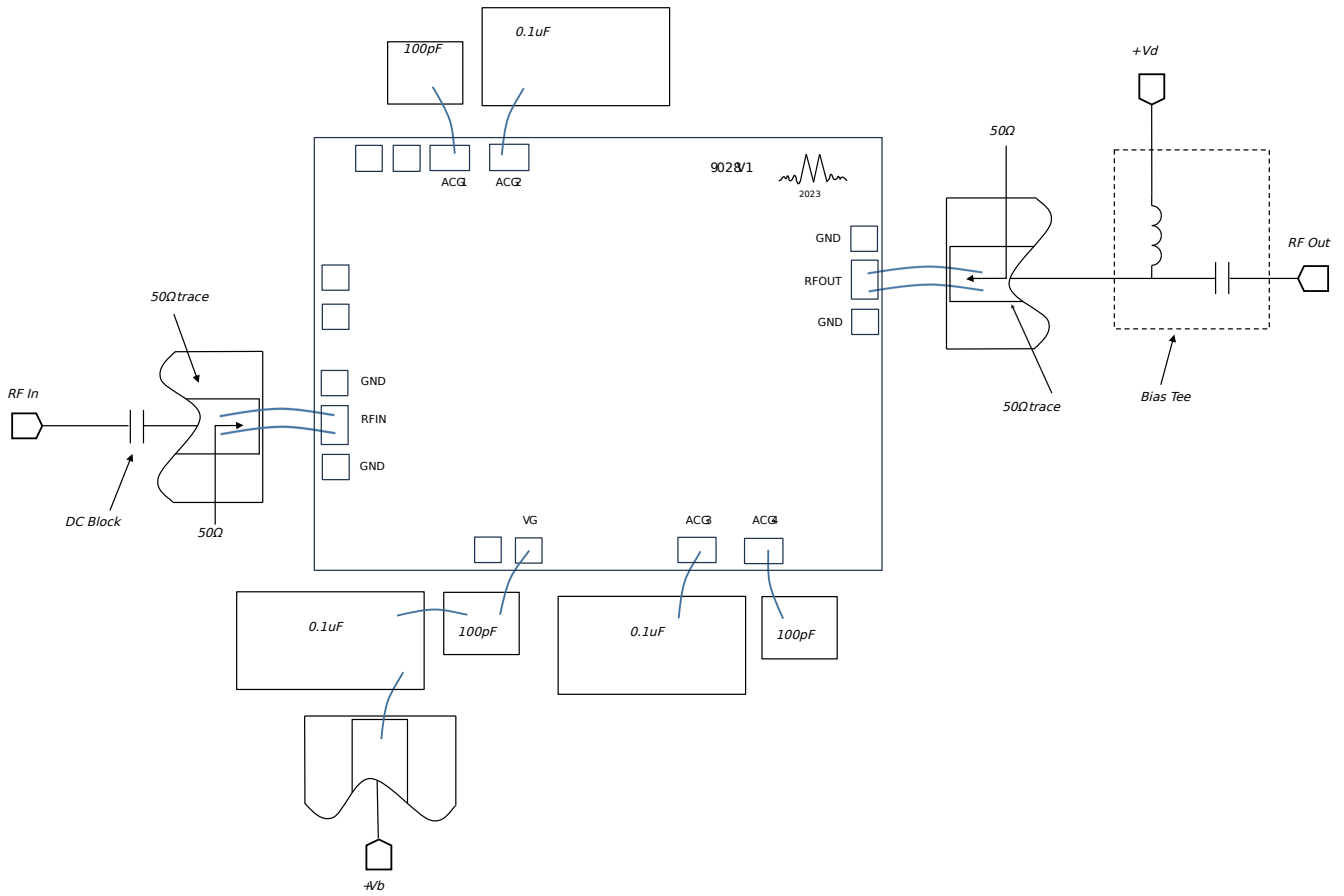

Die Mounting Recommendations

Mounting and Bonding Recommendations

Marki MMICs should be attached directly to a ground plane with conductive epoxy. The ground plane electrical impedance should be as low as practically possible. This will prevent resonances and permit the best possible electrical performance. Datasheet performance is only guaranteed in an environment with a low electrical impedance ground.

Mounting - To epoxy the chip, apply a minimum amount of conductive epoxy to the mounting surface so that a thin epoxy fillet is observed around the perimeter of the chip. Cure epoxy according to manufacturer instructions.

Wire Bonding - Ball or wedge bond with 0.025 mm (1 mil) diameter pure gold wire. Thermosonic wirebonding with a nominal stage temperature of 150 °C and a ball bonding force of 40 to 50 grams or wedge bonding force of 18 to 22 grams is recommended. Use the minimum level of ultrasonic energy to achieve reliable wirebonds. Wirebonds should be started on the chip and terminated on the package or substrate. Bond wire inductance will improve return loss. Bondwire inductance in the range of 30pH to 200pH will improve performance.

Circuit Considerations – 50 Ω transmission lines should be used for all high frequency connections in and out of the chip. Wirebonds should be kept as short as possible, with multiple wirebonds recommended for higher frequency connections to reduce parasitic inductance. In circumstances where the chip more than .001" thinner than the substrate, a heat spreading spacer tab is optional to further reduce bondwire length and parasitic inductance.

Handling Precautions

General Handling

Chips should be handled with care using tweezers or a vacuum collet. Users should take precautions to protect chips from direct human contact that can deposit contaminants, like perspiration and skin oils on any of the chip's surfaces.

Static Sensitivity

GaAs MMIC devices are sensitive to ESD and should be handled, assembled, tested, and transported only in static protected environments.

Cleaning and Storage: Do not attempt to clean the chip with a liquid cleaning system or expose the bare chips to liquid. Once the ESD sensitive bags the chips are stored in are opened, chips should be stored in a dry nitrogen atmosphere.

Mechanical Data

Outline Drawing

Download : [Outline 2D Drawing](#)

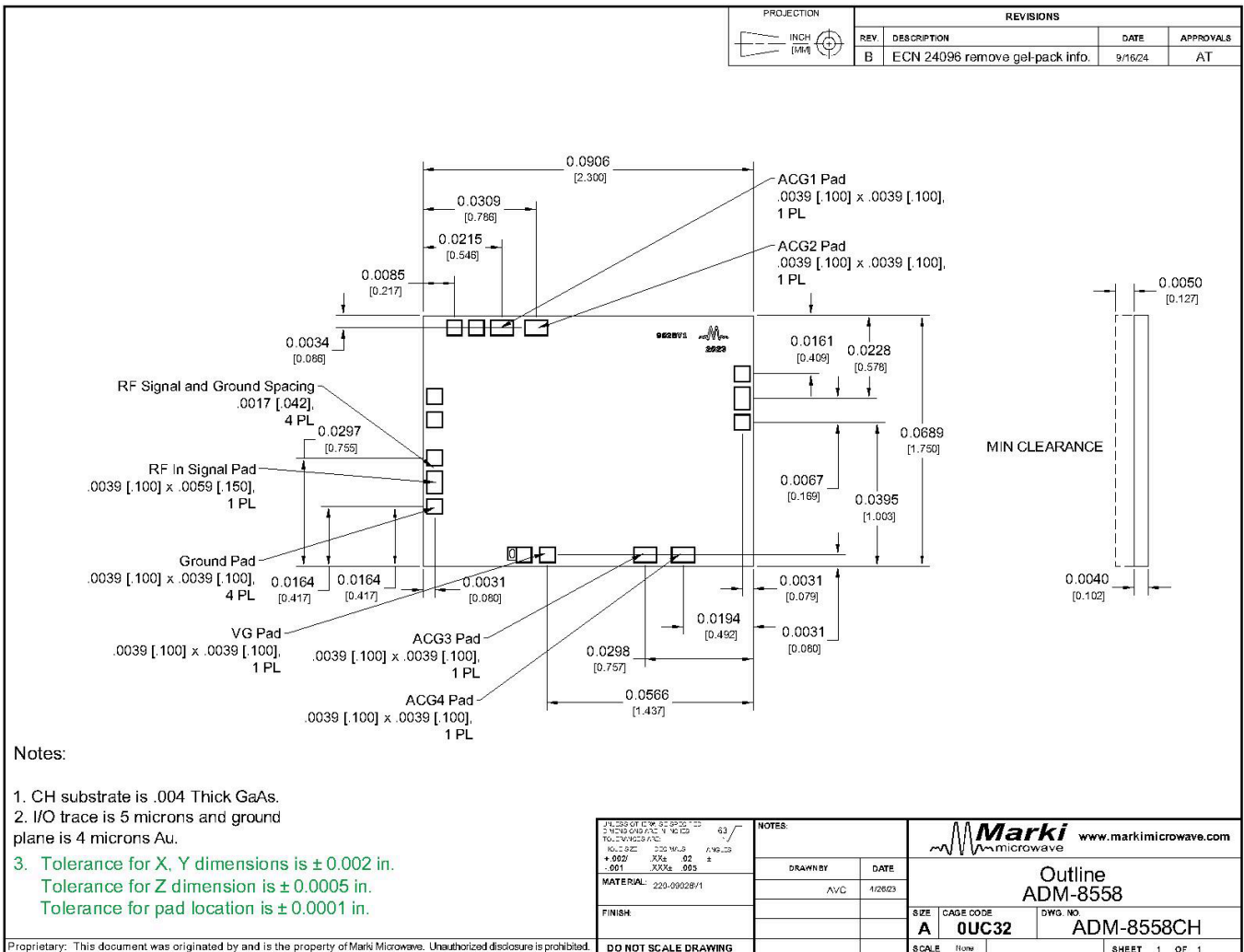

Notes:

- CH substrate is 0.004 thick GaAs.
- I/O trace is 5 microns and ground plane is 4 microns Au.
- Tolerance for X, Y dimensions is ± 0.002 in.
- Tolerance for Z dimensions is ± 0.0005 in.
- Tolerance for pad location is ± 0.0001 in.

DISCLAIMER

MARKI MICROWAVE, INC., ("MARKI") PROVIDES TECHNICAL SPECIFICATIONS AND DATA (INCLUDING DATASHEETS), APPLICATION OR OTHER DESIGN ADVICE, WEB TOOLS, AND OTHER INFORMATION AND RESOURCES "AS IS" AND WITH ALL FAULTS. MARKI DISCLAIMS ALL WARRANTIES, EXPRESS OR IMPLIED, INCLUDING, WITHOUT LIMITATION, ANY IMPLIED WARRANTIES OF MERCHANTABILITY, FITNESS FOR A PARTICULAR PURPOSE, OR NON-INFRINGEMENT.

These resources are intended for developers skilled in the art designing with Marki products. You are solely responsible for (1) selecting the appropriate products for your application, (2) designing, validating, and testing your application, and (3) ensuring your application meets applicable standards and other requirements. Marki makes no guarantee regarding the suitability of its products for any particular purpose, nor does Marki assume any liability whatsoever arising out of your use or application of any Marki product.

Marki grants you permission to use these resources only for development of an application that uses Marki products. Other reproduction or use of these resources is strictly prohibited. No license is granted to any other Marki intellectual property or to any third-party intellectual property. Marki reserves the right to make changes to the product(s) or information contained herein without notice.

MARKI MICROWAVE and T3 MIXER are trademarks or registered trademarks of Marki Microwave, Inc. All other trademarks used are the property of their respective owners.

© 2023 - 2024, Marki Microwave, Inc