

# MM1A-0222HPSM-2

## Double Balanced Mixer/LO Amplifier

### DEVICE OVERVIEW

#### General Description

The MM1A-0222HPSM is a versatile, robust, and broadband double balanced mixer with an integrated broadband LO driver amplifier. The MM1A-0222HPSM is ideal for applications with wide bandwidths and operation through the K band. The integrated LO driver amplifier allows for operation with LO powers as low as +3dBm while retaining exceptional conversion loss and linearity.

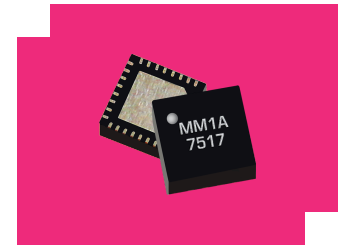

#### Features

- RF/LO response: 2GHz - 22GHz
- IF response: DC – 3.5GHz
- Conversion Loss: 7.5 dB
- Minimum LO drive: +3dBm

#### Applications

- Test and Measurement Equipment
- SATCOM
- Radar
- Low LO Drive Applications

#### Functional Block Diagram

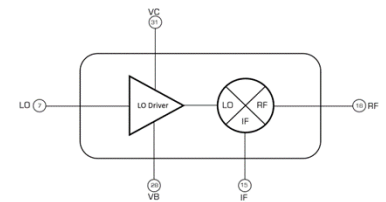

#### Part Ordering Options

Part Number	Description	Package	Green Status	Product Lifecycle	Export Classification
MM1A-0222HPSM-2	Double Balanced Mixer/LO Amplifier	QFN	REACH RoHS	Released	EAR99
EVB-MM1A-0222HP	Evaluation Board, Double Balanced Mixer/LO Amplifier	EVB	REACH RoHS	Released	EAR99

**Table Of Contents**

- **Device Overview**
  - General Description
  - Features
  - Applications
  - Functional Block Diagram
- **Port Configuration and Functions**
  - Port Diagram
  - Port Functions
- **Revision History**
- **Specifications**
  - Absolute Maximum Ratings
  - Package Information
  - Recommended Operating Conditions
  - Electrical Specifications
  - Typical Performance Plots
  - Spur Tables
- **Operation**
  - Application Circuit
  - Application Circuit Description
- **Mechanical Data**
  - Outline Drawing
- **Footprint Image**
- **Evaluation Board**
  - Evaluation Board Outline Drawing

**Revision History**

Revision Code	Revision Date	Comment
-	2022-09-01	Datasheet Initial Release

**Port Configuration and Functions**

**Port Diagram**

A top-down x-ray view of the MM1A-0222HPSM's PSM Package outline drawing is shown below. The MM1A-0222HPSM has the input and output ports given in Port Functions.

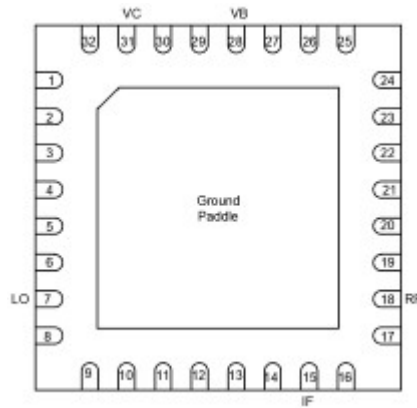

**Port Functions**

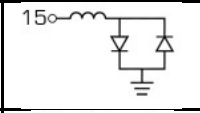
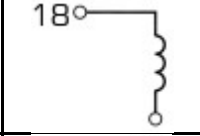
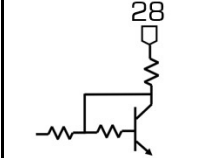
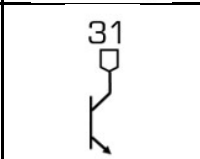
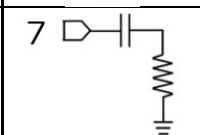
Port	Function	Description	DC Equivalent Circuit
Pin 15	IF	Pin 15 is DC coupled to the diodes. Blocking capacitor is optional.	
Pin 18	RF	Pin 18 is DC open and AC matched to 50 Ohms from 2 to 22 GHz. Blocking capacitor is optional.	
Pin 28	Vb	Port VB is the DC voltage bias for the current mirror that controls collector current supplied to the amplifier.	
Pin 31	VC	Port VC is the DC voltage supply that supplies the amplifier's collector current.	
Pin 7	LO	Pin 7 is the input of the integrated LO driver amplifier and is matched to 50 ohms. It is internally DC blocked.	

## Specifications

### Absolute Maximum Ratings

The Absolute Maximum Ratings indicate limits beyond which damage may occur to the device. If these limits are exceeded, the device may be inoperable or have a reduced lifetime. All Absolute Maximum Ratings are individual and should not be met in parallel.

Parameter	Maximum Rating	Unit
Collector Positive Bias Voltage (Vc)	6	V
Maximum Operating Temperature	85	°C
Maximum Storage Temperature	125	°C
Minimum Operating Temperature	-40	°C
Minimum Storage Temperature	-65	°C
Pin 15 DC Current (IF)	30	mA
Pin 15 RF Input Power	30	dBm
Pin 18 DC Current (RF)	30	mA
Pin 18 RF Input Power	30	dBm
Pin 7 LO Input Power	18	dBm
Positive Bias Current (Ic)	240	mA
Positive DC Current Mirror Voltage (Vb)	6	V

### Package Information

Parameter	Details	Rating
Dimensions	-	5 x 5 mm
Moisture Sensitivity Level	-	MSL 1

### Recommended Operating Conditions

The Recommended Operating Conditions indicate the limits, inside which the device should be operated, to guarantee the performance given in Electrical Specifications. Operating outside these limits may not necessarily cause damage to the device, but the performance may degrade outside the limits of the electrical specifications. For limits, above which damage may occur, see Absolute Maximum Ratings.

Parameter	Min	Nominal	Max	Unit
Ambient Temperature	-40	25	85	°C
LO Input Power	3	6	15	dBm
Positive DC Voltage (Vc or Vb)	4	5	7	V
Current Draw	-	-	225	mA

### Electrical Specifications

The electrical specifications apply at TA=+25°C in a 50Ω system. Typical data shown is for a down conversion application with a +6dBm LO input to the integrated LO driver amp biased at +5Vb/+5Vb unless otherwise specified.

Parameter	Test Conditions	Min	Typ	Max	Unit
Conversion Loss <sup>1</sup>	RF/LO = 2 - 22 GHz I = 0.2 - 3.5 GHz	-	9.5	13	dB
Conversion Loss <sup>2</sup>	RF/LO = 2 - 22 GHz I = DC - 0.2 GHz	-	7.5	-	dB
Current Consumption	+6.0VB/+7.0VC	-	105	-	mA
IF Frequency Range	-	0	-	3.5	GHz
Input IP3	RF/LO = 2 - 22 GHz I = DC - 0.2 GHz	-	17	-	dBm
Input P1dB	-	-	9	-	dBm
LO Frequency Range	-	2	-	22	GHz
Noise Figure <sup>3</sup>	RF/LO = 1.5 - 13 GHz I = DC - 0.2 GHz	-	7.5	-	dB
RF Frequency Range	-	2	-	22	GHz
RF-IF Isolation	RF/LO = 2 - 22 GHz	-	36	-	dB

[1][2] Measured as a down converter to a fixed 91 MHz IF.

[3] Mixer Noise Figure typically measures within 0.5 dB of conversion loss for IF frequencies greater than 5 MHz.

**Typical Performance Plots**

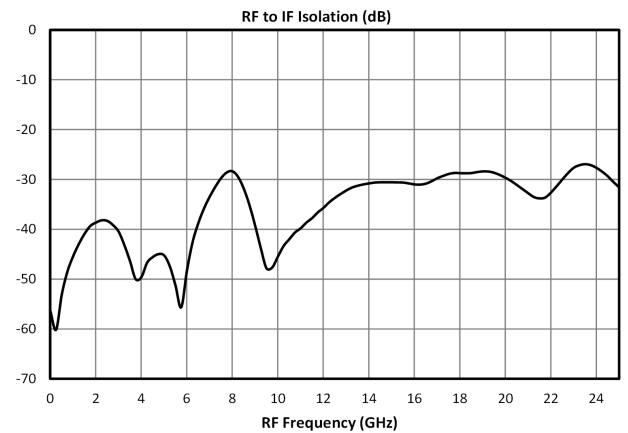
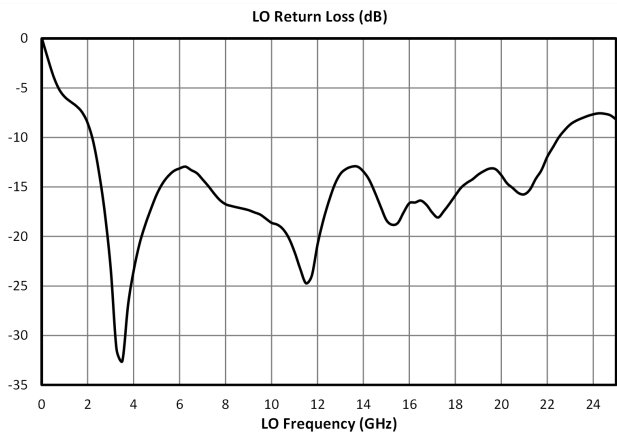
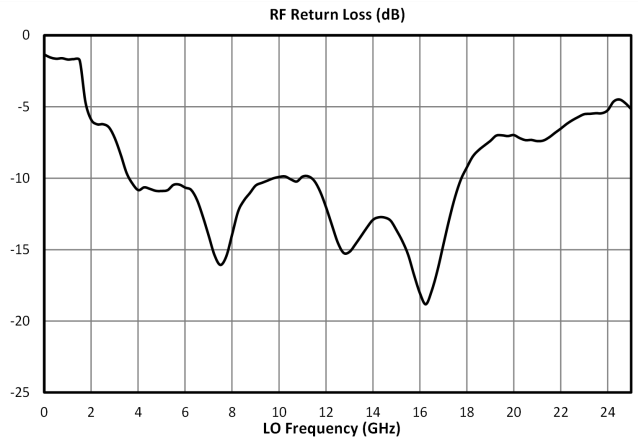
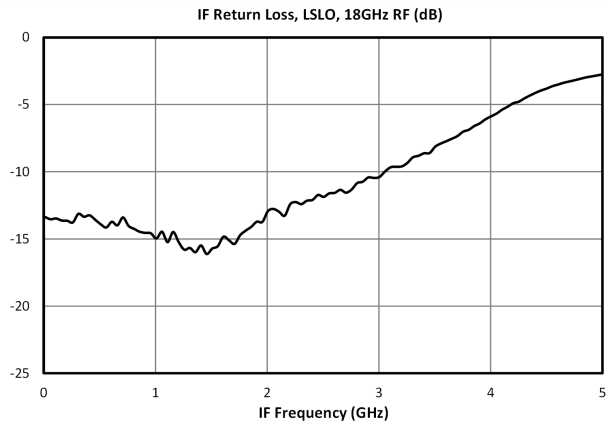
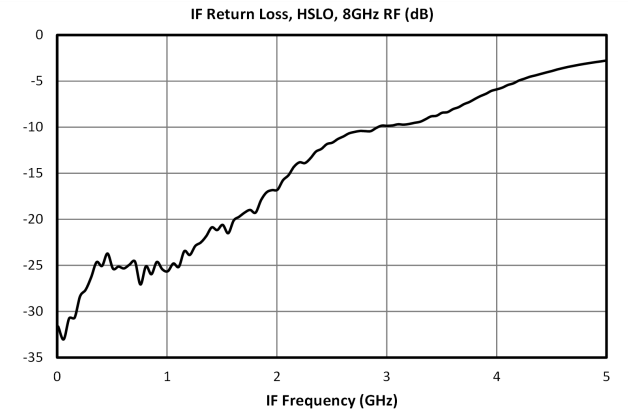
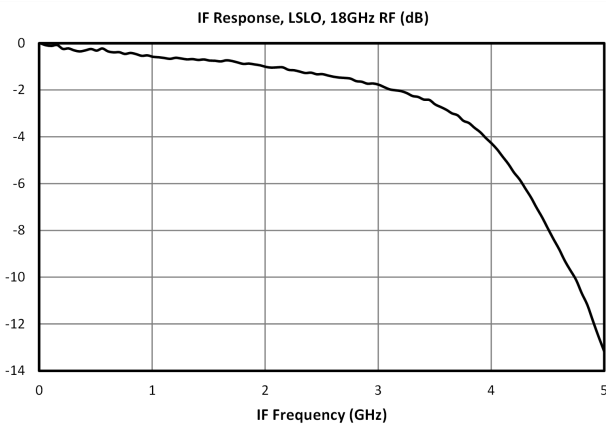
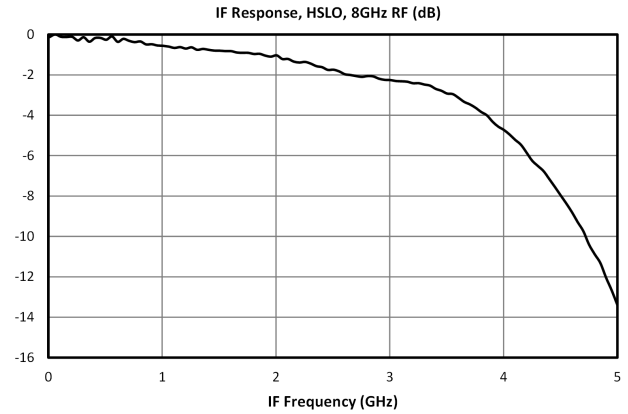
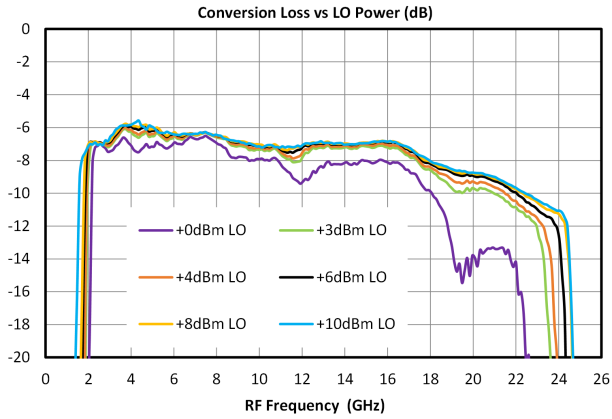

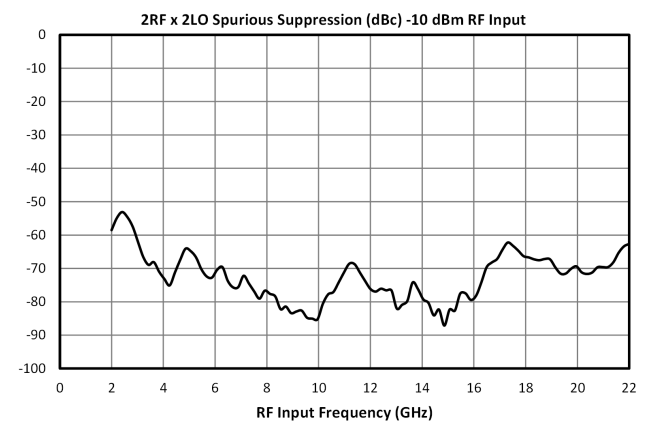
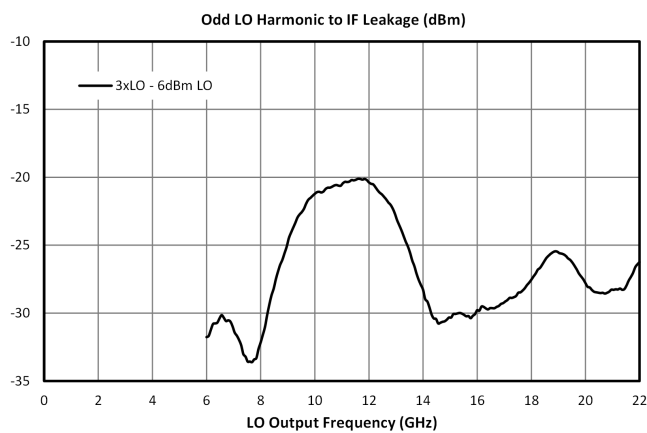
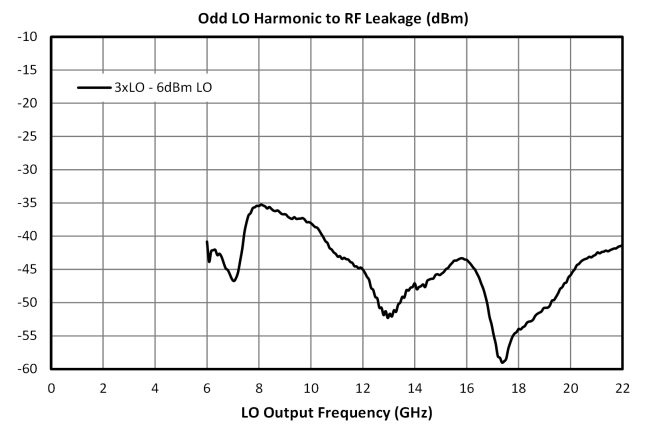
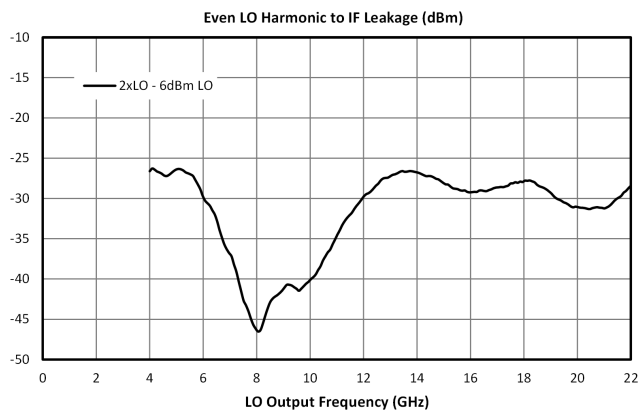
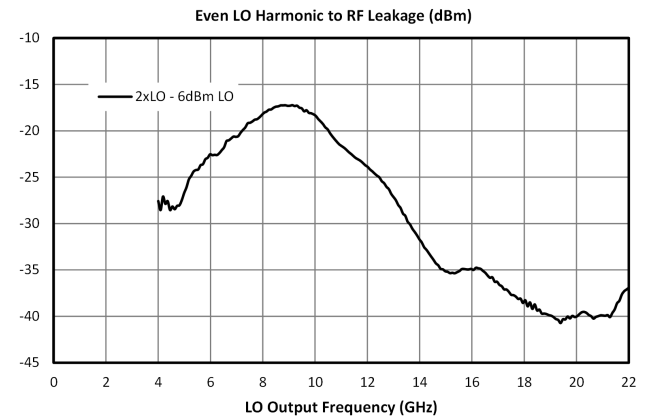
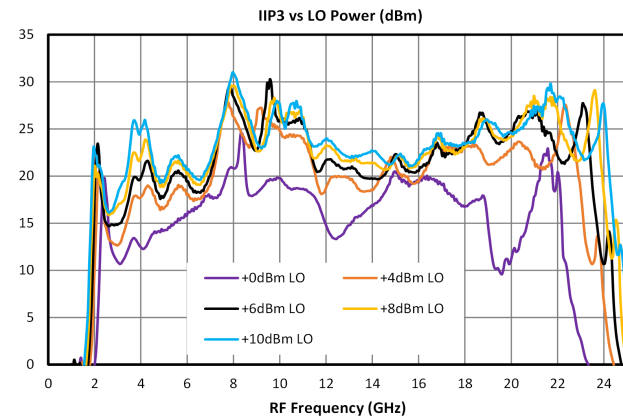
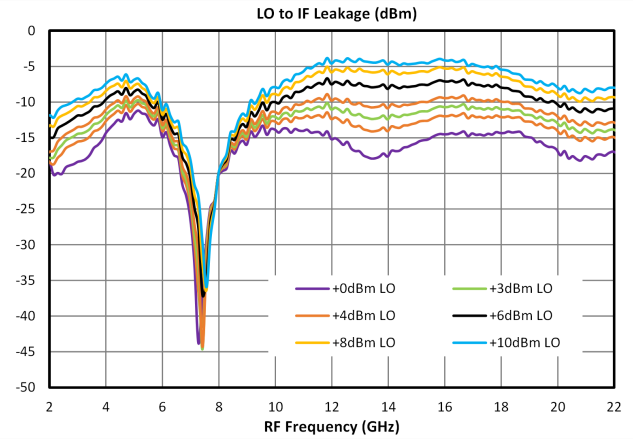
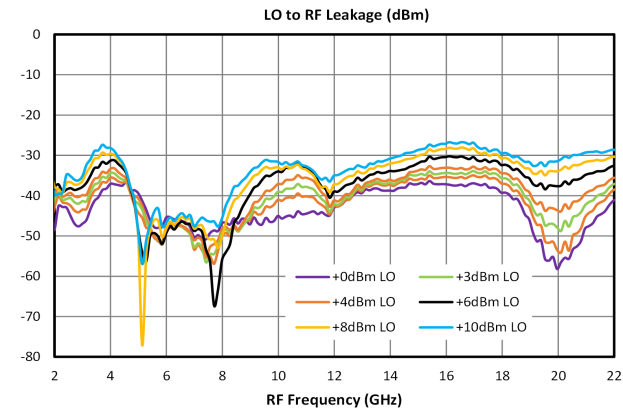

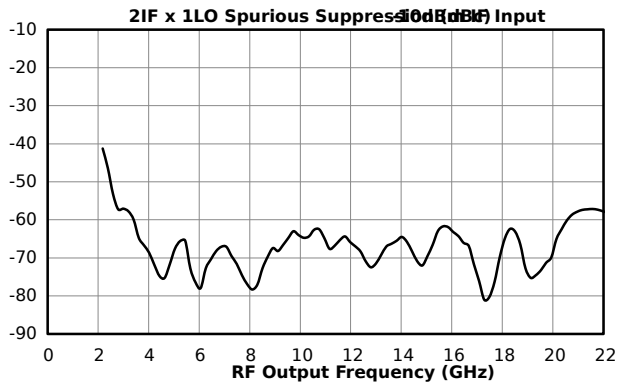

**Spur Table**

**Typical Spurious Performance: Down-Conversion**

Typical spurious data is provided by selecting RF and LO frequencies ( $\pm m*LO \pm n*RF$ ) within the RF/LO bands, to create a spurious output within the IF band. The mixer is swept across the full spurious band and the mean is calculated. The numbers shown in the table below are for a -10 dBm RF input. Spurious suppression is scaled for different RF power levels by (n-1), where “n” is the RF spur order. For example, the 2RF x 2LO spur is 60 dBc for a -10 dBm input, so a -20 dBm RF input creates a spur that is (2-1) x (-10 dB) lower, or 70 dBc. Data is shown for the frequency plan in 3.6 Typical Performance. mLOx0RF plots can be found in section 3.6.2.

**Typical Down-conversion spurious suppression (dBc)**

-10 dBm RF Input	0xLO	1xLO	2xLO	3xLO	4xLO	5xLO
1xRF	25	Reference	25	10	28	N/A
2xRF	72	60	60	74	66	72
3xRF	84	63	62	78	77	79
4xRF	N/A	N/A	67	107	112	111
5xRF	N/A	N/A	107	108	118	125

**Typical Spurious Performance: Up-Conversion**

Typical spurious data is taken by mixing an input within the IF band, with LO frequencies ( $\pm m \cdot LO \pm n \cdot IF$ ), to create a spurious output within the RF output band. The mixer is swept across the full spurious output band and the mean is calculated. The numbers shown in the table below are for a -10 dBm IF input. Spurious suppression is scaled for different IF input power levels by (n-1), where “n” is the IF spur order. For example, the 2IFx1LO spur is typically 66 dBc for a -10 dBm input with a sine-wave LO, so a -20 dBm IF input creates a spur that is (2-1) x (-10 dB) lower, or 76 dBc. Data is shown for the frequency plan in 3.6 Typical Performance.

**Typical Up-conversion spurious suppression (dBc)**

-10 dBm IF Input	0xLO	1xLO	2xLO	3xLO	4xLO	5xLO
1xIF	21	Reference	24	10	45	17
2xIF	50	66	65	67	59	62
3xIF	82	71	76	64	74	66
4xIF	102	109	105	105	96	98
5xIF	134	120	125	114	123	110

**Application Circuit**

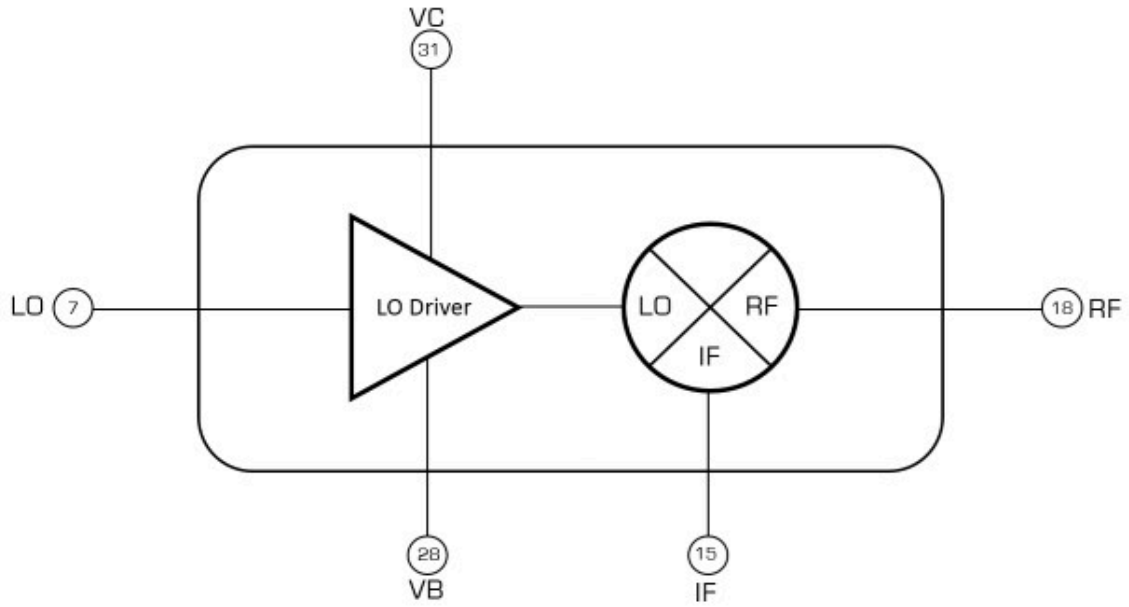

## Application Circuit Description

### Ports Operation

**IF Port** – Used as input on an upconversion, output on downconversion, or LO port in a band shifting application. Signals should be connected by 50 ohm microstrip or coplanar traces to well matched broadband 50 ohm sources and loads.

**RF Port** – Used as input on a downconversion, output on upconversion, or output in a band shifting application. Signals should be connected by 50 ohm microstrip or coplanar traces to well matched broadband 50 ohm sources and loads.

**LO Port** – The noise floor of the LO input signal should be less than the value of the noise floor plus isolation of the mixer, or a filter is recommended to prevent reduction in dynamic range. An integrated LO amplifier is included, allowing for superior performance with LO power below the typical recommended drive level.

**Filtering and Matching**- Filtering is generally desired for spurious and image removal on the output port of the mixer. Reflective filters can cause out of band signals to reflect back into the mixer and cause conversion loss ripple, erroneous spurs, and other undesired behaviors. To eliminate these problems it is recommended that the filters be placed as close to the output port as possible. If undesired behavior is still observed, a diplexer with one port terminated or a 1-3 dB attenuator may reduce this problem.

**RF Ground** – The ground paddle of the QFN should be connected to a low noise RF ground with very low electrical resistance for high frequency operation.

**Mechanical Data**

**Outline Drawing**

Download : [Outline 2D Drawing](#) | [Outline 3D Drawing](#) | [Outline 3D STP](#)

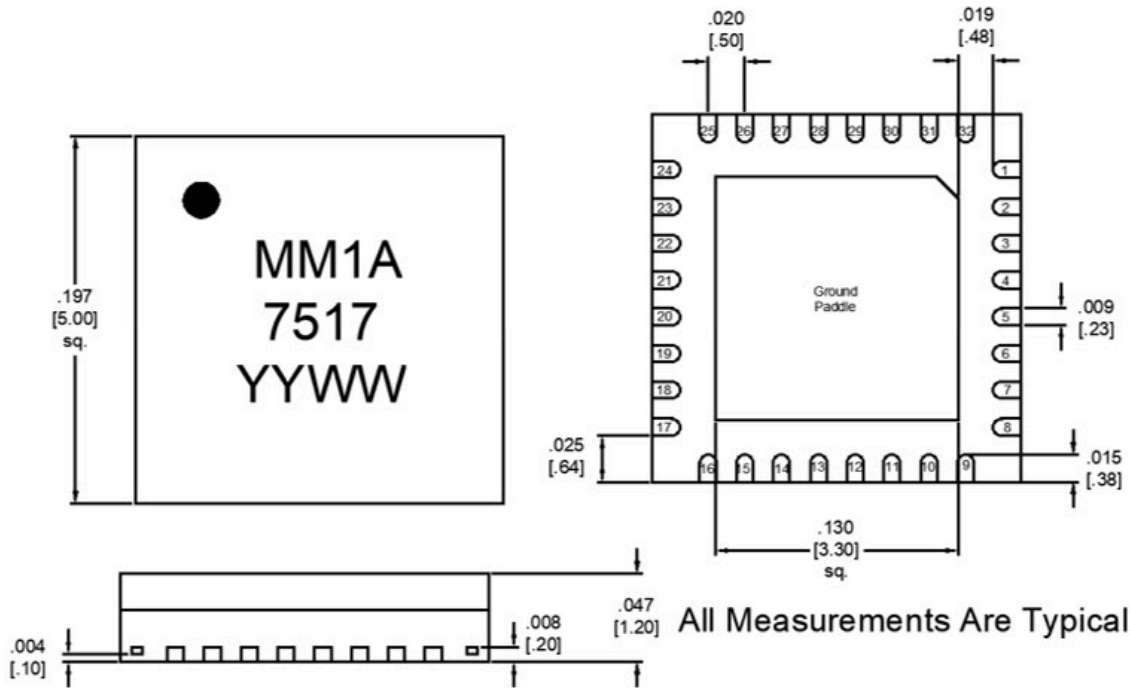

All Measurements Are Typical

Pin #	Function
1	N/C
2	N/C
3	N/C
4	N/C
5	N/C
6	N/C
7	LO
8	N/C
9	N/C
10	N/C
11	N/C
12	N/C
13	N/C
14	N/C
15	IF
16	N/C
17	N/C
18	RF
19	N/C
20	N/C
21	N/C
22	N/C
23	N/C
24	N/C
25	N/C
26	N/C
27	N/C
28	VB
29	N/C
30	N/C
31	VC
32	N/C

- Substrate material is LCP.
- I/O Leads and Die Paddle are: 0.003 microns Gold (MIN)  
 0.08 - 0.15 microns Palladium  
 0.5 - 2.0 microns Nickel.
- All unconnected pins should be connected to PCB RF ground.

**Footprint Image**

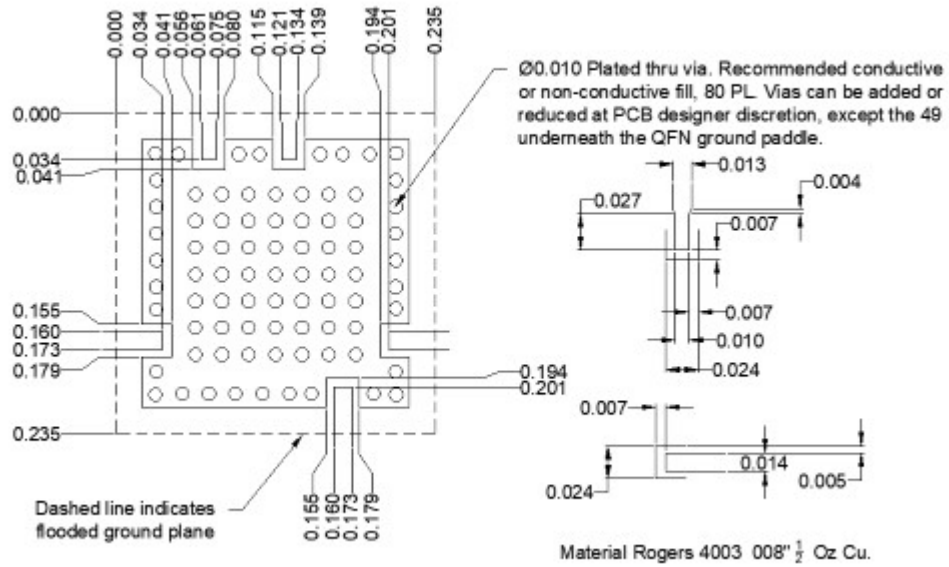

**Evaluation Board - Outline Drawing**

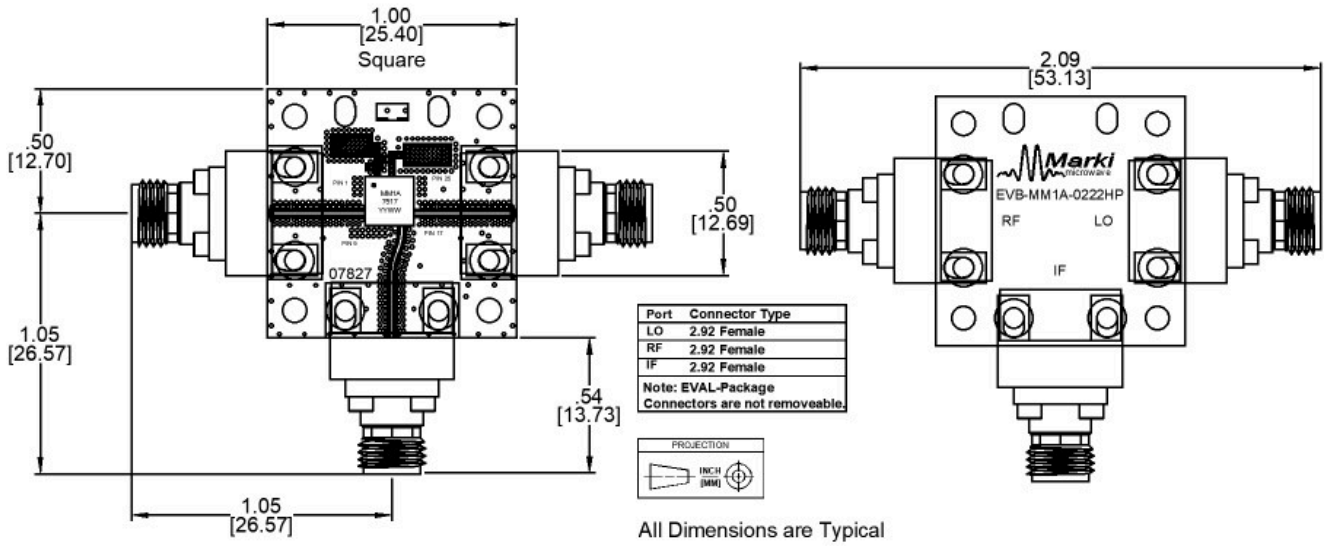

**DISCLAIMER**

MARKI MICROWAVE, LLC., ("MARKI") PROVIDES TECHNICAL SPECIFICATIONS AND DATA (INCLUDING DATASHEETS), APPLICATION OR OTHER DESIGN ADVICE, WEB TOOLS, AND OTHER INFORMATION AND RESOURCES "AS IS" AND WITH ALL FAULTS. MARKI DISCLAIMS ALL WARRANTIES, EXPRESS OR IMPLIED, INCLUDING, WITHOUT LIMITATION, ANY IMPLIED WARRANTIES OF MERCHANTABILITY, FITNESS FOR A PARTICULAR PURPOSE, OR NON-INFRINGEMENT.

These resources are intended for developers skilled in the art designing with Marki products. You are solely responsible for (1) selecting the appropriate products for your application, (2) designing, validating, and testing your application, and (3) ensuring your application meets applicable standards and other requirements. Marki makes no guarantee regarding the suitability of its products for any particular purpose, nor does Marki assume any liability whatsoever arising out of your use or application of any Marki product.

Marki grants you permission to use these resources only for development of an application that uses Marki products. Other reproduction or use of these resources is strictly prohibited. No license is granted to any other Marki intellectual property or to any third-party intellectual property. Marki reserves the right to make changes to the product(s) or information contained herein without notice.

MARKI MICROWAVE and T3 MIXER are trademarks or registered trademarks of Marki Microwave, LLC. All other trademarks used are the property of their respective owners.

© 2022, Marki Microwave, LLC