

# MQH-40110M2

## MMIC 40-110GHz Quadrature Hybrid

### DEVICE OVERVIEW

#### General Description

The MQH-40110M2 is a 40–110 GHz quadrature (90°) hybrid in our miniature M2-package enabling operation up to 110 GHz. The quad hybrid features exceptional amplitude and phase balance and high isolation between the quadrature ports. Passive GaAs MMIC technology allows production of smaller constructions that replace larger form factor circuit board constructions. Tight fabrication tolerances allow for less unit-to-unit variation than traditional quadrature hybrid technologies. Low variation allows for accurate simulations using the provided S4P file taken from measured production units. The MQH-40110M2 is available as a 1.0mm connectorized module.

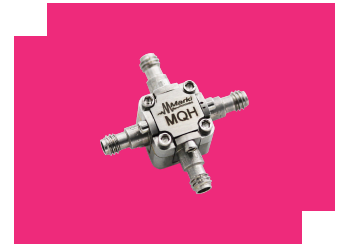

#### Features

- Designed for V/W-band applications
- Excellent amplitude and phase balance
- High isolation
- Low insertion loss

#### Applications

- Single Sideband Upconverters
- Image Rejection Downconverters
- IQ Modulators
- Balanced Amplifiers
- mmWave Correlators
- mmWave Butler Matrices

#### Functional Block Diagram

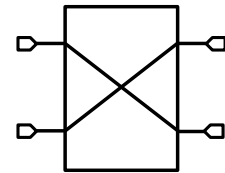

#### Part Ordering Options

Part Number	Description	Package	Connectors	Green Status	Product Lifecycle	Export Classification
MQH-40110M2	MMIC 40-110GHz Quadrature Hybrid	M2	<u>Standard</u>	REACH RoHS	Released	EAR99

## Table Of Contents

- **Device Overview**
  - General Description
  - Features
  - Applications
  - Functional Block Diagram
- **Port Configuration and Functions**
  - Port Diagram
  - Port Functions
- **Specifications**
  - Absolute Maximum Ratings
  - Package Information
  - Electrical Specifications
  - Typical Performance Plots
- **Operation**
  - Application Information
- **Mechanical Data**
  - Outline Drawing

## Port Configuration and Functions

### Port Diagram

A top-down view of the MQH-40110M2 package outline drawing is shown below. This MMIC quadrature hybrid is a passive reciprocal device allowing any port to be used as the input. Ports 1 – 4 correspond to the M2 package designation.

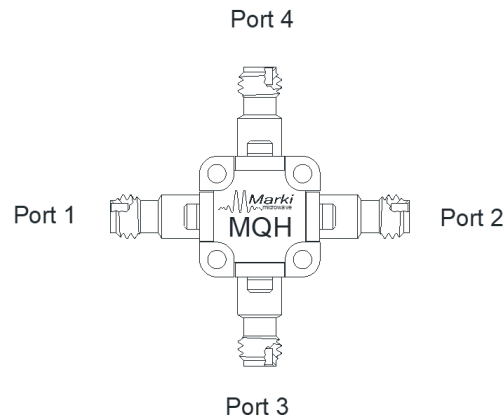

## Port Functions

### Configuration A

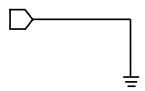
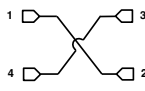
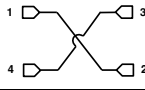
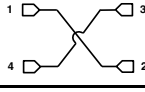
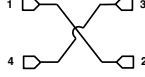
Port	Function	Connector Type	Description	Equivalent Circuit for Package
GND	Ground	-	M2 package ground path is provided through the metal housing.	
Port 1	Input/Output	1.0F	Port 1 is DC short to port 2 and open to ground.	
Port 2	0° Output/Input	1.0F	Port 2 is DC short to port 1 and open to ground.	
Port 3	90° Output/Input	1.0F	Port 3 is DC short to port 4 and open to ground.	
Port 4	Isolated	1.0F	Port 4 is DC short to port 3 and open to ground.	

**Configuration B**

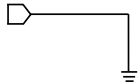
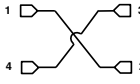
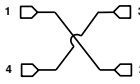
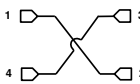
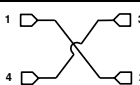
Port	Function	Connector Type	Description	Equivalent Circuit for Package
GND	Ground	-	M2 package ground path is provided through the metal housing.	
Port 1	0° Output/Input	1.0F	Port 1 is DC short to port 2 and open to ground.	
Port 2	Input/Output	1.0F	Port 2 is DC short to port 1 and open to ground.	
Port 3	Isolated	1.0F	Port 3 is DC short to port 4 and open to ground.	
Port 4	90° Output/Input	1.0F	Port 4 is DC short to port 3 and open to ground.	

**Configuration C**

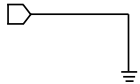
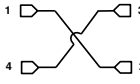
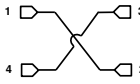
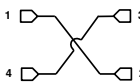
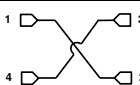
Port	Function	Connector Type	Description	Equivalent Circuit for Package
GND	Ground	-	M2 package ground path is provided through the metal housing.	
Port 1	90° Output/Input	1.0F	Port 1 is DC short to port 2 and open to ground.	
Port 2	Isolated	1.0F	Port 2 is DC short to port 1 and open to ground.	
Port 3	Input/Output	1.0F	Port 3 is DC short to port 4 and open to ground.	
Port 4	0° Output/Input	1.0F	Port 4 is DC short to port 3 and open to ground.	

**Configuration D**

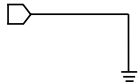
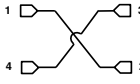
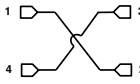
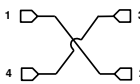
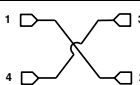
Port	Function	Connector Type	Description	Equivalent Circuit for Package
GND	Ground	-	M2 package ground path is provided through the metal housing.	
Port 1	Isolated	1.0F	Port 1 is DC short to port 2 and open to ground.	
Port 2	90° Output/Input	1.0F	Port 2 is DC short to port 1 and open to ground.	
Port 3	0° Output/Input	1.0F	Port 3 is DC short to port 4 and open to ground.	
Port 4	Input/Output	1.0F	Port 4 is DC short to port 3 and open to ground.	

## Specifications

### Absolute Maximum Ratings

The Absolute Maximum Ratings indicate limits beyond which damage may occur to the device. If these limits are exceeded, the device may be inoperable or have a reduced lifetime.

Parameter	Maximum Rating	Unit
DC Current, at any Port	48	mA
Maximum Operating Temperature	100	°C
Maximum Storage Temperature	125	°C
Minimum Operating Temperature	-55	°C
Minimum Storage Temperature	-65	°C
Power Handling, at any Port	1	W

### Package Information

Parameter	Details	Rating
ESD	250 to < 500 Volts	HBM Class 1A
Dimensions	-	27.62 x 27.63 mm

**Electrical Specifications**

The electrical specifications apply at TA=+25°C in a 50Ω system. Min and Max limits are guaranteed at TA=+25°C.

Parameter	Port Configuration	Test Conditions	Minimum Frequency (GHz)	Maximum Frequency (GHz)	Min	Typ	Max	Unit
Amplitude Balance	-	-	40	110	-	1	3	dB
Excess Through Line Insertion Loss	-	-	40	110	-	2.5	5	dB
Impedance	-	-	40	110	-	50	-	Ω
Isolation	-	-	40	110	-	18	-	dB
Mean Coupling	-	-	40	110	-	3	-	dB
Normal Phase Shift	-	-	40	110	-	90	-	°
Phase Balance	-	-	40	110	-	5	15	°
Return Loss	-	-	40	110	-	13	-	dB

**Typical Performance Plots**

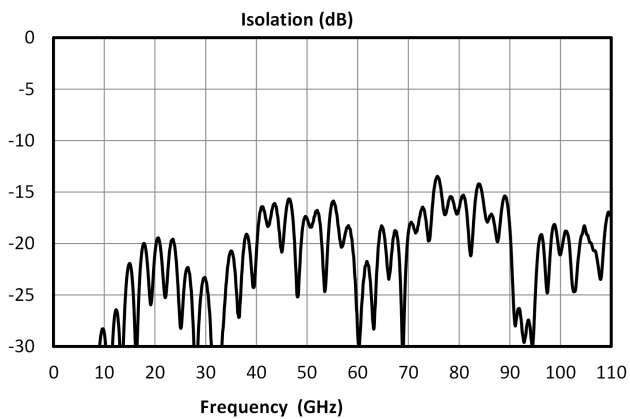
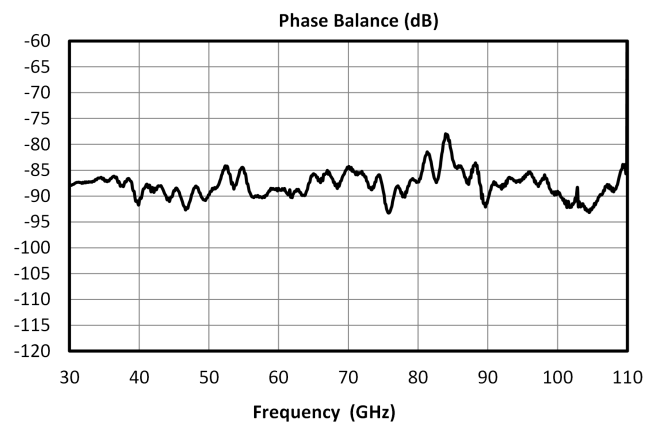
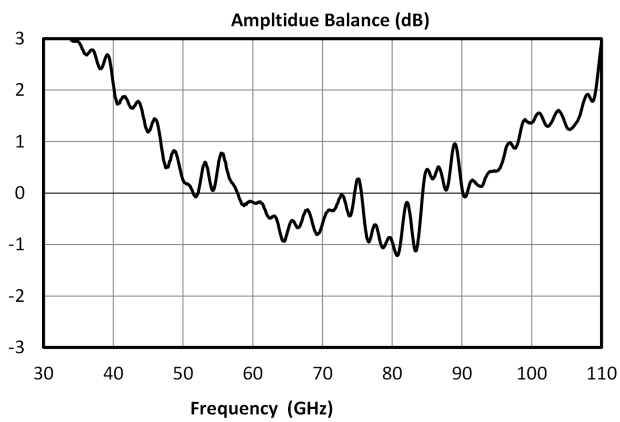
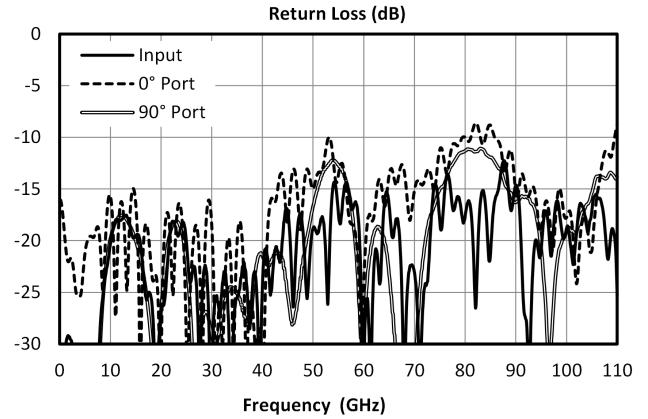
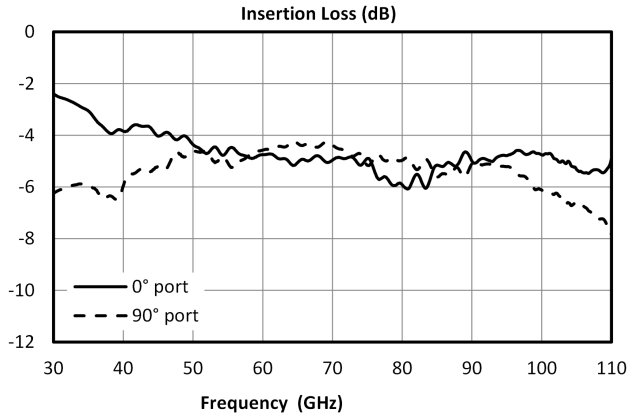

### **Application Information**

Quadrature signal generation is useful for many applications in analog signal processing. Marki MQH/S MMIC quadrature hybrids and 90° Splitter/Combiners offer this functionality in a small factor with high repeatability. Below are applications and how they can be realized with the MQH and MQS product lines.

### Quadrature Hybrids vs 90° Splitter/Combiners

Some products are 'true' quadrature hybrids, while others are 90° Splitter/Combiners. A quadrature hybrid is symmetric about all four ports, meaning that in a splitting application any port can be used as an input, with the isolated and output ports following from this selection. Likewise, for a combining application, any port can be used as an output.

A 90° Splitter/Combiner is not symmetric. When splitting, only ports 1 and 2 can be used as an input. If ports 3 or 4 were used, there would be significant phase walk-off between the output ports. As a combiner, only ports 1 and 2 are suitable as output ports. The phase walk-off introduced when using ports 3 or 4 as an output means that reflected signals recombine and cancel poorly inside a 90° Splitter/Combiner.

Single Sideband and Image Reject Mixers

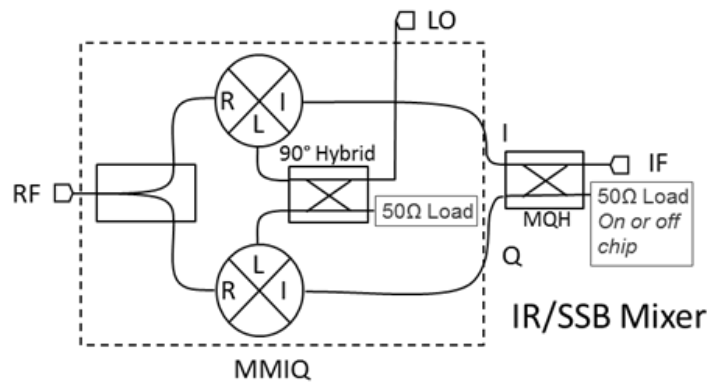

The primary application for the MQH and MQS series is as IF or LO quadrature signal splitter/combiners. They can be used in combination with the MMIQ series of IQ mixers to create broadband single sideband and image reject mixers. Either 90° Splitter/Combiners or quadrature hybrids can be used as the IF hybrid, but if a 90° Splitter/Combiner is used only one sideband (or image) is accessible, whereas if a quadrature hybrid is used than both sidebands are accessible.

If a 90° Splitter/Combiner is used for a single sideband upconverter or image reject mixer, port 1 (or 2) should be used as the IF input/output and ports 2 and 3 (or 1 and 4) should be connected to the I and Q ports. Selecting port 1 or 2 to terminate will select which sideband of the mixer to reject.

### Balanced Amplifiers

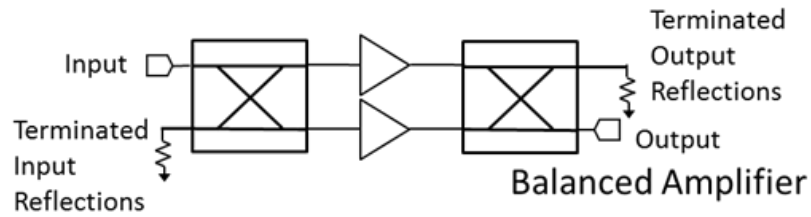

Similar to a balanced amplifier, a reflectionless filter will terminate reflections that are out of band for a filter (but in band for the quadrature hybrid) at the isolated port.

Since a 90° Splitter/Combiner is not completely symmetric, reflected signals will not terminate as well as with a quadrature hybrid. An MQH option is recommended for this application. Testing/simulation is recommended when considering if a 90° Splitter/Combiner is suitable.

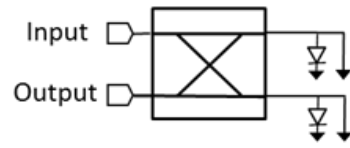

**Reflective Phase Shifter**

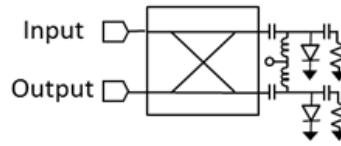

**Reflective Attenuator**

**Mechanical Data**

**Outline Drawing**

Download : [Outline 3D Drawing](#) | [Outline 3D STP](#)

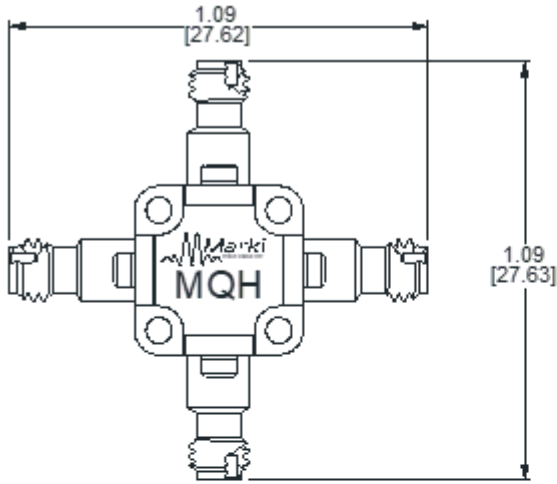

Topside View

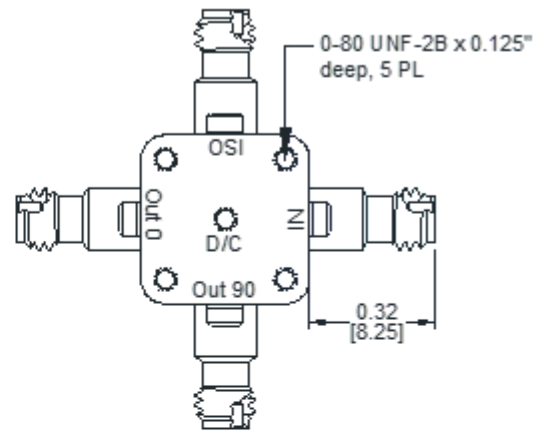

Bottomside View

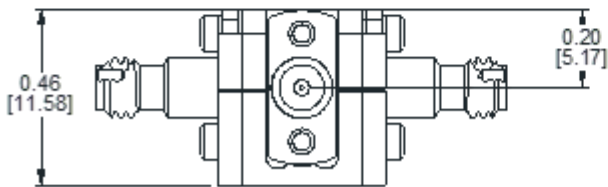

1.00 mm Connector View

All measurements are typical



Note: Connectors are not removable. Do not attempt replacing.

Port	Connector Type
1,2,3,4	1.00 mm Female

#### **DISCLAIMER**

MARKI MICROWAVE, INC., ("MARKI") PROVIDES TECHNICAL SPECIFICATIONS AND DATA (INCLUDING DATASHEETS), APPLICATION OR OTHER DESIGN ADVICE, WEB TOOLS, AND OTHER INFORMATION AND RESOURCES "AS IS" AND WITH ALL FAULTS. MARKI DISCLAIMS ALL WARRANTIES, EXPRESS OR IMPLIED, INCLUDING, WITHOUT LIMITATION, ANY IMPLIED WARRANTIES OF MERCHANTABILITY, FITNESS FOR A PARTICULAR PURPOSE, OR NON-INFRINGEMENT. These resources are intended for developers skilled in the art designing with Marki products. You are solely responsible for (1) selecting the appropriate products for your application, (2) designing, validating, and testing your application, and (3) ensuring your application meets applicable standards and other requirements. Marki makes no guarantee regarding the suitability of its products for any particular purpose, nor does Marki assume any liability whatsoever arising out of your use or application of any Marki product.

Marki grants you permission to use these resources only for development of an application that uses Marki products. Other reproduction or use of these resources is strictly prohibited. No license is granted to any other Marki intellectual property or to any third-party intellectual property. Marki reserves the right to make changes to the product(s) or information contained herein without notice.

MARKI MICROWAVE and T3 MIXER are trademarks or registered trademarks of Marki Microwave, Inc. All other trademarks used are the property of their respective owners.

© 2023 - 2025, Marki Microwave, Inc