

# AMM-7210UC

## 22 GHz – 57 GHz GaAs Driver Amplifier

### DEVICE OVERVIEW

#### General Description

The AMM-7210 is a general-purpose broadband MMIC driver amplifier that provides +21 dBm output power suitable for driving a Marki H or L diode mixer at 22-57 GHz and S diode mixer from 25-50 GHz. The small die size allows it to be used in a variety of applications, and has built in DC-blocking capacitors on the input and output.

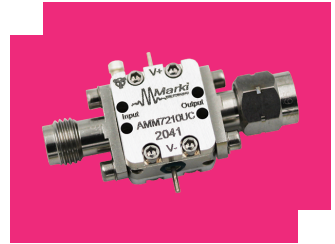

[Download s-parameters here](#)

#### Features

- +21 dBm Output Power
- Broadband Performance
- Small Die size

#### Applications

- Mobile test and measurement equipment
- 5G transceivers
- Driver amplifier L,H,S – diode mixers
- Radar
- SATCOM

#### Functional Block Diagram

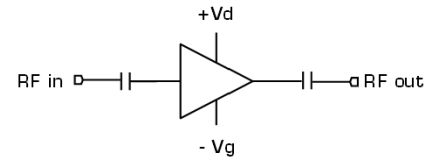

#### Part Ordering Options

Part Number	Description	Package	Connectors	Green Status	Product Lifecycle	Export Classification	Recommended Replacement
AMM-7210UC	22 GHz – 57 GHz GaAs Driver Amplifier	UC	<u>Standard</u>	REACH RoHS	Not Recommended for New Design	EAR99	-

## Table Of Contents

### ■ Device Overview

- General Description
- Features
- Applications
- Functional Block Diagram

### ■ Port Configuration and Functions

- Port Diagram
- Port Functions

### ■ Revision History

### ■ Specifications

- Absolute Maximum Ratings
- Fit and MTTF Table
- Package Information
- Recommended Operating Conditions
- Sequencing Requirements
- Electrical Specifications
- Typical Performance Plots
- Typical Marki Mixer Performance Plots with AMM-7210UC LO Driver

### ■ Operation

- Application Information

### ■ Mechanical Data

- Outline Drawing

## Revision History

Revision Code	Revision Date	Comment
-	2021-05-01	Datasheet Initial Release
A	2024-10-28	220-07210 die in module
B	2026-02-13	MTTF Table Added.

## Port Configuration and Functions

### Port Diagram

A port diagram of the AMM-7210UC is shown below.

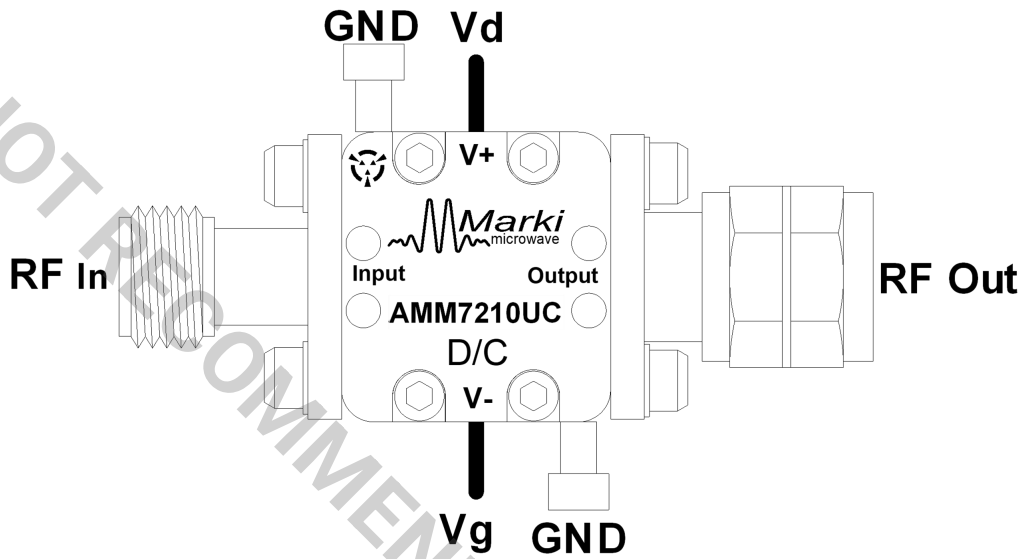

### Port Functions

Port	Function	Connector Type	Description	DC Equivalent Circuit
GND	Ground	-	Exterior housing must be connected to a DC/RF ground potential with high thermal and electrical conductivity.	<b>GND</b> ↓
RF In	RF Input	1.85F	This is the RF Input port of the amplifier module. It is internally DC blocked and RF matched to 50 Ω.	RF In □ — —
RF Out	RF Output	1.85M	This is the RF Output port of the amplifier module. It is internally DC blocked and RF matched to 50 Ω.	— — □ RF Out
Vd	Drain Supply Pin	-	The Vd pin supplies drain voltage to the amplifier IC. Apply gate voltage Vg before applying drain voltage.	Vd ↓
Vg	Gate Bias Pin	-	The Vg pin supplies negative control voltage to the amplifier and controls the amplifier gain. Lower (more negative) voltages on a Vg pad will result in lower drain current and lower small signal gain.	Vg ↓

**Specifications**

**Absolute Maximum Ratings**

The Absolute Maximum Ratings indicate limits beyond which damage may occur to the device. If these limits are exceeded, the device may become inoperable or have a reduced lifetime. This amplifier is designed and characterized in a 50Ω system, and operation in a reflective environment can cause performance degradation.

Parameter	Maximum Rating	Unit
Continuous Power Dissipation (PDISS) (at 85 °C case temp.)	1	W
Maximum Operating Temperature	85	°C
Maximum Storage Temperature	150	°C
Max Junction Temperature for MTTF > 1E6 Hours	175	°C
Minimum Operating Temperature	-40	°C
Minimum Storage Temperature	-65	°C
Negative Bias Voltage (Vg)	-2	V
Positive Drain Supply Current (Id) (with RF Input)	450	mA
Positive Drain Supply Voltage (Vd)	4.5	V
RF Input Power	20	dBm
Thermal Resistance, θJC	90	°C/W

**FIT and MTTF Table**

T (°C)	λ (TIF)	MTTF (hr)	MTTF (yr)
105	2,441.45	4.10E+05	47
85	310.48	3.22E+06	368
55	8.79	1.14E+08	12,992
25	0.12	8.24E+09	941,063

**Package Information**

Parameter	Details	Rating
Weight	Package name: UC	12.4g
Dimensions	-	13.21 x 14.22 mm

**Recommended Operating Conditions**

The Recommended Operating Conditions indicate the limits, inside which the device should be operated, to guarantee the performance given in Electrical Specifications. Operating outside these limits may not necessarily cause damage to the device, but the performance may degrade outside the limits of the electrical specifications. For limits, above which damage may occur, see Absolute Maximum Ratings.

Parameter	Min	Nominal	Max	Unit
Ambient Temperature	-40	25	85	°C
Power Supply DC Current (Id) (No RF Input)	115	180	300	mA
Negative Bias Voltage (Vg)	-0.6	-0.5	-0.4	V
Input Power for Saturation	8	11	13	dBm
Power Supply DC Voltage (Vd)	2.5	3	3	V

Module conditions provided for laboratory settings. Bare die operating conditions should be followed when used in test systems with extended lifetimes.

**Sequencing Requirements**

Turn-on Procedure:

1. Apply negative bias to Vg
2. Apply Vd

Turn-off Procedure:

1. Turn off Vd
2. Turn off Vg

**Note:** RF input power can be injected at any moment in the bias sequencing procedure.

## Electrical Specifications

The electrical specifications apply at TA=+25°C in a 50Ω system. Min and Max limits apply only to our connectorized units and are guaranteed at TA=+25°C. Die are 100% DC tested and RF tested on a per lot basis.

Parameter	Test Conditions	Minimum Frequency (GHz)	Maximum Frequency (GHz)	Min	Typ	Max	Unit
Current Consumption <sup>1</sup>	3V/-0.4V	-	-	-	230	-	mA
Current Consumption <sup>2</sup>	3V/-0.5V	-	-	-	180	-	mA
Current Consumption <sup>3</sup>	3V/-0.6V	-	-	-	130	-	mA
Input IP3	3V/-0.5V, -20 dBm Input Power	22	57	-	13	-	dBm
Input Power for Saturation	3V/-0.5V bias	22	57	-	11	-	dBm
Input Return Loss	3V/-0.5V Bias	22	57	-	14	-	dB
Noise Figure	3V/-0.5V bias	22	57	-	6.3	-	dB
Output IP3	3V/-0.5V, -20 dBm Input Power	22	57	-	27	-	dBm
Output P1dB	3V/-0.5V bias	22	57	-	19	-	dBm
Output Return Loss	3V/-0.5V Bias	22	57	-	14	-	dB
Reverse Isolation	3V/-0.5V Bias	22	57	-	47	-	dB
Saturated Output Power <sup>4</sup>	3V/-0.5V bias	48	57	-	18	-	dBm
Saturated Output Power <sup>5</sup>	3V/-0.5V bias	22	30	-	19	-	dBm
Saturated Output Power <sup>6</sup>	3V/-0.5V bias	30	48	17	20.5	-	dBm
Small Signal Gain	3V/-0.5V bias	22	30	-	13	-	dB
Small Signal Gain	3V/-0.5V bias	45	57	-	11	-	dB
Small Signal Gain	3V/-0.5V bias	30	48	10	14.5	-	dB

[1][2][3] Bias conditions tested with no RF input power. Bias conditions presented as Vd/Vg.

[4][5][6] Saturated Output Power specification defined using the AMM-7210UC P5dB compression curve shown in performance plots.

**Typical Performance Plots**

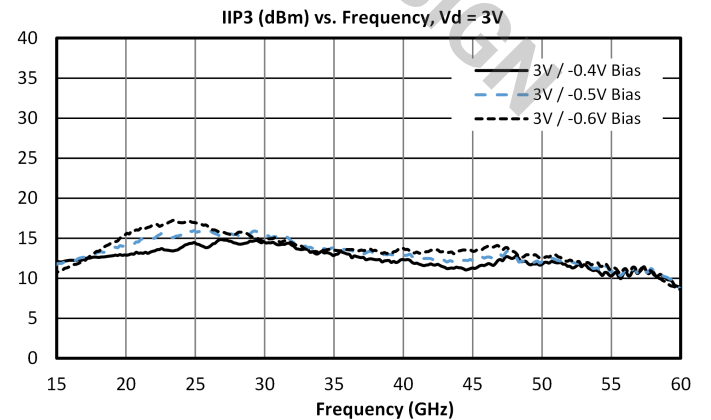
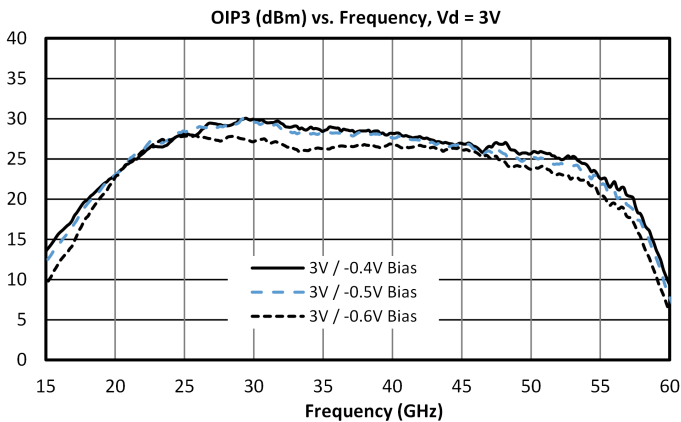
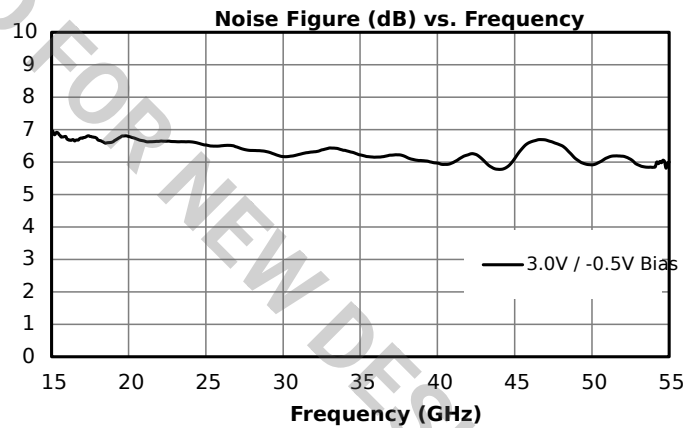
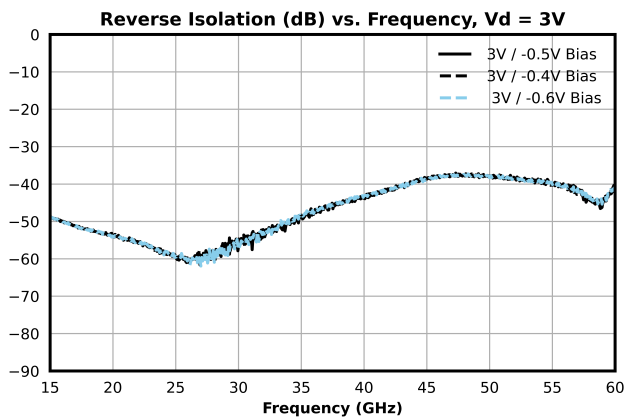
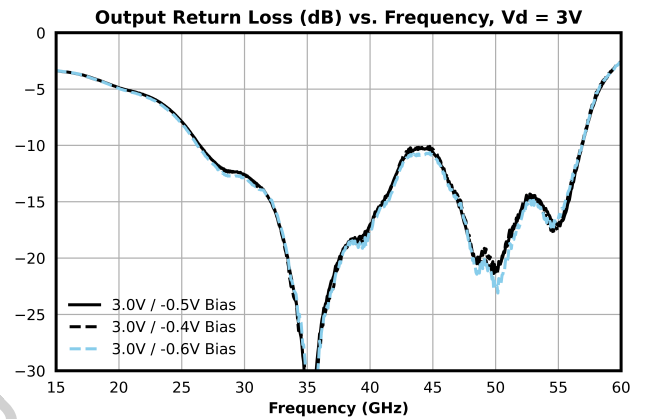
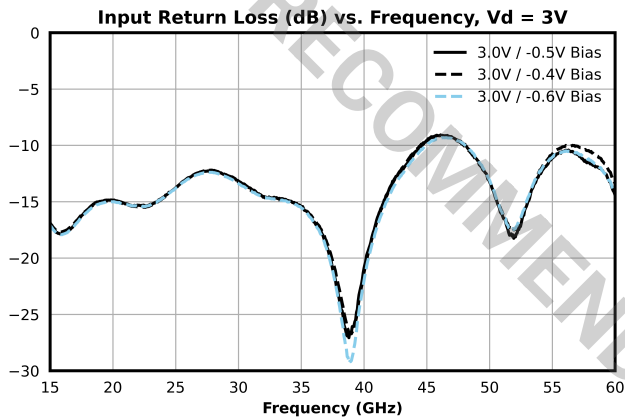
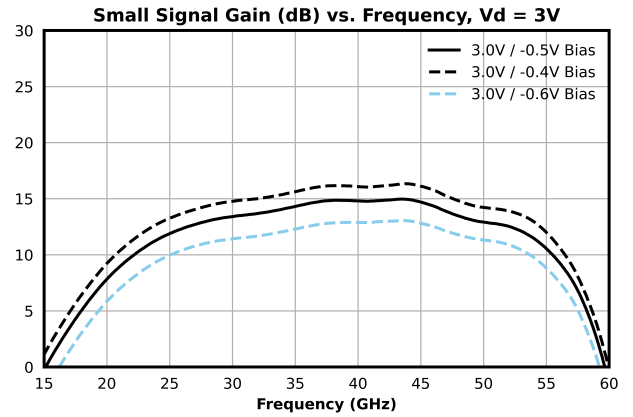
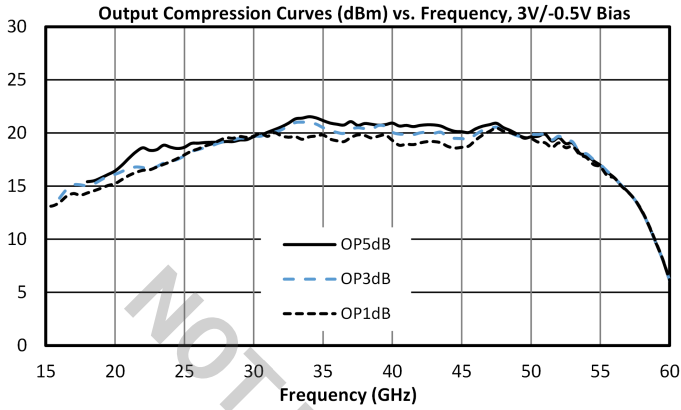

## AMM-7210UC

### 22 GHz – 57 GHz GaAs Driver Amplifier

Saturated Output Power (dBm) vs. Frequency,  
3V/-0.5V Bias, Over Temp.

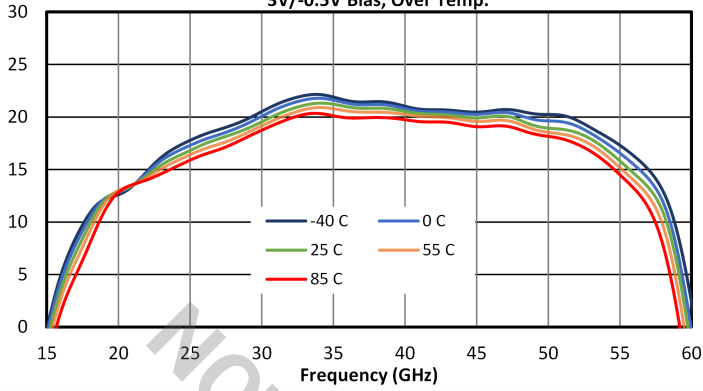

Small Signal Gain (dB) vs. Frequency,  $V_d = 3V$ , Over Temp

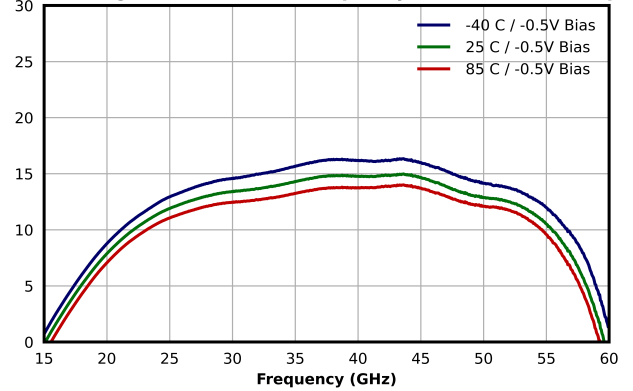

Quiescent Drain Current (mA) vs.  $V_d$

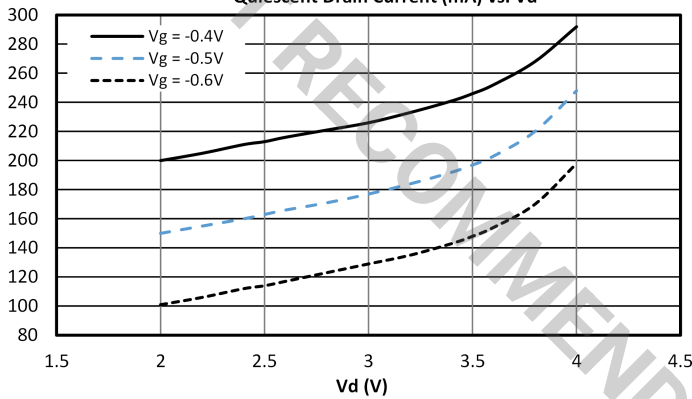

Quiescent Drain Current (mA) vs.  $V_g$

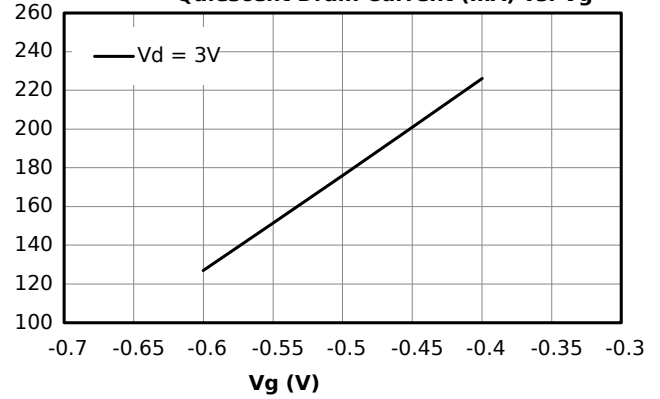

Drain Current (mA) vs. RF Input Power,  $V_d = 3V$ ,  $V_g = -0.5V$

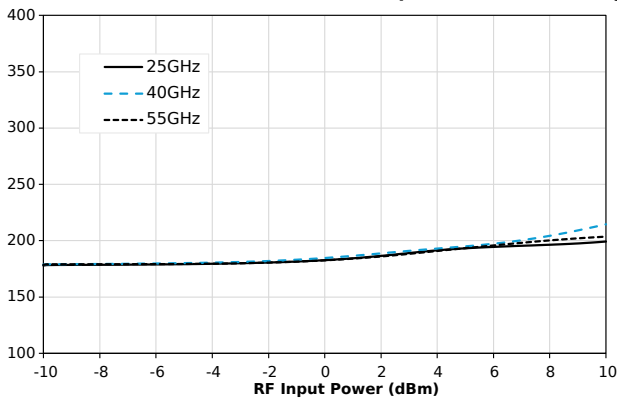

**Typical Marki Mixer Performance Plots with AMM-7210UC LO Driver**

LO Input Powers specified as the input power into the AMM-7210UC LO driver

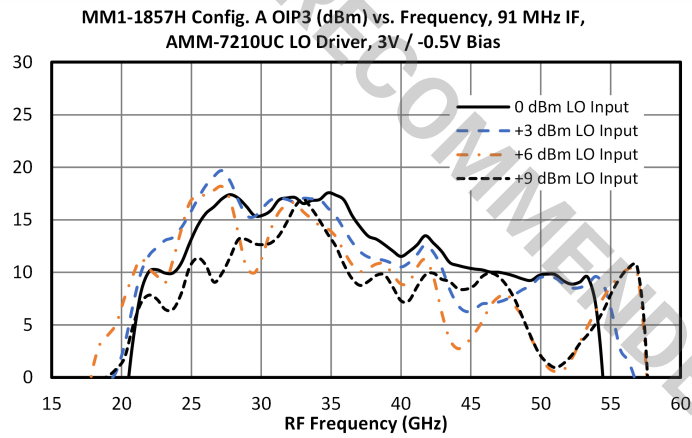
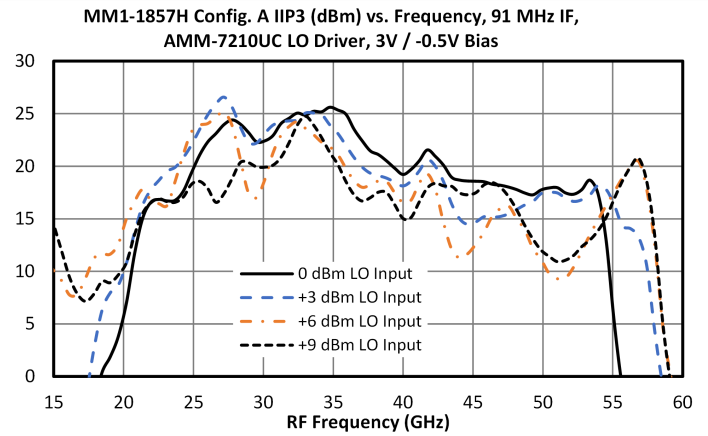
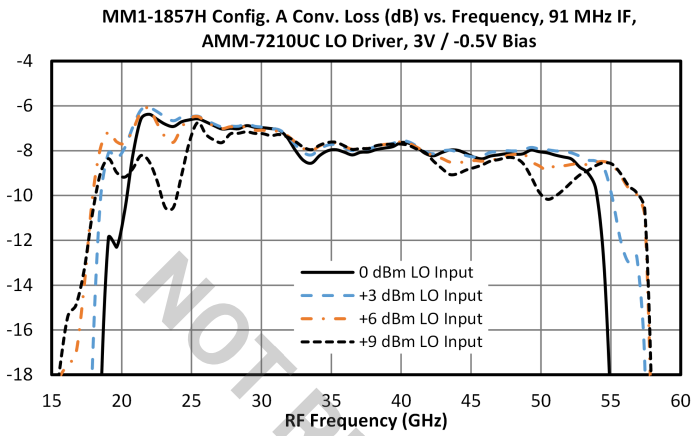

NOT RECOMMENDED FOR NEW DESIGN

## Application Information

### Constant Drain Current vs. Constant Gate Voltage Operation

The AMM-7210 pHEMT amplifier can be biased with a constant gate and drain voltage, or with a constant drain current by regulating the gate voltage. Using a constant gate and drain voltage reduces circuit complexity, but has variable current consumption during operation. However, regulating the gate voltage using feedback circuitry which controls the drain current to a constant value minimizes unit-to-unit variation in gain, output power, and compression points.

Under small signal excitation at a fixed temperature, these two approaches are equivalent because the current draw versus frequency is relatively constant in small signal. However, they will diverge in large signal conditions, where the drain current is affected the input signal's frequency and power. The output power in saturation is relatively unchanged, as it is more strongly dependent on the drain voltage. However, output referred 1 dB compression point will decrease by 2-3 dB when operated with a constant drain current.

NOT RECOMMENDED FOR NEW DESIGN

**Mechanical Data**

**Outline Drawing**

Download : [Outline 3D Drawing](#) | [Outline 3D STP](#)

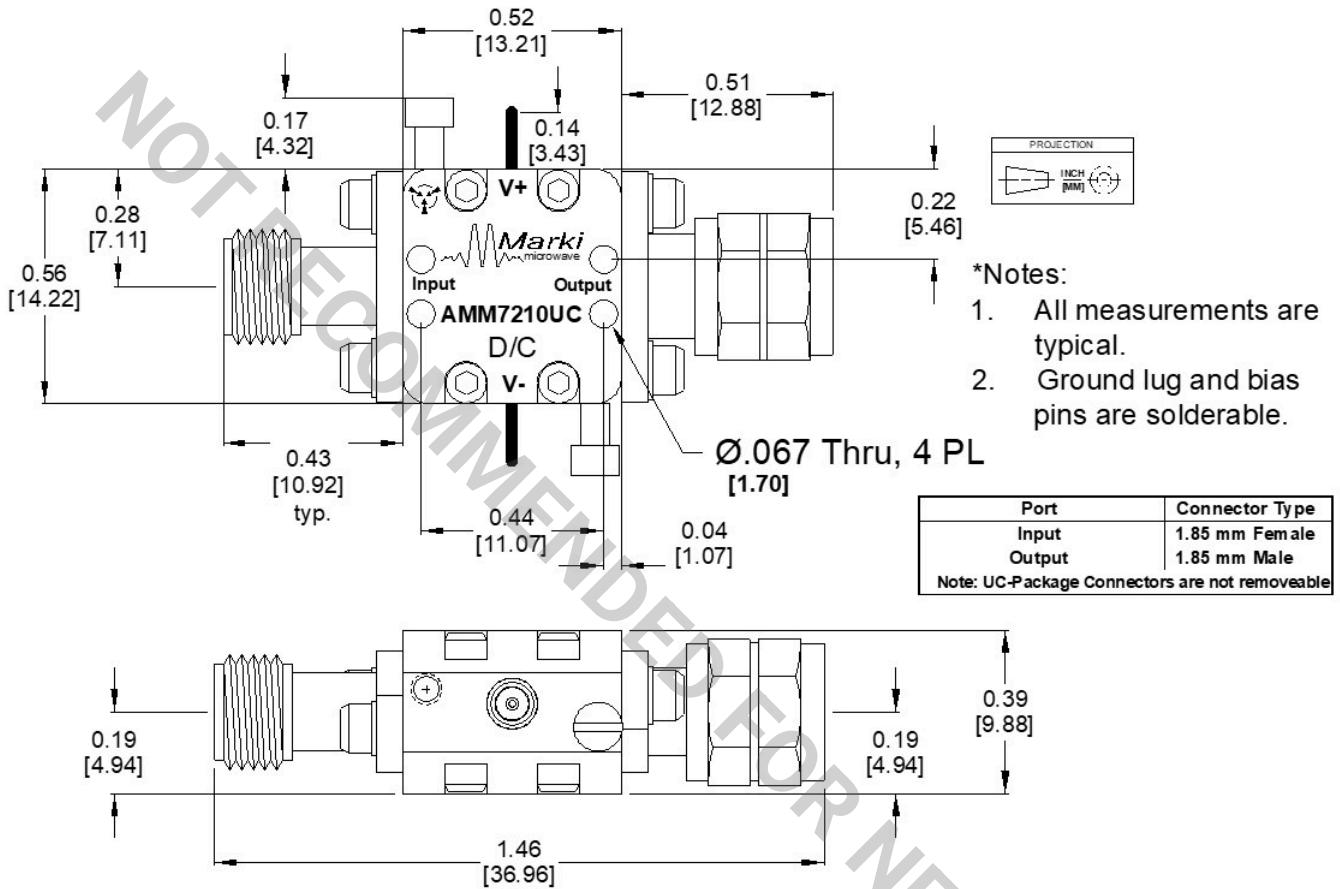

**DISCLAIMER**

MARKI MICROWAVE, LLC., (“MARKI”) PROVIDES TECHNICAL SPECIFICATIONS AND DATA (INCLUDING DATASHEETS), APPLICATION OR OTHER DESIGN ADVICE, WEB TOOLS, AND OTHER INFORMATION AND RESOURCES “AS IS” AND WITH ALL FAULTS. MARKI DISCLAIMS ALL WARRANTIES, EXPRESS OR IMPLIED, INCLUDING, WITHOUT LIMITATION, ANY IMPLIED WARRANTIES OF MERCHANTABILITY, FITNESS FOR A PARTICULAR PURPOSE, OR NON-INFRINGEMENT.

These resources are intended for developers skilled in the art designing with Marki products. You are solely responsible for (1) selecting the appropriate products for your application, (2) designing, validating, and testing your application, and (3) ensuring your application meets applicable standards and other requirements. Marki makes no guarantee regarding the suitability of its products for any particular purpose, nor does Marki assume any liability whatsoever arising out of your use or application of any Marki product.

Marki grants you permission to use these resources only for development of an application that uses Marki products. Other reproduction or use of these resources is strictly prohibited. No license is granted to any other Marki intellectual property or to any third-party intellectual property. Marki reserves the right to make changes to the product(s) or information contained herein without notice.

MARKI MICROWAVE and T3 MIXER are trademarks or registered trademarks of Marki Microwave, LLC. All other trademarks used are the property of their respective owners.

© 2021, 2024, 2026, Marki Microwave, LLC

NOT RECOMMENDED FOR NEW DESIGN