

# MM1-1886LCH-2

## GaAs MMIC mmWave Double Balanced Mixer

### DEVICE OVERVIEW

#### General Description

The MM1-1886LCH-2 is a compact, passive double-balanced MMIC mixer engineered for wideband performance. Operating from 18 to 86 GHz, it features excellent 8.5 dB conversion loss and isolation down to 56 dB. The MM1-1886LCH-2 operates with an LO drive as low as +7 dBm and can be purchased as either a wire-bondable die or a connectorized module.

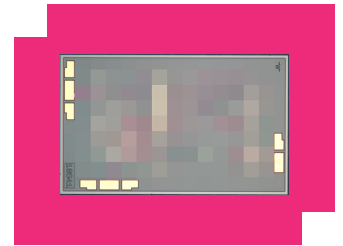

#### Features

- RF/LO Bandwidth, 18 to 86 GHz
- IF Bandwidth, DC to 20 GHz
- Low LO Drive Requirement, +7 dBm Minimum
- LO to RF Isolation, 50 dB Typical
- Excellent Unit-to-Unit Repeatability

#### Applications

- Test and Measurement Equipment
- Fixed RF up converters
- Electronic warfare equipment

#### Functional Block Diagram

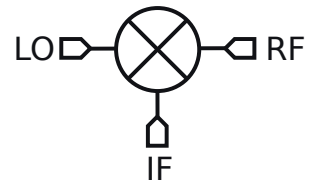

#### Part Ordering Options

Part Number	Description	Package	Green Status	Product Lifecycle	Export Classification
MM1-1886LCH-2	GaAs MMIC mmWave Double Balanced Mixer	CH	REACH RoHS	Released	EAR99

## Table Of Contents

- **Device Overview**
  - General Description
  - Features
  - Applications
  - Functional Block Diagram
- **Port Configuration and Functions**
  - Port Diagram
  - Port Functions
- **Revision History**
- **Specifications**
  - Absolute Maximum Ratings
  - Package Information
  - Recommended Operating Conditions
  - Electrical Specifications
  - Typical Performance Plots
  - Typical Performance Plots: LO Harmonic Isolation
  - Spur Tables
- **Die Mounting Recommendations**
  - Mounting and Bounding Recommendations
- **Mechanical Data**
  - Outline Drawing

## Revision History

Revision Code	Revision Date	Comment
-	2025-12-01	Initial Release



## Port Configuration and Functions

### Port Diagram

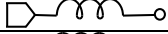

## Port Functions

### Configuration A

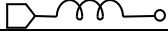
Port	Function	Description	DC Equivalent Circuit
Port 1	LO	Port 1 is DC open for the CH package	
Port 2	IF	Port 2 is diode connected for the CH package	
Port 3	RF	Port 3 is DC open for the CH package	

**Configuration B**

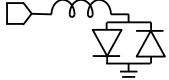
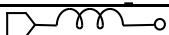
Port	Function	Description	DC Equivalent Circuit
Port 1	RF	Port 1 is DC open for the CH package	
Port 2	IF	Port 2 is diode connected for the CH package	
Port 3	LO	Port 3 is DC open for the CH package	

**Specifications**

**Absolute Maximum Ratings**

Parameter	Maximum Rating	Unit
Maximum Operating Temperature	100	°C
Maximum Storage Temperature	125	°C
Minimum Operating Temperature	-55	°C
Minimum Storage Temperature	-65	°C
Power Handling, at any Port	27	dBm

**Package Information**

Parameter	Details	Rating
Dimensions	-	2.28x1.38mm

**Recommended Operating Conditions**

Parameter	Min	Nominal	Max	Unit
LO Input Power	7	14	16	dBm

**Electrical Specifications**

The electrical specifications apply at TA=+25°C in a 50Ω system. Typical data shown is for the connectorized M package mixer used in the forward direction with a +14 dBm sine wave input. Min and Max limits apply only to our connectorized units and are guaranteed at TA=+25°C. All bare die are 100% DC tested and visually inspected.

Parameter	Port Configuration	Test Conditions	Min	Typ	Max	Unit
RF Frequency Range	-	-	18	-	86	GHz
LO Frequency Range	-	-	18	-	86	GHz
IF Frequency Range	-	-	0	-	20	GHz
Conversion Loss	A	LO/RF=18-86 GHz IF=91 MHz LO drive level=14 dBm	-	8.5	-	dB
Conversion Loss	B	LO/RF=18-86 GHz IF=91 MHz LO drive level=14 dBm	-	10	-	dB
Input IP3	A	LO/RF=18-67 GHz IF=DC-20 GHz LO drive level=14 dBm	-	13.5	-	dBm
Input IP3	B	LO/RF=18-67 GHz IF=DC-20 GHz LO drive level=14 dBm	-	15.5	-	dBm
Input P1dB	A	LO/RF=18-86 GHz IF=DC-20 GHz LO drive level=14 dBm	-	4	-	dBm
Input P1dB	B	LO/RF=18-86 GHz IF=DC-20 GHz LO drive level=14 dBm	-	5	-	dBm
LO-RF Isolation	A	LO/RF=18-86 GHz IF=91 MHz LO drive level=14 dBm	-	50	-	dB
LO-RF Isolation	B	LO/RF=18-86 GHz IF=91 MHz LO drive level=14 dBm	-	50	-	dB
LO-IF Isolation	A	LO/RF=18-86 GHz IF=91 MHz LO drive level=14 dBm	-	35	-	dB
LO-IF Isolation	B	LO/RF=18-86 GHz IF=91 MHz LO drive level=14 dBm	-	56	-	dB
RF-IF Isolation	A	LO/RF=18-86 GHz IF=91 MHz LO drive level=14 dBm	-	33	-	dB
RF-IF Isolation	B	LO/RF=18-86 GHz IF=91 MHz LO drive level=14 dBm	-	55	-	dB
Noise Figure <sup>1</sup>	A	LO/RF=18-86 GHz IF=91 MHz LO drive level=14 dBm	-	8.5	-	dB
Noise Figure <sup>2</sup>	B	LO/RF=18-86 GHz IF=91 MHz LO drive level=14 dBm	-	10	-	dB

[1][2] Mixer Noise Figure typically measures within 0.5 dB of conversion loss for IF frequencies greater than 5 MHz.

### Typical Performance Plots

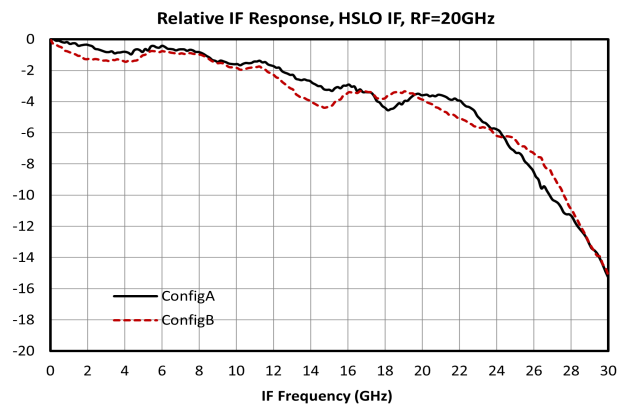
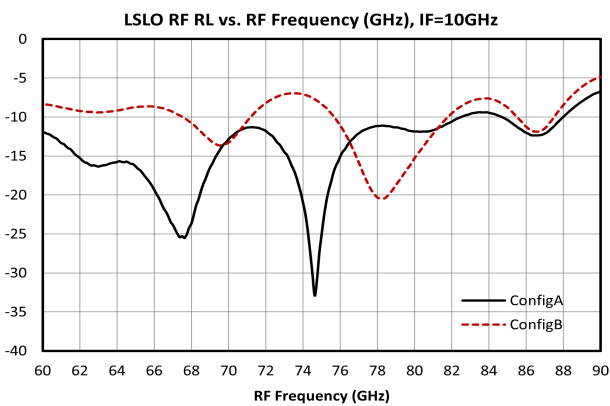
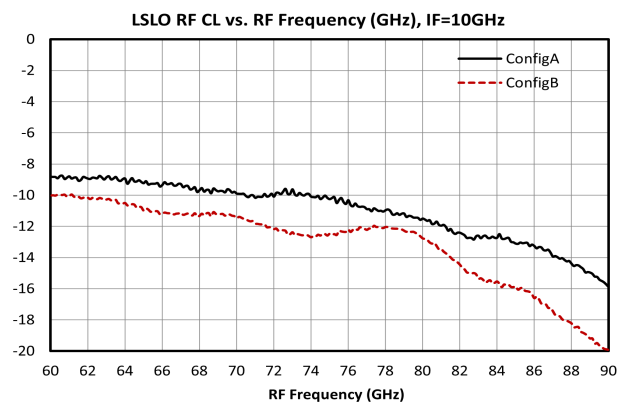
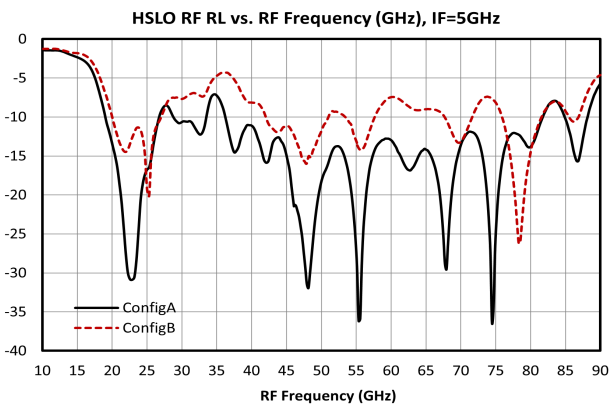
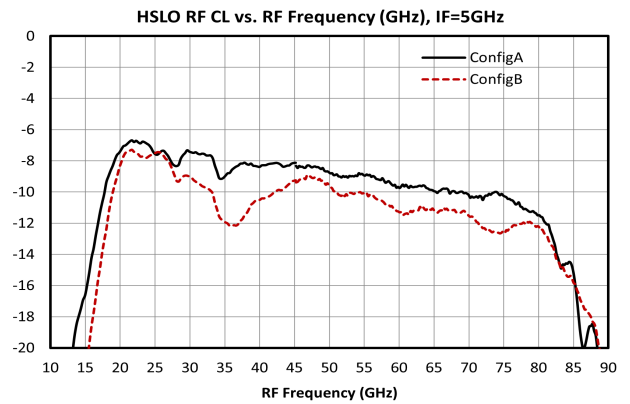
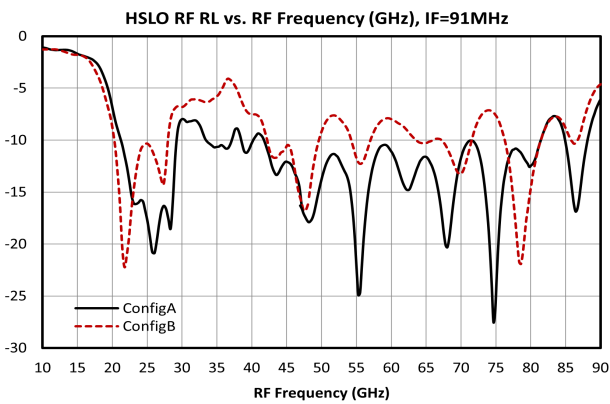
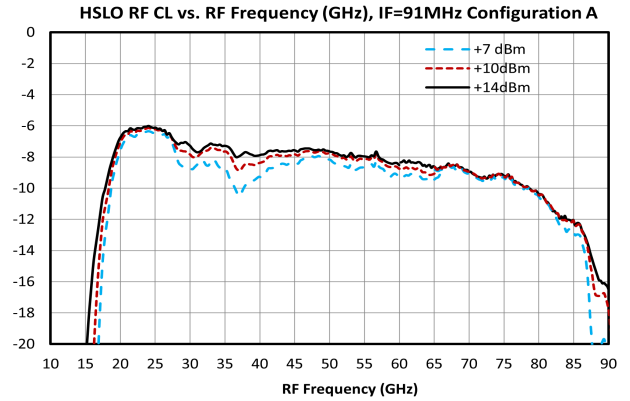
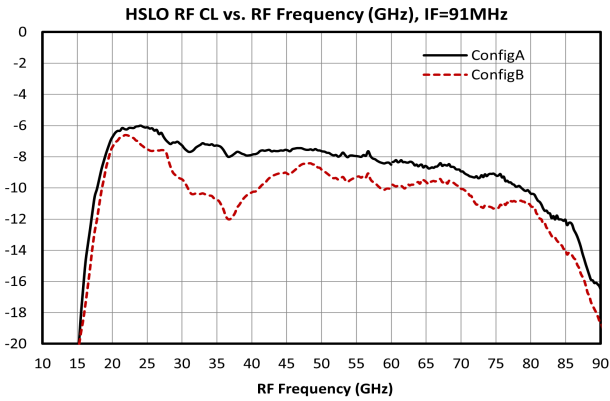

# MM1-1886LCH-2

## GaAs MMIC mmWave Double Balanced Mixer

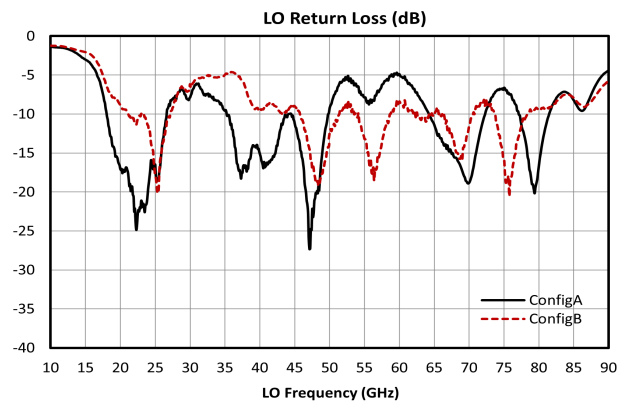
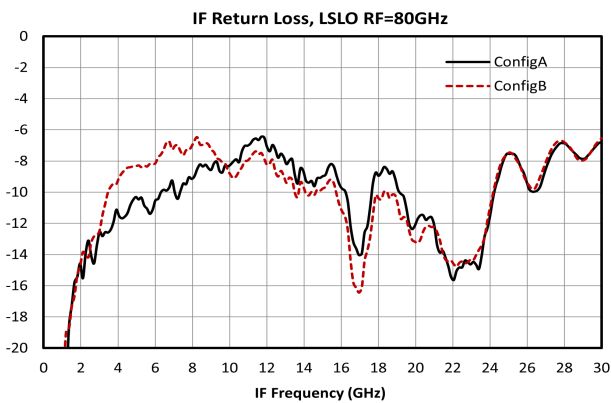
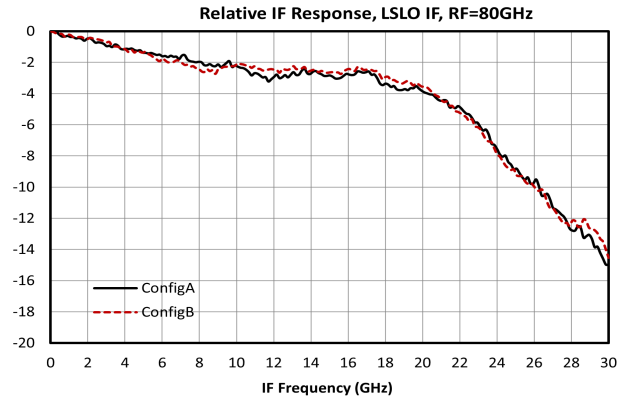
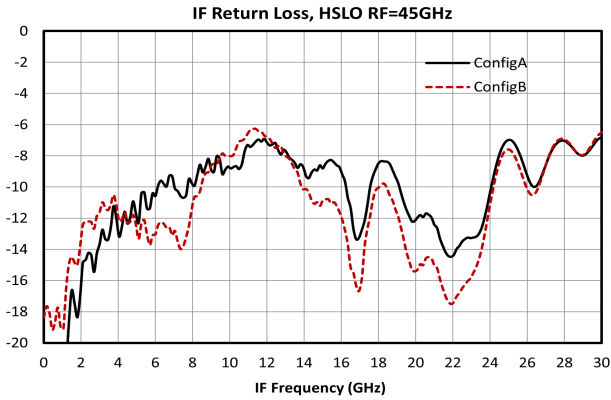
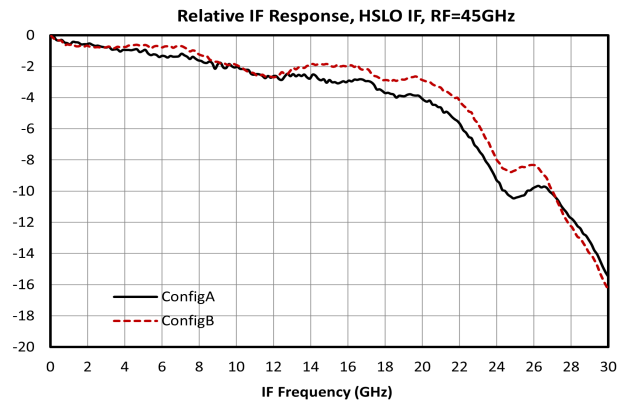
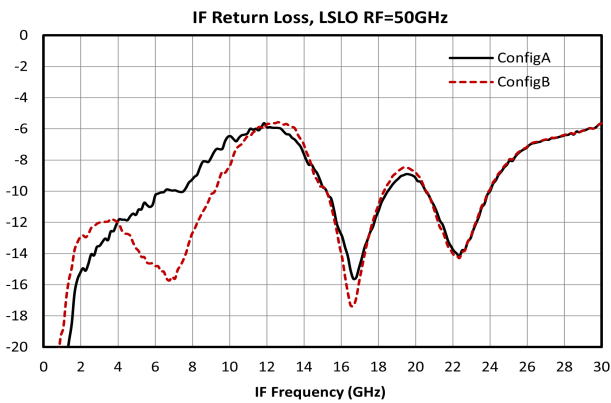
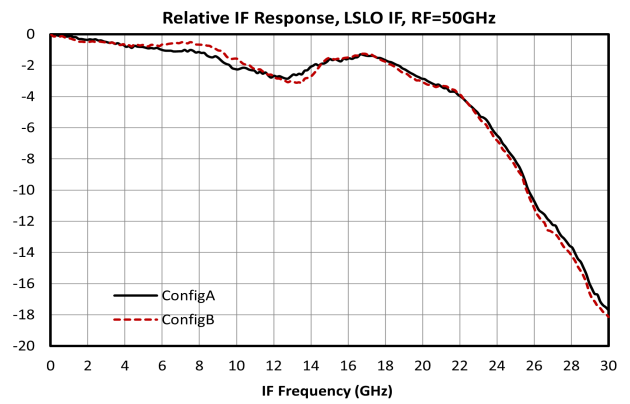
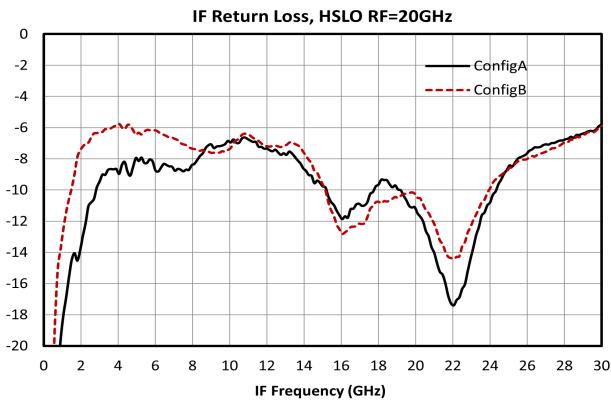

# MM1-1886LCH-2

## GaAs MMIC mmWave Double Balanced Mixer

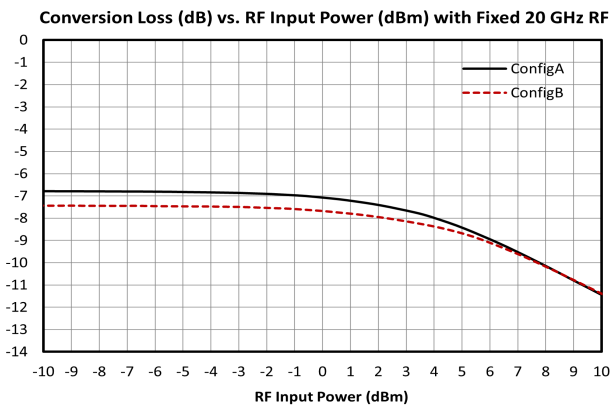
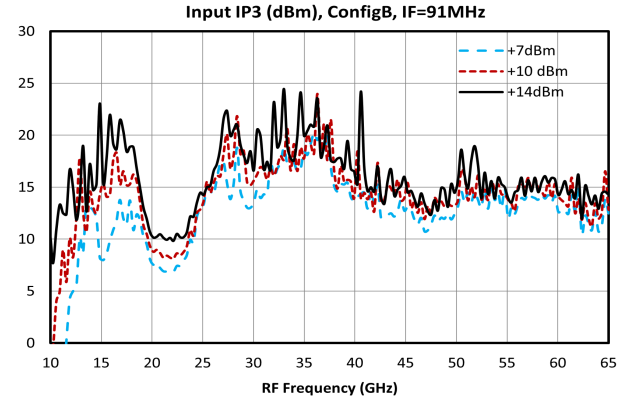
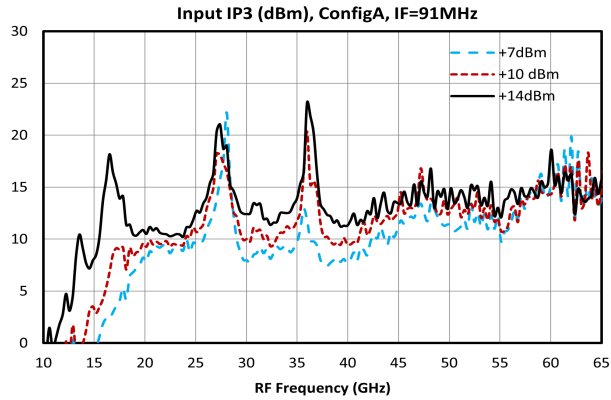
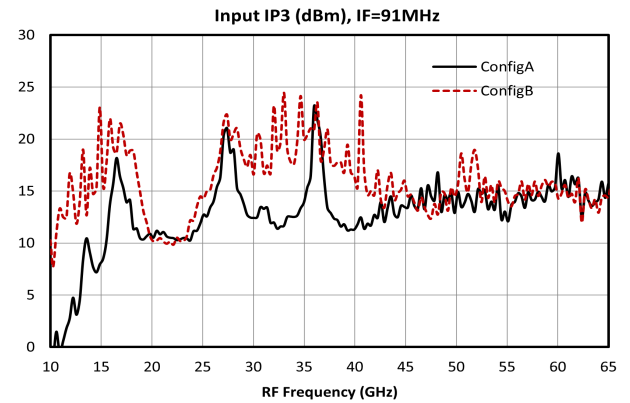
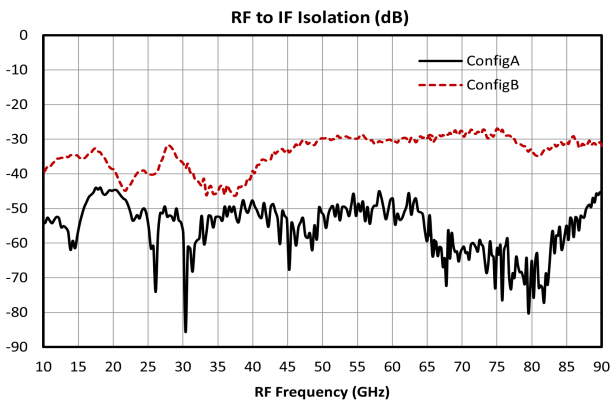
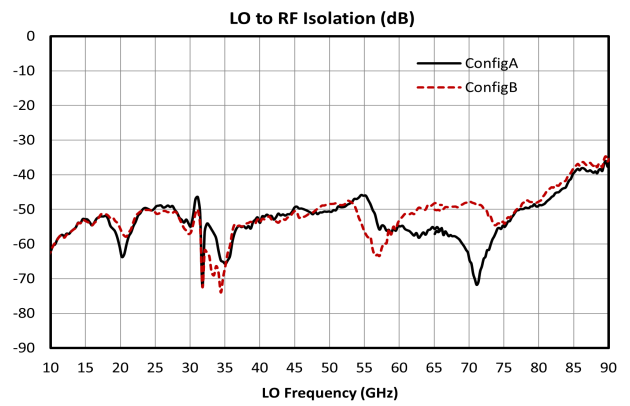
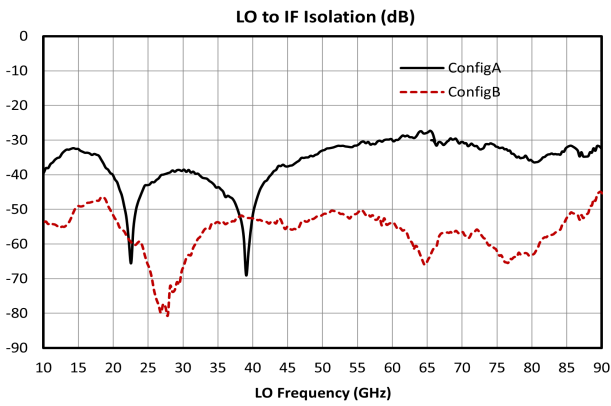

### Typical Performance Plots: LO Harmonic Isolation

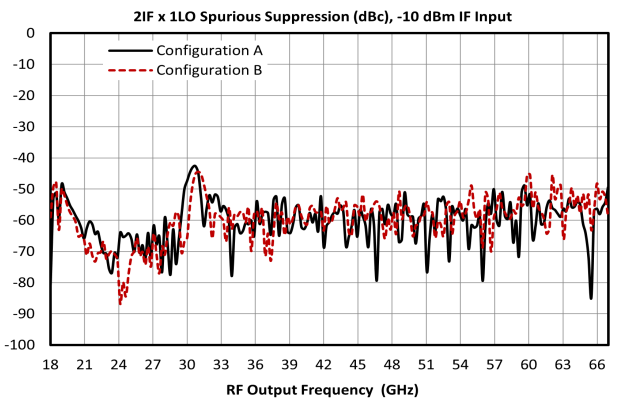
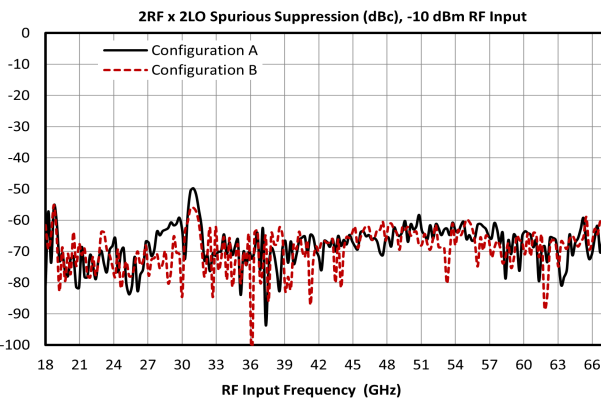
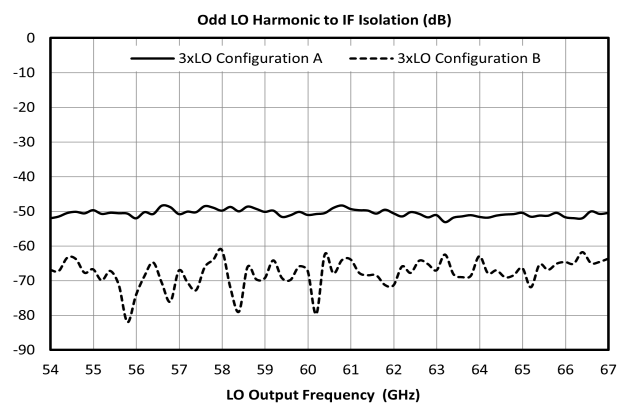
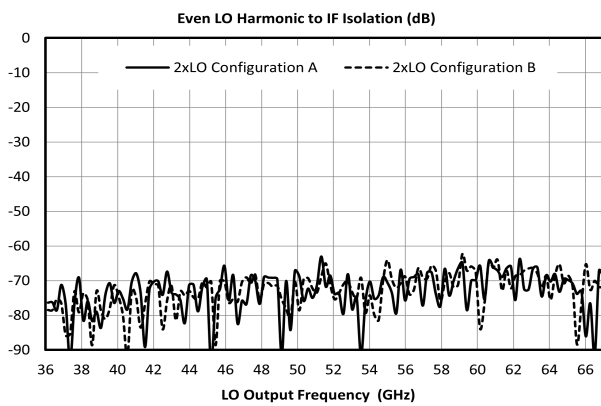
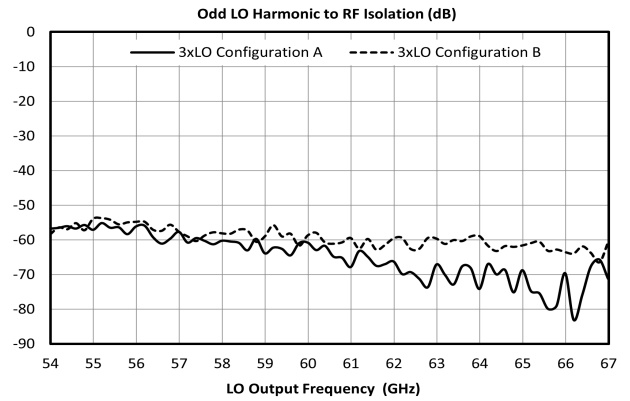
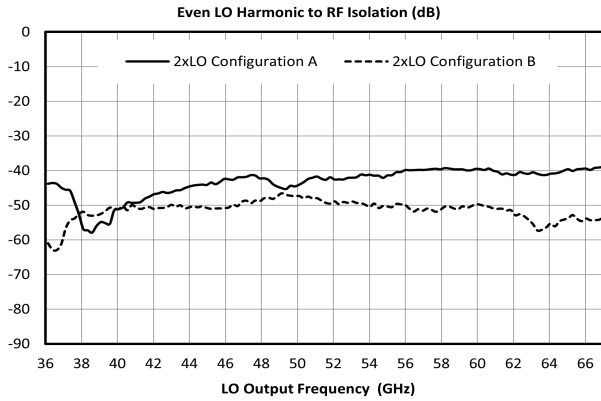

**Spur Table**

**Downconversion Spurious Suppression**

Spurious data is taken by selecting RF and LO frequencies (+mLO+nRF) within the 18 to 67 GHz RF/LO bands, which create a 91 MHz IF spurious output. The mixer is swept across the full spurious band and the mean is calculated. The numbers shown in the table below are for a -10 dBm RF input. Spurious suppression is scaled for different RF power levels by (n-1), where “n” is the RF spur order. For example, the 2RFx2LO spur is 70 dBc for Configuration A for a -10 dBm input, so a -20 dBm RF input creates a spur that is (2-1) x (-10 dB) dB lower, or 80 dBc.

**Typical Downconversion Spurious Suppression (dBc): Configuration A (Configuration B), Sine Wave LO**

-10 dBm RF Input	0xLO	1xLO	2xLO	3xLO	4xLO	5xLO
1xRF	41 (23)	Reference	39 (35)	12 (13)	44 (32)	N/A
2xRF	69 (65)	62 (71)	70 (71)	61 (77)	73 (76)	61 (79)
3xRF	77 (73)	73 (73)	100 (99)	80 (84)	101 (96)	74 (80)
4xRF	93 (91)	109 (114)	113 (112)	110 (112)	112 (112)	110 (109)
5xRF	N/A	124 (123)	122 (120)	123 (122)	124 (120)	123 (120)

**Upconversion Spurious Suppression**

Spurious data is taken by mixing a 91 MHz IF with LO frequencies (+mLO+nIF), which creates an RF within the 18 to 67 GHz RF band. The mixer is swept across the full spurious output band and the mean is calculated. The numbers shown in the table below are for a -10 dBm IF input. Spurious suppression is scaled for different IF input power levels by (n-1), where “n” is the IF spur order. For example, the 2IFx1LO spur is typically 66 dBc for Configuration A for a -10 dBm input, so a -20 dBm IF input creates a spur that is (2-1) x (-10 dB) dB lower, or 76 dBc.

**Typical Upconversion Spurious Suppression (dBc): Configuration A (Configuration B), Sine Wave LO**

-10 dBm IF Input	0xLO	1xLO	2xLO	3xLO	4xLO	5xLO
1xIF	41 (23)	Reference	40 (37)	11 (11)	44 (32)	N/A
2xIF	54 (70)	66 (64)	63 (70)	69 (67)	73 (66)	74 (75)
3xIF	89 (85)	81 (83)	88 (87)	70 (67)	94 (91)	87 (84)
4xIF	92 (98)	104 (101)	96 (98)	97 (94)	100 (99)	101 (100)
5xIF	112 (109)	112 (109)	111 (107)	105 (103)	109 (106)	109 (106)

## Die Mounting Recommendations

### Mounting and Bonding Recommendations

Marki MMICs should be attached directly to a ground plane with conductive epoxy. The ground plane electrical impedance should be as low as practically possible. This will prevent resonances and permit the best possible electrical performance. Datasheet performance is only guaranteed in an environment with a low electrical impedance ground.

**Mounting** - To epoxy the chip, apply a minimum amount of conductive epoxy to the mounting surface so that a thin epoxy fillet is observed around the perimeter of the chip. Cure epoxy according to manufacturer instructions.

**Wire Bonding** - Ball or wedge bond with 0.025 mm (1 mil) diameter pure gold wire. Thermosonic wirebonding with a nominal stage temperature of 150 °C and a ball bonding force of 40 to 50 grams or wedge bonding force of 18 to 22 grams is recommended. Use the minimum level of ultrasonic energy to achieve reliable wirebonds. Wirebonds should be started on the chip and terminated on the package or substrate. All bonds should be as short as possible <0.31 mm (12 mils).

**Circuit Considerations** – 50  $\Omega$  transmission lines should be used for all high frequency connections in and out of the chip. Wirebonds should be kept as short as possible, with multiple wirebonds recommended for higher frequency connections to reduce parasitic inductance. In circumstances where the chip more than .001" thinner than the substrate, a heat spreading spacer tab is optional to further reduce bondwire length and parasitic inductance.

## Handling Precautions

### General Handling

Chips should be handled with care using tweezers or a vacuum collet. Users should take precautions to protect chips from direct human contact that can deposit contaminants, like perspiration and skin oils on any of the chip's surfaces.

### Static Sensitivity

GaAs MMIC devices are sensitive to ESD and should be handled, assembled, tested, and transported only in static protected environments.

**Cleaning and Storage:** Do not attempt to clean the chip with a liquid cleaning system or expose the bare chips to liquid. Once the ESD sensitive bags the chips are stored in are opened, chips should be stored in a dry nitrogen atmosphere.

**Bonding Diagram**

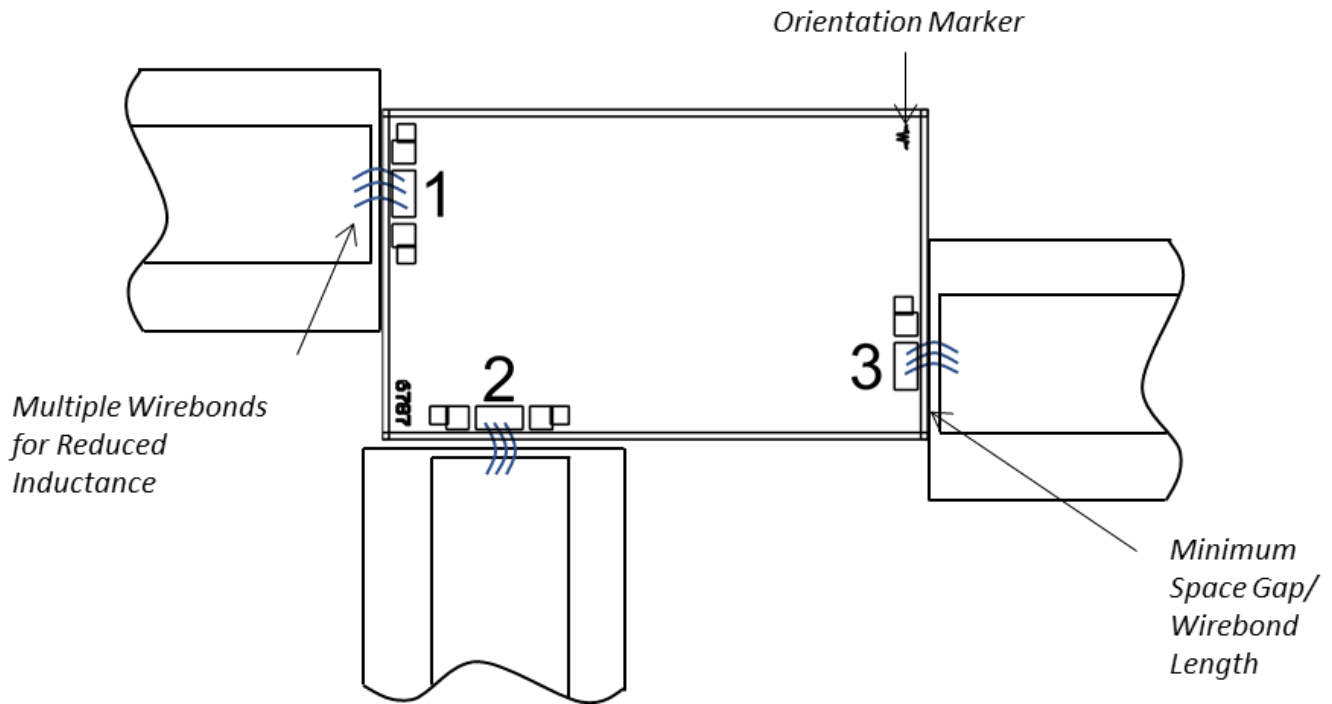

### Mechanical Data

### Outline Drawing

Download : [Outline 2D Drawing](#)

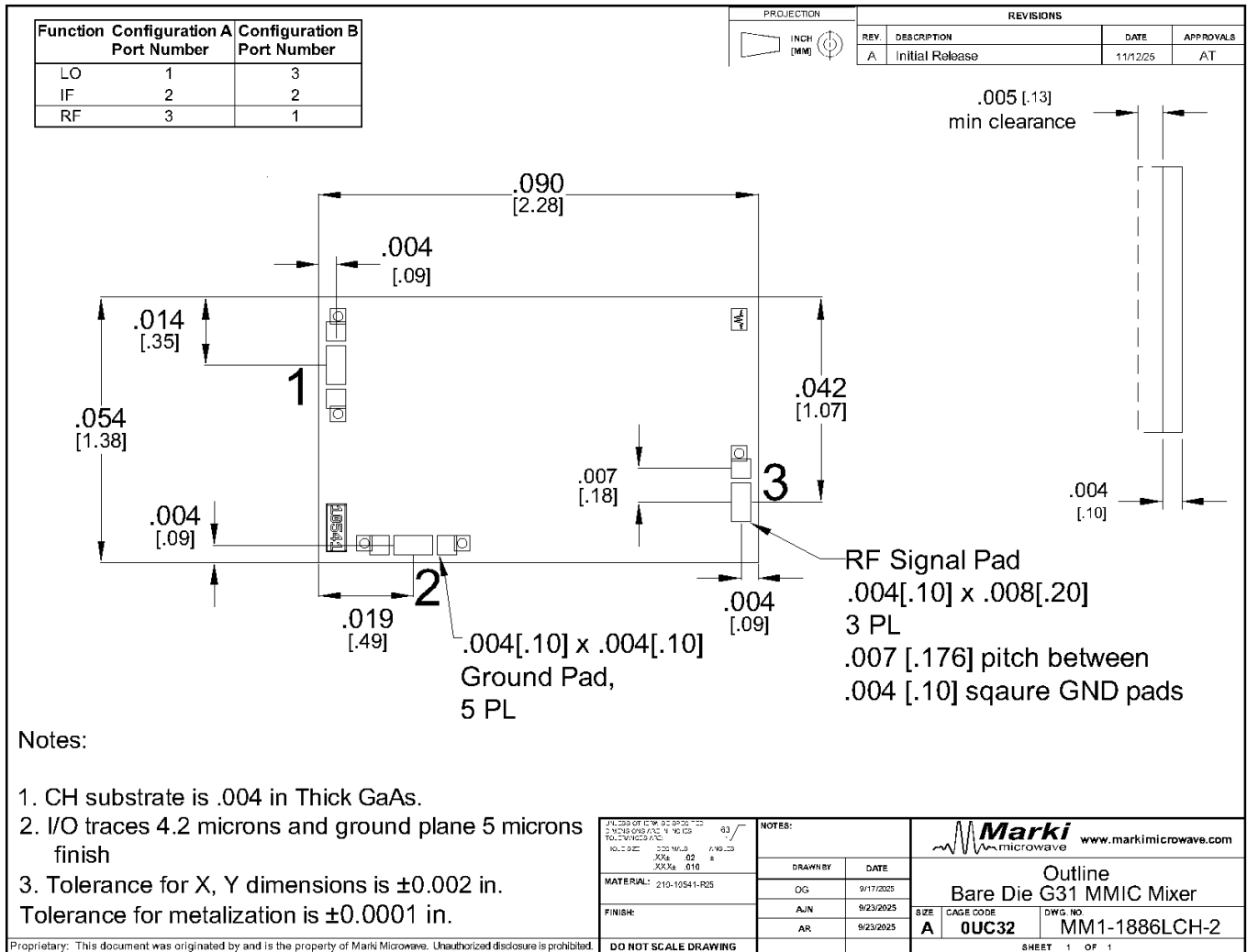

**DISCLAIMER**

MARKI MICROWAVE, LLC., ("MARKI") PROVIDES TECHNICAL SPECIFICATIONS AND DATA (INCLUDING DATASHEETS), APPLICATION OR OTHER DESIGN ADVICE, WEB TOOLS, AND OTHER INFORMATION AND RESOURCES "AS IS" AND WITH ALL FAULTS. MARKI DISCLAIMS ALL WARRANTIES, EXPRESS OR IMPLIED, INCLUDING, WITHOUT LIMITATION, ANY IMPLIED WARRANTIES OF MERCHANTABILITY, FITNESS FOR A PARTICULAR PURPOSE, OR NON-INFRINGEMENT.

These resources are intended for developers skilled in the art designing with Marki products. You are solely responsible for (1) selecting the appropriate products for your application, (2) designing, validating, and testing your application, and (3) ensuring your application meets applicable standards and other requirements. Marki makes no guarantee regarding the suitability of its products for any particular purpose, nor does Marki assume any liability whatsoever arising out of your use or application of any Marki product.

Marki grants you permission to use these resources only for development of an application that uses Marki products. Other reproduction or use of these resources is strictly prohibited. No license is granted to any other Marki intellectual property or to any third-party intellectual property. Marki reserves the right to make changes to the product(s) or information contained herein without notice.

MARKI MICROWAVE and T3 MIXER are trademarks or registered trademarks of Marki Microwave, LLC. All other trademarks used are the property of their respective owners.

© 2025, Marki Microwave, LLC