

APM-7516PSM

1.5-20 GHz Surface Mount Low Phase Noise Amplifier

DEVICE OVERVIEW

General Description

The APM-7516PSM is a broadband low phase noise driver amplifier designed to provide enough power to drive the LO port of an H or L-diode mixer with a range of input powers. This amplifier uses GaAs HBT technology for low phase noise and provides +18 to 23 dBm output power from 1.5 GHz to 20 GHz. This amplifier can be operated with a variety of bias conditions for both low and high-power applications. The APM-7516SM shows less variation in current supply under saturation than similar HBT amplifiers, has a lower thermal resistance, and is less sensitive to damage from high input powers. The APM-7516PSM is packaged in a compact 4 mm QFN with integrated blocking capacitors and power supply inductor for surface mount integration on circuit board-based systems.

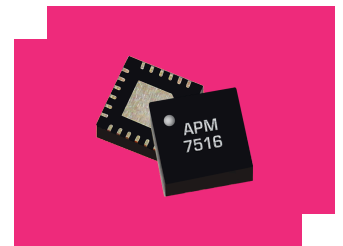

[Download s-parameters here](#)

Features

- More than +18 dBm output power up to 20GHz
- +18 dBm input power rating
- Positive-only biasing
- High Linearity
- Unconditionally stable

Applications

- Mobile test and measurement equipment
- Radar and satellite communications
- 5G transceivers
- Driver amplifier for H and L – diode mixers
- Suitable as a T3 driver

Functional Block Diagram

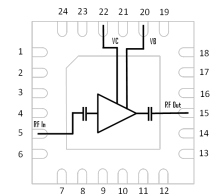

Part Ordering Options

Part Number	Description	Package	Green Status	Product Lifecycle	Export Classification
APM-7516PSM	1.5-20 GHz Surface Mount Low Phase Noise Amplifier	QFN	REACH RoHS	Released	EAR99
EVB-APM-7516PSM	Evaluation Board, Low Phase Noise 1.5-20 GHz Amplifier	EVB	REACH RoHS	Released	EAR99

APM-7516PSM

1.5-20 GHz Surface Mount Low Phase Noise Amplifier

Table Of Contents

- **Device Overview**
 - General Description
 - Features
 - Applications
 - Functional Block Diagram
- **Port Configuration and Functions**
 - Port Diagram
 - Port Functions
- **Revision History**
- **Specifications**
 - Absolute Maximum Ratings
 - Fit and MTTF Table
 - Package Information
 - Recommended Operating Conditions
 - Sequencing Requirements
 - Electrical Specifications
 - APM-7516PSM Typical Performance Plots
- **Operation**
 - Application Information
 - Application Circuit
 - Application Circuit Description
- **Mechanical Data**
 - Outline Drawing
- **Footprint Image**
- **Evaluation Board**
 - Evaluation Board Outline Drawing

Revision History

Revision Code	Revision Date	Comment
-	2022-01-01	Datasheet Initial Release
A	2026-02-13	MTTF Table Added.



Port Configuration and Functions

Port Diagram

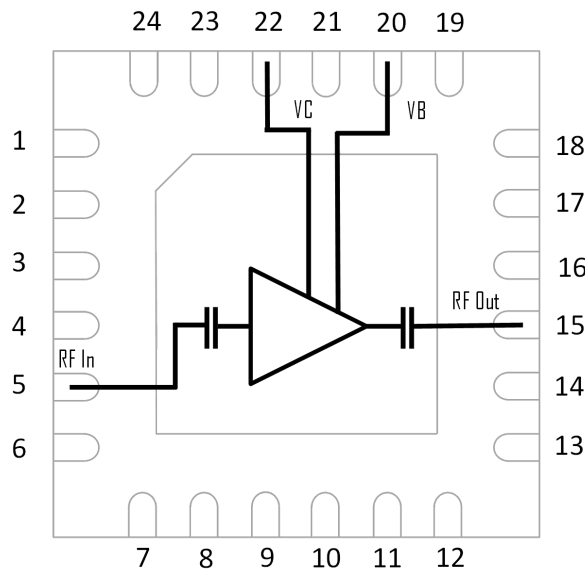
A port diagram of the APM-7516PSM is shown below.

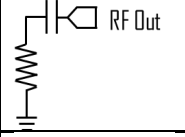
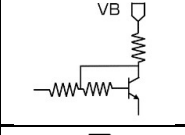
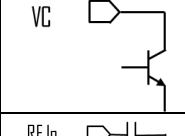

Port Functions

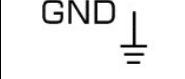
Port	Function	Description	DC Equivalent Circuit
15	RF Output Port	This is the amplifier's RF Output. It is RF matched to 50 Ω and is DC blocked. Must have less than 7:1 VSWR when operating.	
20	Current Mirror Bias Port	Port 20 is the DC voltage bias pad for the current mirror that controls the collector current supplied to the amplifier. See performance plot at different bias condition.	
22	VC Power Supply Port	Pad VC is the amplifier's DC voltage supply pad. See section performance plot at different bias conditions.	
5	RF Input	This is the RF input port of the device, and is RF matched to 50 Ω . This port is AC-coupled; no blocking capacitor is required.	
GND	Ground	IC backside must be connected to a DC/RF ground with high thermal and electrical conductivity.	

APM-7516PSM

1.5-20 GHz Surface Mount Low Phase Noise Amplifier

Specifications

Absolute Maximum Ratings

The Absolute Maximum Ratings indicate limits beyond which damage may occur to the device. If these limits are exceeded, the device may become inoperable or have a reduced lifetime.

Parameter	Maximum Rating	Unit
Bias (Current Mirror) Voltage	7	V
Maximum Operating Temperature	85	°C
Maximum Storage Temperature	150	°C
Max Junction Temperature for MTTF > 1E6 Hours	125	°C
Max Power Dissipation for MTTF of 1E6 hours at 85°C Baseplate Temperature	1200	mW
Minimum Operating Temperature	-40	°C
Minimum Storage Temperature	-65	°C
Output Load VSWR	7	-
Power Supply (Collector) Current (Ic)	240	mA
Power Supply (Collector) Voltage (VC)	7	V
RF Input Power	18	dBm
θJC, Junction to Case Thermal Resistance	33	°C/W

FIT and MTTF Table

T (°C)	λ (TIF)	MTTF (hr)	MTTF (yr)
105	2,441.45	4.10E+05	47
85	310.48	3.22E+06	368
55	8.79	1.14E+08	12,992
25	0.12	8.24E+09	941,063

Package Information

Parameter	Details	Rating
Dimensions	-	4 x 4 mm
Moisture Sensitivity Level	-	MSL 1

Recommended Operating Conditions

The Recommended Operating Conditions indicate the limits, inside which the device should be operated, to guarantee the performance given in Electrical Specifications. Operating outside these limits may not necessarily cause damage to the device, but the performance may degrade outside the limits of the electrical specifications. For limits, above which damage may occur, see Absolute Maximum Ratings.

Parameter	Min	Nominal	Max	Unit
Ambient Temperature	-40	25	85	°C
Positive DC Voltage (VC)	4	5	6	V
Quiescent DC Current (Ic)	-	105	-	mA
DC Current with RF Input (Ic)	-	-	225	mA
Positive DC Current Mirror Voltage (VB)	-	5	-	V
Input Power for Saturation	10	12	14	dBm

Sequencing Requirements

There is no sequencing required to power up or power down the amplifier. Amplifier must have an output load connected when operating.

Electrical Specifications

The electrical specifications apply at TA=+25 °C in a 50 Ω system. QFNs are 100% RF tested.

Parameter	Test Conditions	Minimum Frequency (GHz)	Maximum Frequency (GHz)	Min	Typ	Max	Unit
Input IP3	Power Supply Voltage Vc = 5V Bias Voltage Vb = 5V -5 dBm Input power	1.5	20	-	21	-	dBm
Input Power for Saturation	Power Supply Voltage Vc = 5V Bias Voltage Vb = 5V	1.5	20	-	12	-	dBm
Input Return Loss	Power Supply Voltage Vc = 5V Bias Voltage Vb = 5V	1.5	20	-	16	-	dB
Noise Figure	-	15	20	-	6.5	-	dB
Noise Figure	-	1.5	5	-	9.7	-	dB
Noise Figure	-	5	15	-	5.4	-	dB
Output IP3	Power Supply Voltage Vc = 5V Bias Voltage Vb = 5V -5 dBm Input power	1.5	20	-	33	-	dBm
Output Return Loss	Power Supply Voltage Vc = 5V Bias Voltage Vb = 5V	1.5	20	-	17	-	dB
Power Dissipated as a Linear Signal Amplifier ¹	Power Supply Voltage Vc = 5V Bias Voltage Vb = 5V	1.5	20	-	525	-	mW
Power Dissipated as a Saturated LO Driver Amplifier ²	Power Supply Voltage Vc = 5V Bias Voltage Vb = 5V	1.5	20	-	650	-	mW
Reverse Isolation	Power Supply Voltage Vc = 5V Bias Voltage Vb = 5V	1.5	20	-	34	-	dB
Saturated Output Power	Power Supply Voltage Vc = 5V, Bias Voltage Vb = 5V, P5dB	1.5	20	-	22	-	dBm
Small Signal Gain	Power Supply Voltage Vc = 5V Bias Voltage Vb = 5V	1.5	20	-	11	-	dB

^{[1][2]} Power dissipated = DC input power + RF input power – RF output power. Linear signal amplifier operation is with quiescent current and low output power. Saturated LO Driver calculated with recommended input power for saturation.

APM-7516PSM

1.5-20 GHz Surface Mount Low Phase Noise Amplifier

APM-7516PSM Typical Performance Plots

APM-7516PSM measurements taken in EVAL-APM-7516PSM evaluation board without de-embedding.

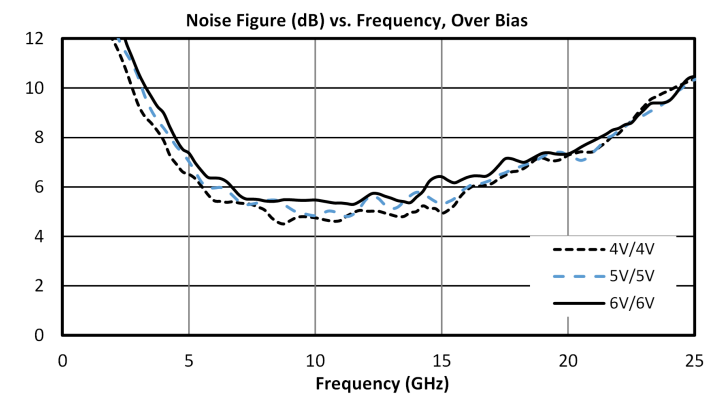
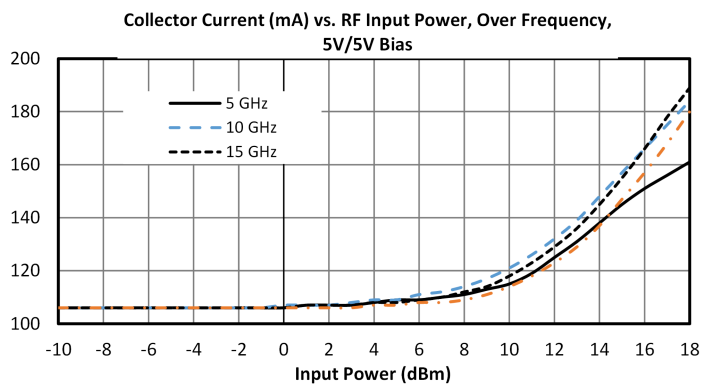
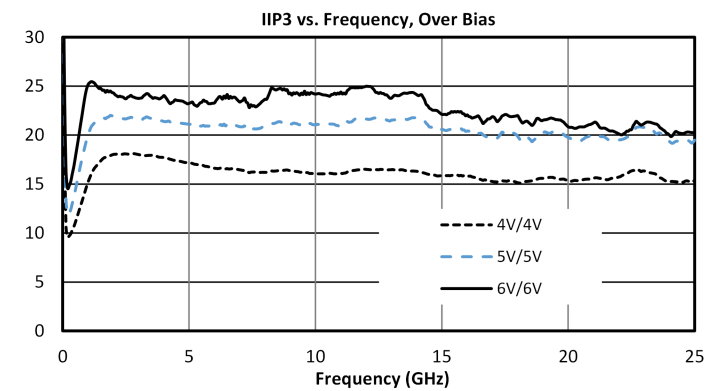
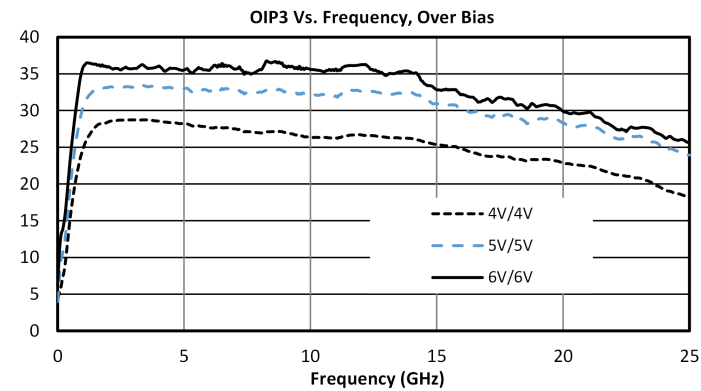
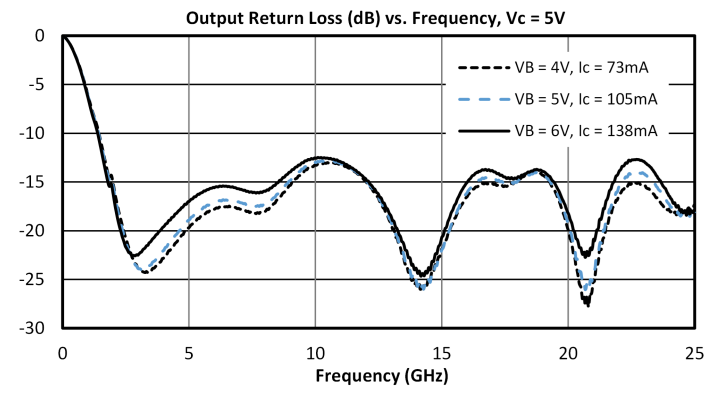
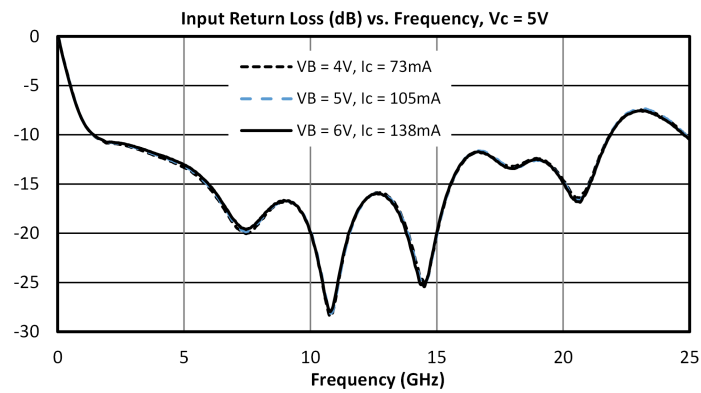
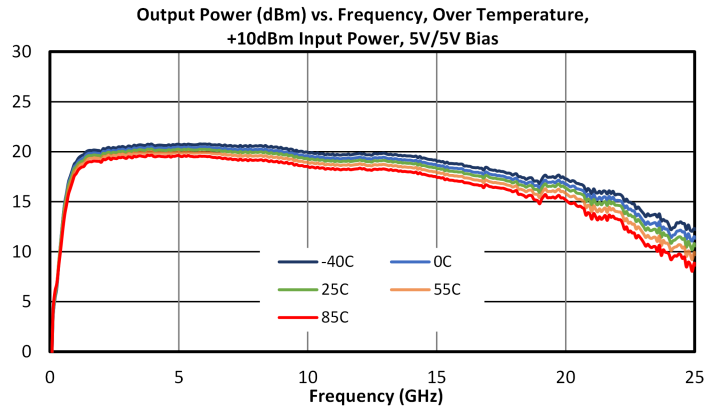
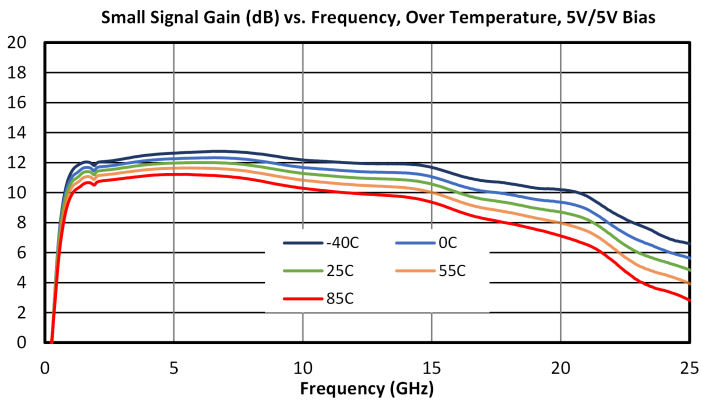

APM-7516PSM

1.5-20 GHz Surface Mount Low Phase Noise Amplifier

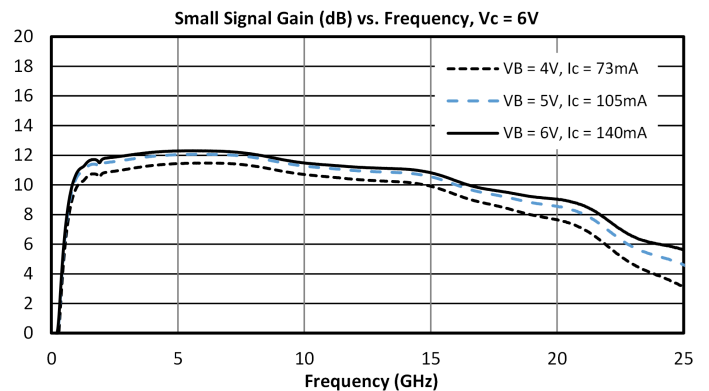
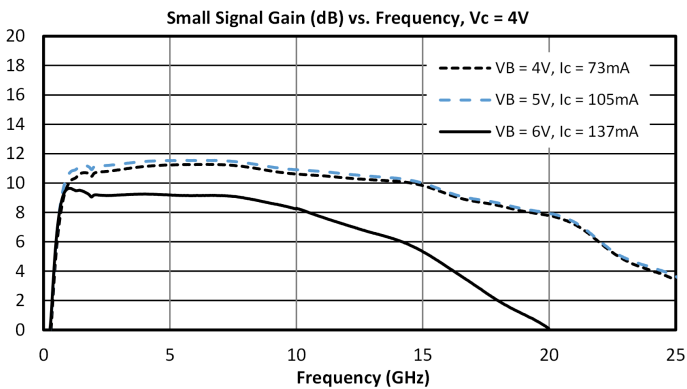
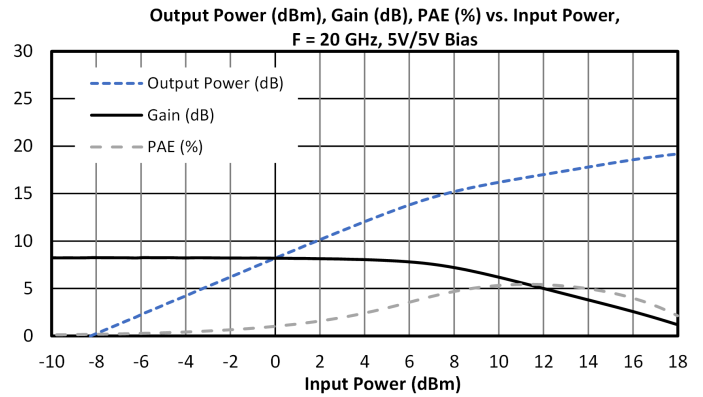
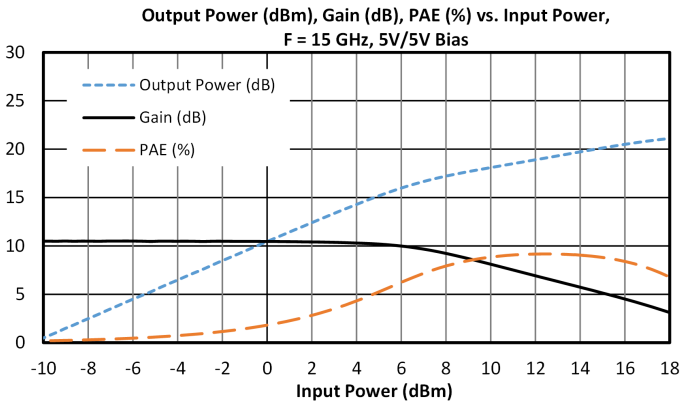
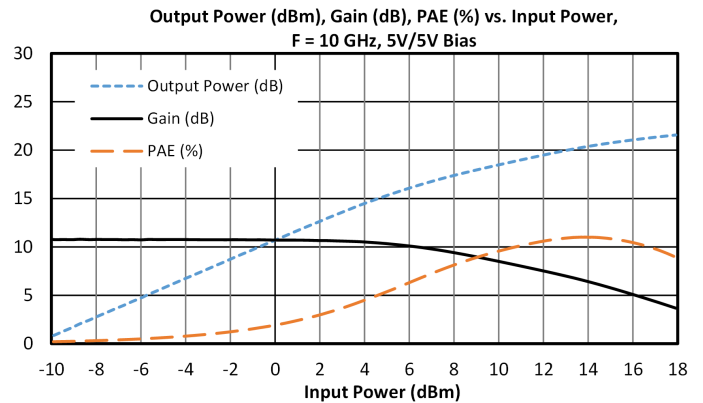
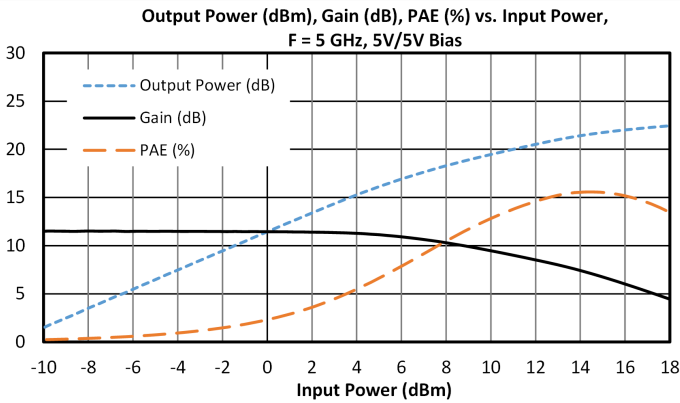
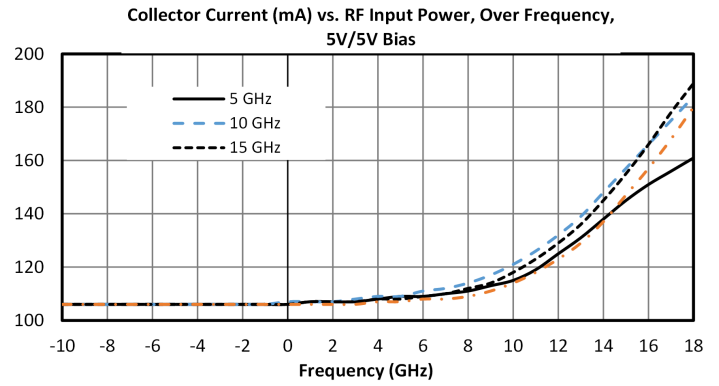
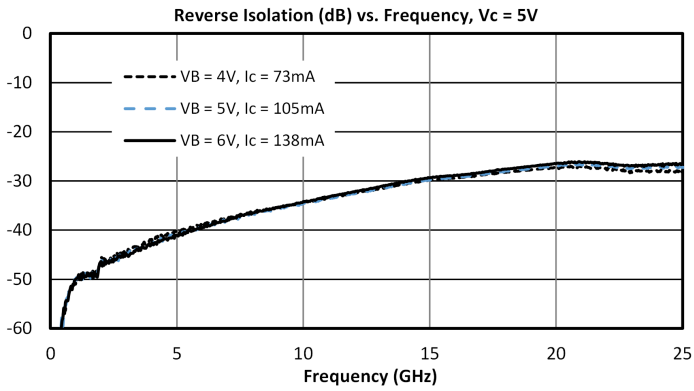

APM-7516PSM

1.5-20 GHz Surface Mount Low Phase Noise Amplifier

Residual Phase Noise (dBc/Hz) vs. Offset Frequency, +5V/+5V Bias, +13 dBm Input Power, F = 4 GHz

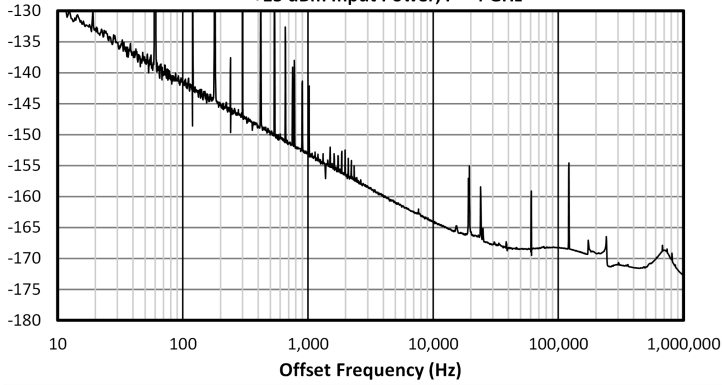

Output Compression Curves (dBm) vs. Frequency, 5V/5V Bias

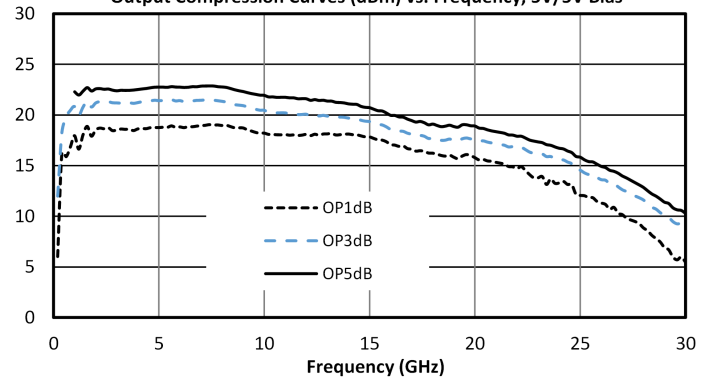

Output Compression Curves (dBm) vs. Frequency, 4v/4v Bias

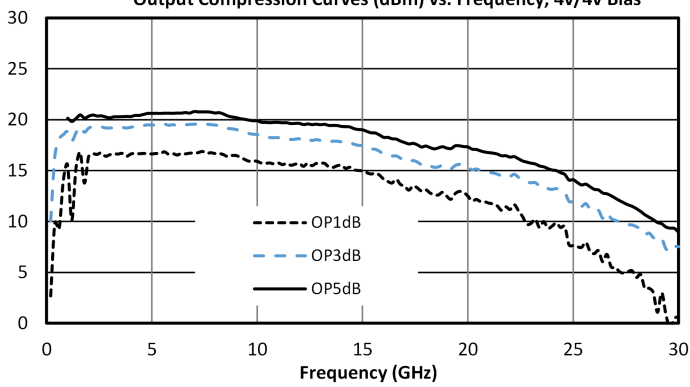

Harmonic Response (dBm) vs. Input Frequency, +10 dBm Input Power, 5V/5V Bias

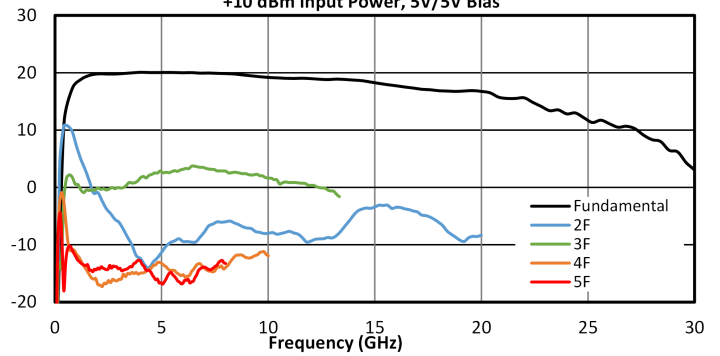

APM-7516PSM

**1.5-20 GHz Surface Mount Low Phase Noise
Amplifier**

Application Information

Below is the recommended application circuit for the APM-7516PSM.

APM-7516PSM

1.5-20 GHz Surface Mount Low Phase Noise Amplifier

Application Circuit

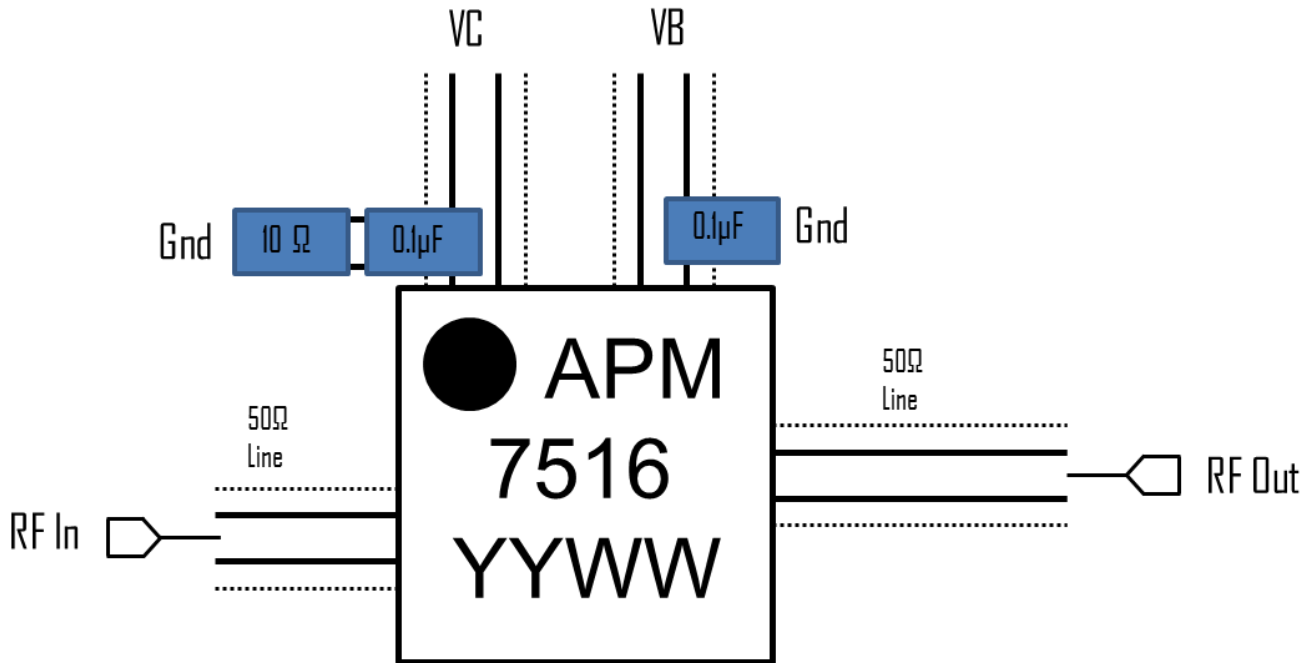

APM-7516PSM

1.5-20 GHz Surface Mount Low Phase Noise Amplifier

Application Circuit Description

RF input and output should be soldered to 50 Ω traces.

Description	Sample Part Number
0402 Capacitor .1uF 16V	Kyocera 0402YG104ZAT2A
0402 Resistor 10 Ohm	Vishay Dale CRCW040210R0FKED

APM-7516PSM

1.5-20 GHz Surface Mount Low Phase Noise Amplifier

Mechanical Data

Outline Drawing

Download : [Outline 2D Drawing](#) | [Outline 3D Drawing](#) | [Outline 3D STP](#)

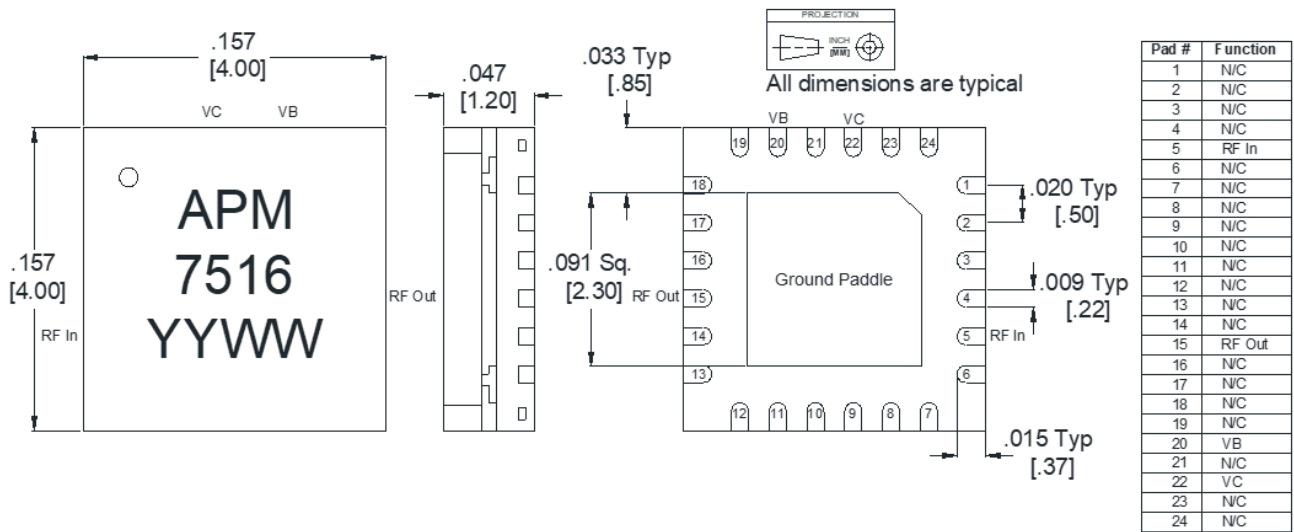

Notes:

1. Substrate Material is Plastic.
2. I/O Leads and Die Paddle are 0.05 microns Au over 0.02 microns Pd over 0.5 microns Ni.
3. All unconnected pins should be connected to PCB RF ground.

APM-7516PSM

1.5-20 GHz Surface Mount Low Phase Noise Amplifier

Footprint Image

Download : [Footprint Drawing](#)

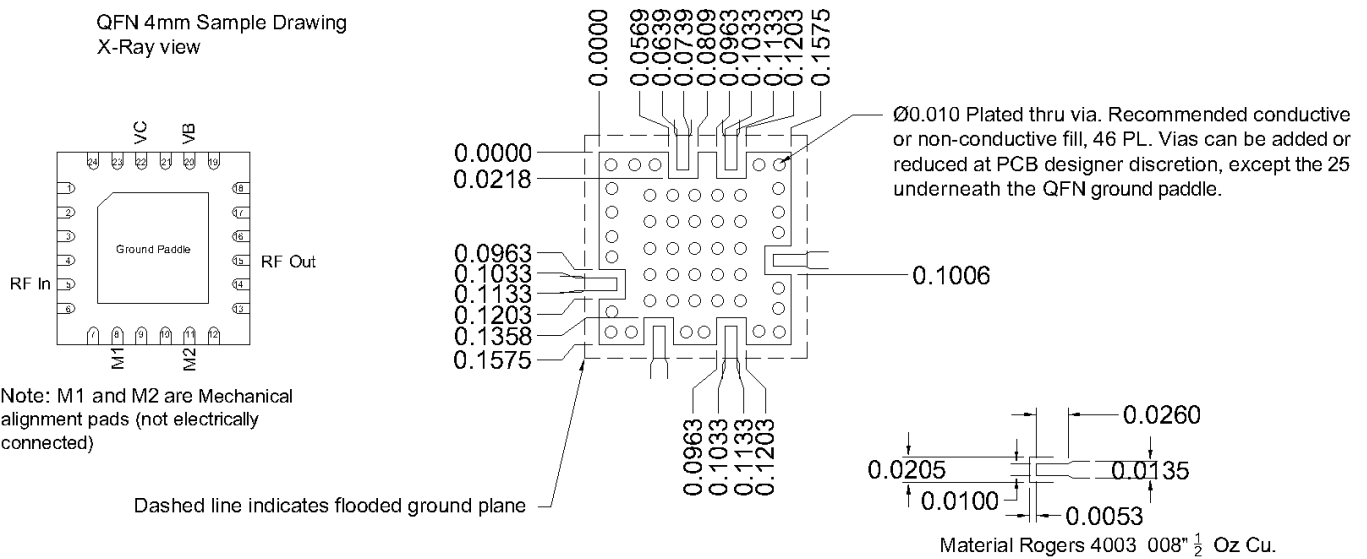

APM-7516PSM

1.5-20 GHz Surface Mount Low Phase Noise Amplifier

Evaluation Board - Outline Drawing

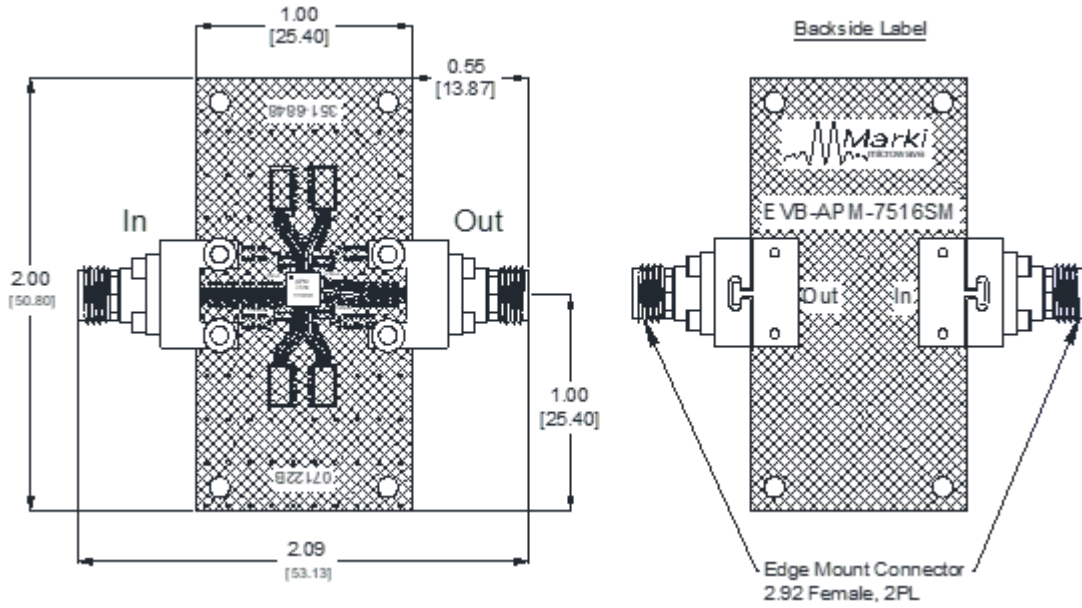

APM-7516PSM

1.5-20 GHz Surface Mount Low Phase Noise Amplifier

DISCLAIMER

MARKI MICROWAVE, LLC., ("MARKI") PROVIDES TECHNICAL SPECIFICATIONS AND DATA (INCLUDING DATASHEETS), APPLICATION OR OTHER DESIGN ADVICE, WEB TOOLS, AND OTHER INFORMATION AND RESOURCES "AS IS" AND WITH ALL FAULTS. MARKI DISCLAIMS ALL WARRANTIES, EXPRESS OR IMPLIED, INCLUDING, WITHOUT LIMITATION, ANY IMPLIED WARRANTIES OF MERCHANTABILITY, FITNESS FOR A PARTICULAR PURPOSE, OR NON-INFRINGEMENT.

These resources are intended for developers skilled in the art designing with Marki products. You are solely responsible for (1) selecting the appropriate products for your application, (2) designing, validating, and testing your application, and (3) ensuring your application meets applicable standards and other requirements. Marki makes no guarantee regarding the suitability of its products for any particular purpose, nor does Marki assume any liability whatsoever arising out of your use or application of any Marki product.

Marki grants you permission to use these resources only for development of an application that uses Marki products. Other reproduction or use of these resources is strictly prohibited. No license is granted to any other Marki intellectual property or to any third-party intellectual property. Marki reserves the right to make changes to the product(s) or information contained herein without notice.

MARKI MICROWAVE and T3 MIXER are trademarks or registered trademarks of Marki Microwave, LLC. All other trademarks used are the property of their respective owners.

© 2022, 2026, Marki Microwave, LLC