

# APM-6848SM

## 2-30 GHz Surface Mount Low Phase Noise Amplifier

### DEVICE OVERVIEW

#### General Description

The APM-6848SM is an integrated 2-stage broadband, low phase noise LO driver amplifier designed to provide a saturated +20 dBm output power from a 0-4 dBm input power with low DC power consumption, packaged in a 4mm QFN. This amplifier uses GaAs HBT technology for low phase noise, and is optimized to provide enough power to drive the LO port of an S-diode mixer from 2 GHz to 20 GHz or an H or L diode mixer from 2 GHz to 32 GHz. This amplifier can be operated with a variety of bias conditions including VC=VB=5V for both low power and high power applications.

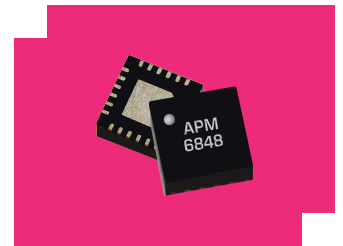

#### Features

- -165 dBc/Hz phase noise at 10 kHz offset frequency
- Power and gain control
- +22 dB gain
- Low DC power consumption
- Positive-only biasing
- No sequencing required
- Unconditionally stable
- Integrated DC blocks – No bias-tees or off-chip blocking required

#### Applications

- Mobile test and measurement equipment
- Radar
- SATCOM
- 5G transceivers
- Driver amplifier for S, H, and L – diode mixers
- Suitable as a T3 mixer driver

#### Functional Block Diagram

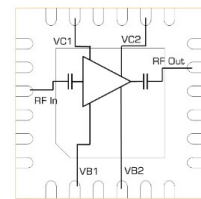

#### Part Ordering Options

Part Number	Description	Package	Green Status	Product Lifecycle	Export Classification
APM-6848SM	2-30 GHz Surface Mount Low Phase Noise Amplifier	QFN	REACH RoHS	Obsolete	EAR99
EVAL-APM-6848SM	Evaluation Board, 2-30 GHz Surface Mount Low Phase Noise Amplifier	EVAL	REACH RoHS	Obsolete	EAR99

## APM-6848SM

### 2-30 GHz Surface Mount Low Phase Noise Amplifier

#### Table Of Contents

- **Device Overview**
  - General Description
  - Features
  - Applications
  - Functional Block Diagram
- **Port Configuration and Functions**
  - Port Diagram
  - Port Functions
- **Revision History**
- **Specifications**
  - Absolute Maximum Ratings
  - Package Information
  - Recommended Operating Conditions
  - Sequencing Requirements
  - Electrical Specifications
  - Typical Performance Plots
  - Time Domain Plots
  - Conversion Loss of Marki Mixers Using APM-6848SM as LO Driver
- **Operation**
  - Application Information
- **Mechanical Data**
  - Outline Drawing
- **Footprint Image**
- **Evaluation Board**

#### Revision History

Revision Code	Revision Date	Comment
-	2019-12-01	Datasheet Initial Release
A	2020-05-01	Updated EVAL drawing and status
B	2020-07-01	Updated Min small signal gain spec
C	2020-07-01	Updated Max Operating Temperature
D	2020-11-01	Updated Thermal Specs and Min Specs, added link to landing pattern
E	2020-12-01	Adjusted performance plots to adhere to Max input power spec.



**Port Configuration and Functions**

**Port Diagram**

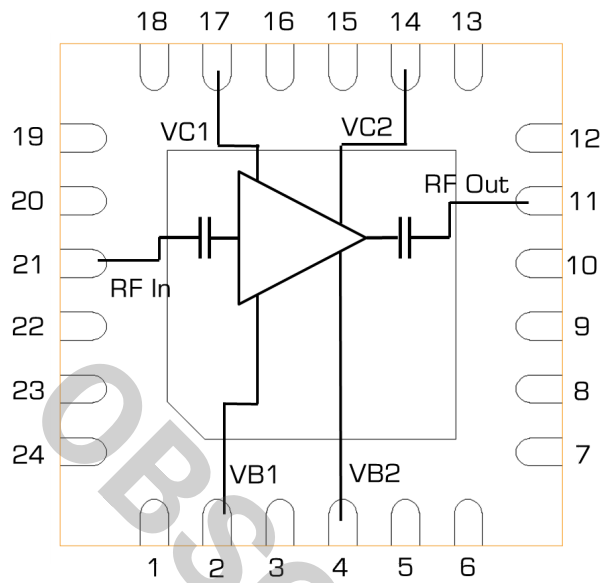
A top-down port diagram of the APM-6848SM is shown below.

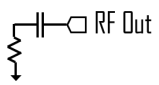
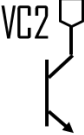
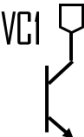
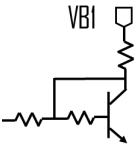
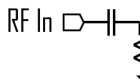
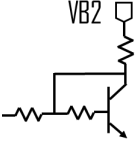

#### Port Functions

Port	Function	Description	Equivalent Circuit for Package
11	RF Output	This is the RF Output port of the amplifier die. It is internally DC blocked and RF matched to 50 $\Omega$ . Must have less than 7:1 VSWR when operating with voltage larger than 5V on VC1 or VC2.	
14	Collector Supply Port 2	Pad VC2 is the DC voltage supply pad to the 2nd stage of the amplifier IC. Larger VC voltage will result in larger power consumption and larger power output. See typical performance plots for performance at different bias conditions.	
17	Collector Supply Port 1	Pad VC1 is the DC voltage supply pad for the 1st stage of the amplifier IC. See Typical performance plots for performance at different bias conditions.	
2	Base Supply Port 1	Pad VB1 is the DC voltage supply pad for a current mirror which controls the collector current of the 1st stage (Ic1). Larger voltages result in a higher current draw through pad VC1, effectively functioning as a gain control pin for the 1st stage of the amplifier. See typical performance plots for performance at different bias conditions.	
21	RF Input	This is the RF Input port of the amplifier die. It is internally DC blocked and RF matched to 50 $\Omega$ .	
4	Base Supply Port 2	Pad VB2 is the DC voltage supply pad for a current mirror which controls the collector current of the 2nd stage (Ic2). Larger voltages result in a higher current draw through pad VC2, effectively functioning as a gain control pin for the 2nd stage of the amplifier. See typical performance plots for performance at different bias conditions.	
GND	Ground	Backside of the IC must be connected to a DC/RF ground with high thermal and electrical conductivity.	

## Specifications

### Absolute Maximum Ratings

The Absolute Maximum Ratings indicate limits beyond which damage may occur to the device. If these limits are exceeded, the device may become inoperable or have a reduced lifetime.

Parameter	Maximum Rating	Unit
Collector Positive Bias Voltage (VC, VC1, VC2)	7	V
Current Mirror Positive Bias Current (Ib, Ib1+Ib2)	8	mA
Current Mirror Positive Bias Voltage (VB, VB1, VB2)	7	V
Maximum Operating Temperature	85	°C
Maximum Storage Temperature	150	°C
Max Junction Temperature for MTTF > 1E6 Hours	125	°C
Minimum Operating Temperature	-40	°C
Minimum Storage Temperature	-65	°C
Output Load VSWR	7	-
Positive Bias Current (Ic1)	90	mA
Positive Bias Current (Ic2)	90	mA
RF Input Power	5	dBm
$\theta_{JC}$	53	°C/W

### Package Information

Parameter	Details	Rating
Dimensions	-	4 x 4 mm
Moisture Sensitivity Level	-	MSL 1

### Recommended Operating Conditions

The Recommended Operating Conditions indicate the limits, inside which the device should be operated, to guarantee the performance given in Electrical Specifications. Operating outside these limits may not necessarily cause damage to the device, but the performance may degrade outside the limits of the electrical specifications. For limits, above which damage may occur, see Absolute Maximum Ratings.

Parameter	Min	Nominal	Max	Unit
Ambient Temperature	-40	25	85	°C
Positive DC Current Mirror Voltage (VB1)	3	5	6	V
Positive DC Current Mirror Current (Ib1)	0.9	2	2.6	mA
Positive DC Current Mirror Voltage (VB2)	3	5	6	V
Positive DC Voltage (VC1)	3	5	6	V
Positive DC Current (Ic1)	8	21	40	mA
Positive DC Voltage (VC2)	3	5	6	V
Positive DC Current Mirror Voltage (Ib2)	0.9	2	2.6	mA
Positive DC Current (Ic2)	8	21	40	mA

Maximum recommended operating current conditions without RF input applied. Please see typical performance plots for relationship between RF input power and DC current draw.

### Sequencing Requirements

There is no sequencing required to power up or power down the amplifier.

Amplifier must have an output load connected when operating with a VC1, or VC2 voltage larger than +5V.

### Electrical Specifications

The electrical specifications apply at TA=+25°C in a 50Ω system. All Specifications and performance shown with VC1 = VC2 and VB1 = VB2

Parameter	Test Conditions	Minimum Frequency (GHz)	Maximum Frequency (GHz)	Min	Typ	Max	Unit
Collector Current, Ic <sup>1</sup>	5V/4V	-	-	-	27	-	mA
Collector Current, Ic <sup>2</sup>	5V/5V	-	-	-	43	-	mA
Collector Current, Ic <sup>3</sup>	5V/6V	-	-	-	67	-	mA
Current Mirror Current, Ib	5V/4V	-	-	-	2.9	-	mA
Current Mirror Current, Ib	5V/5V	-	-	-	4	-	mA
Current Mirror Current, Ib	5V/6V	-	-	-	5.2	-	mA
Frequency	-	-	-	2	-	30	GHz
Input IP3	5V/5V bias, -25 dBm Input Power	2	29	-	-2	-	dBm
Input Power for Saturation	5V/5V bias	2	29	-	4	-	dBm
Input Return Loss	5V/5V bias, -25 dBm Input Power	2	20	-	14	-	dB
Input Return Loss	5V/5V bias, -25 dBm Input Power	20	29	-	7	-	dB
Noise Figure	5V/5V bias, -25 dBm Input Power	2	26.5	-	6	-	dB
Output IP3	5V/5V bias, -25 dBm Input Power	2	29	-	20	-	dBm
Output P1dB	5V/5V bias	2	20	-	19	-	dBm
Output P1dB	5V/5V bias	20	29	-	15	-	dBm
Output Power	5V/5V bias, +6 dBm Input Power	2	20	18	21	-	dBm
Output Power	5V/5V bias, +6 dBm Input Power	20	29	-	18	-	dBm
Output Return Loss	5V/5V bias, -25 dBm Input Power	2	20	-	16	-	dB
Output Return Loss	5V/5V bias, -25 dBm Input Power	20	29	-	11	-	dB
Phase Noise @ 10 kHz Offset	5V/5V bias, +9 dBm Input power, 4 GHz	2	20	-	-165	-	dBc/Hz
Reverse Isolation	5V/5V bias, -25 dBm Input Power	2	29	-	62	-	dB
Small Signal Gain	5V/5V bias, -25 dBm Input Power	20	29	-	18	-	dB
Small Signal Gain	5V/5V bias, -25 dBm Input Power	2	20	18	22	-	dB

[1][2][3] Bias conditions for Ic and Ib tested with no RF input power. See typical performance plots for DC current vs. RF power. Bias conditions presented as VC/VB.

### Typical Performance Plots

Surface mount performance plots are taken in the EVAL-APM-6848 connectorized fixture, and include launch, line, and connector insertion losses.

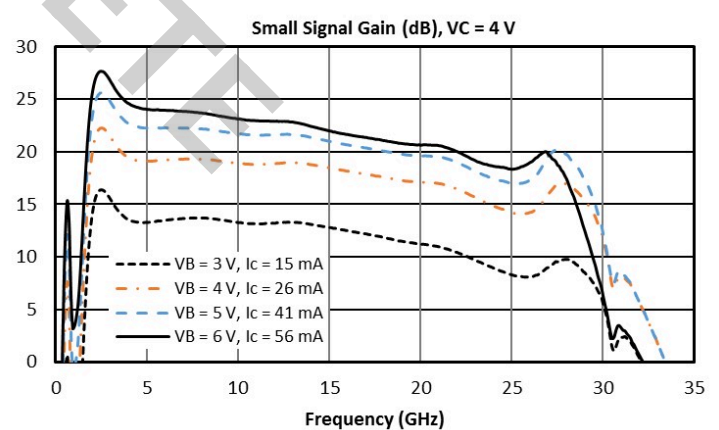
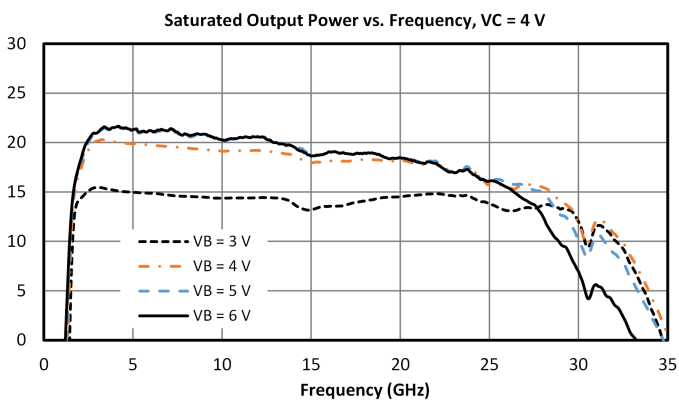
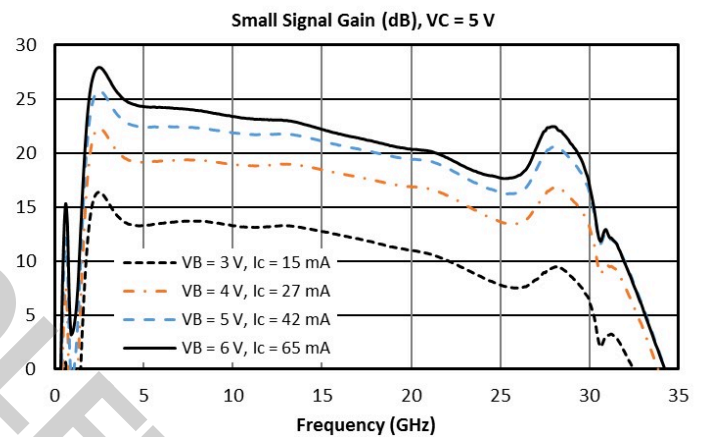
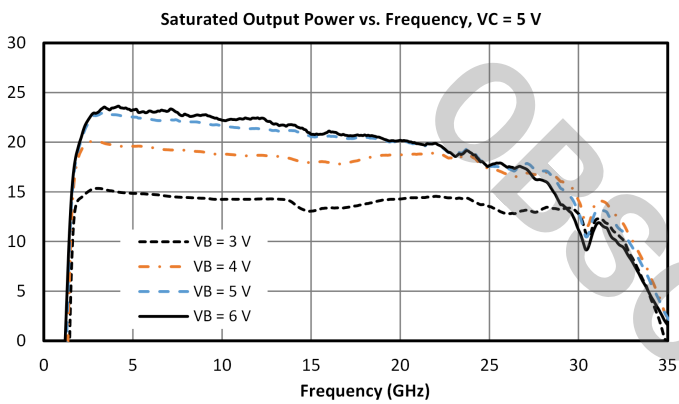
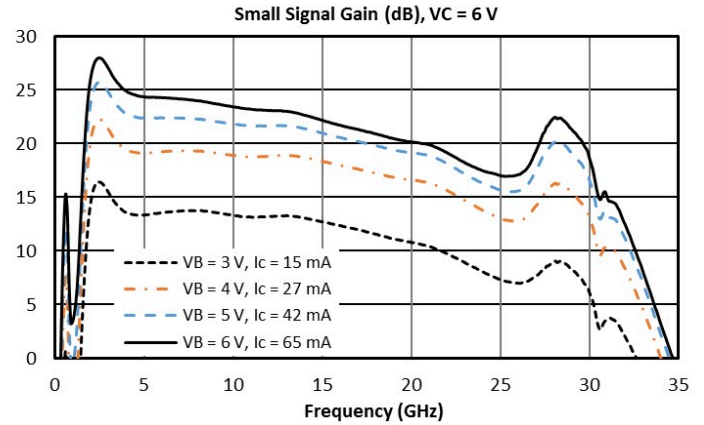
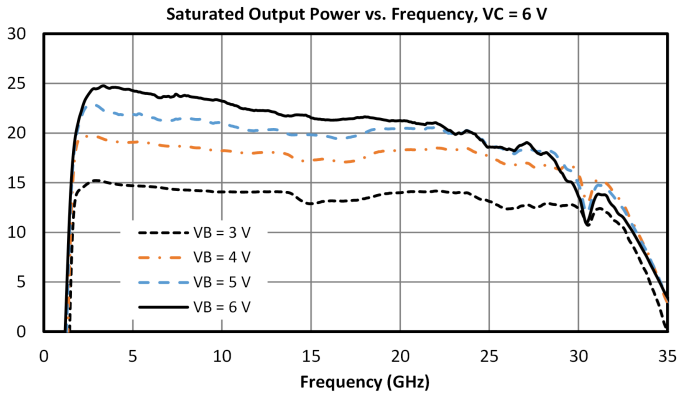

# APM-6848SM

## 2-30 GHz Surface Mount Low Phase Noise Amplifier

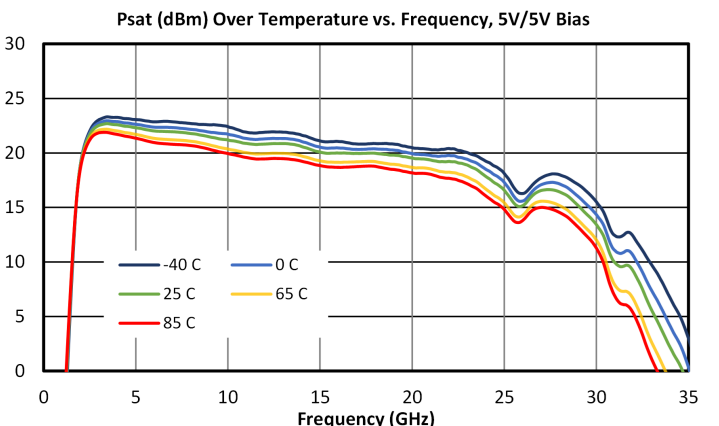
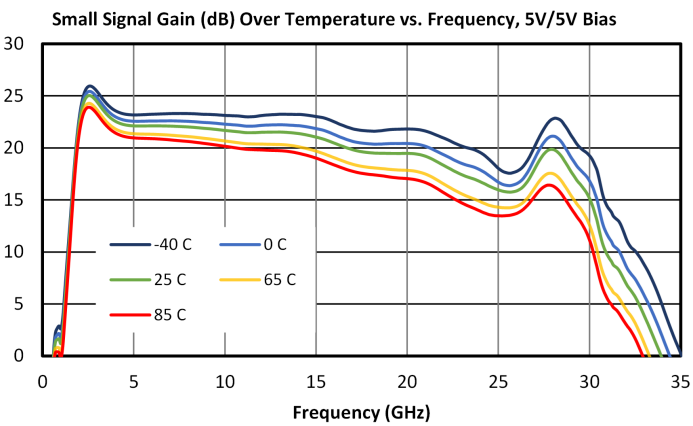
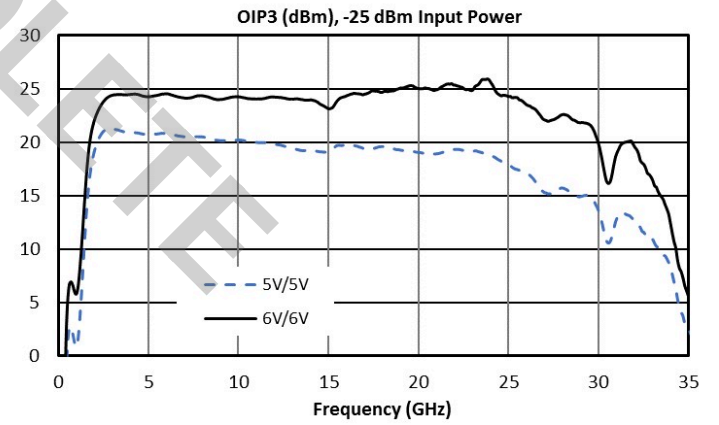
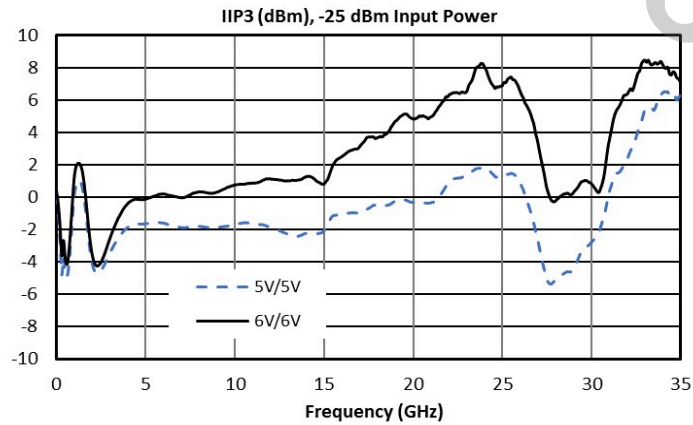
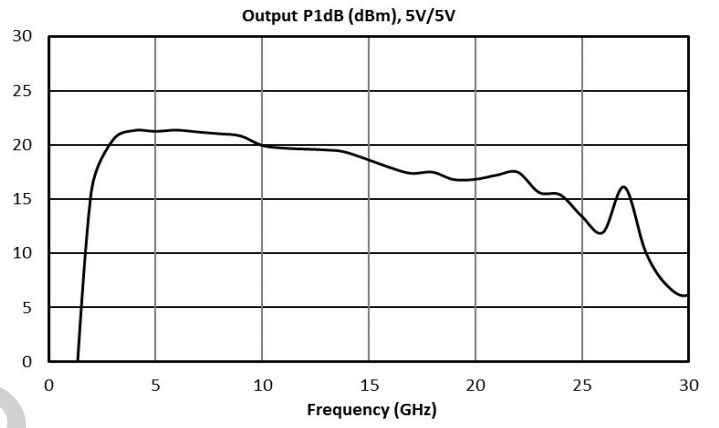
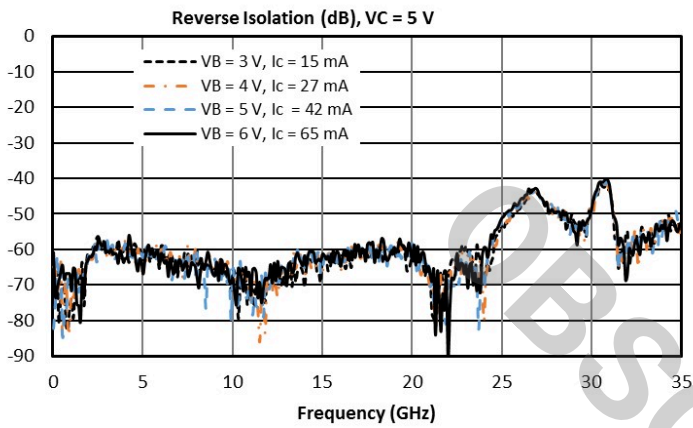
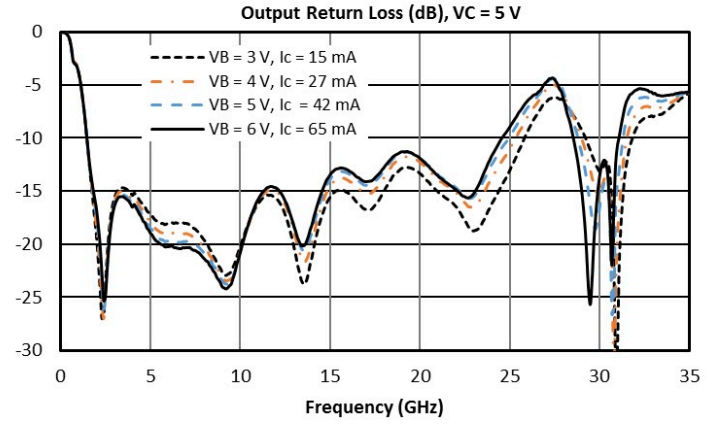
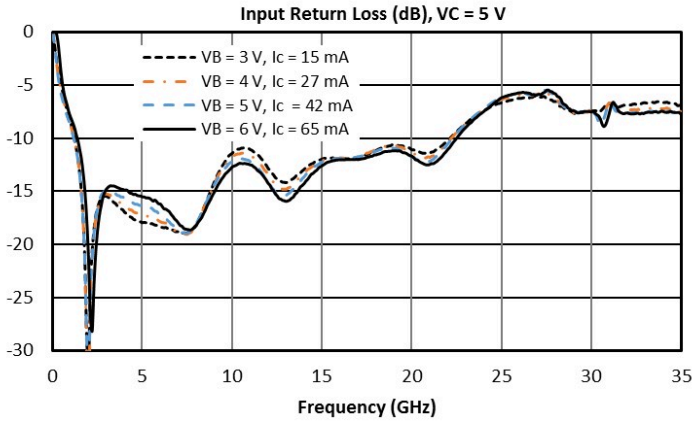

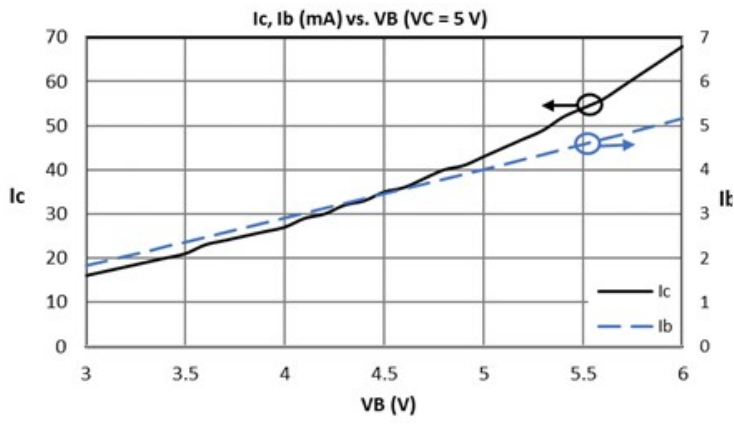

OBSOLETE

## APM-6848SM

2-30 GHz Surface Mount Low Phase Noise Amplifier

### Time Domain Plots

Fast rise time is desirable for linear T3 mixer operation.

5 GHz, +5 dBm In, 5V/5V bias

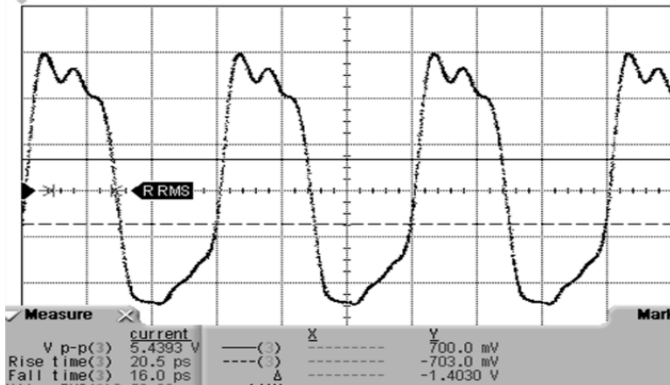

10 GHz, +5 dBm In, 5V/5V bias

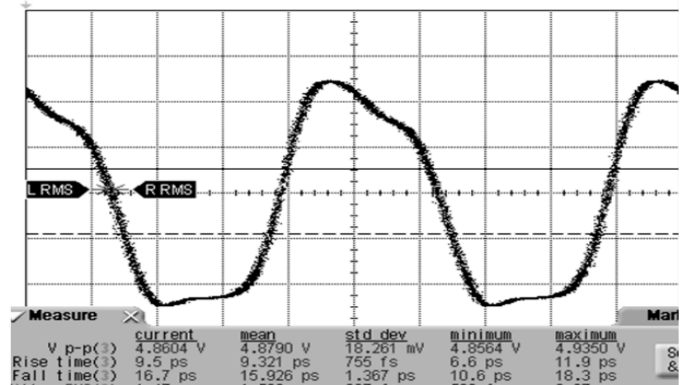

OBSOLETE

### Conversion Loss of Marki Mixers Using APM-6848SM as LO Driver

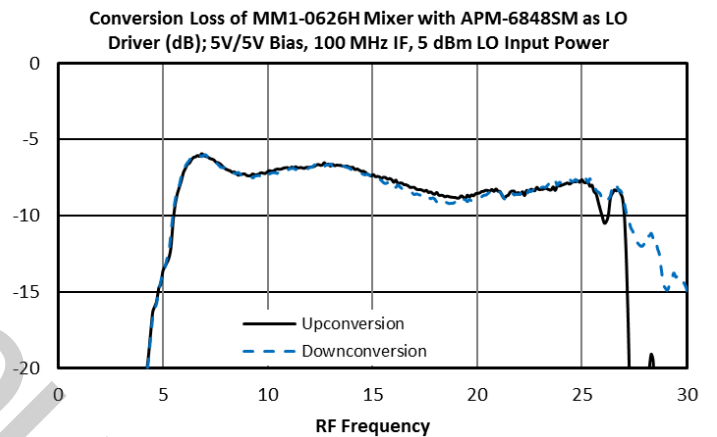
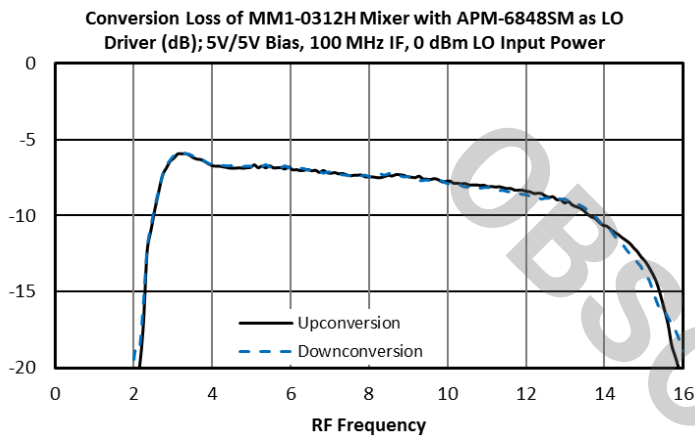
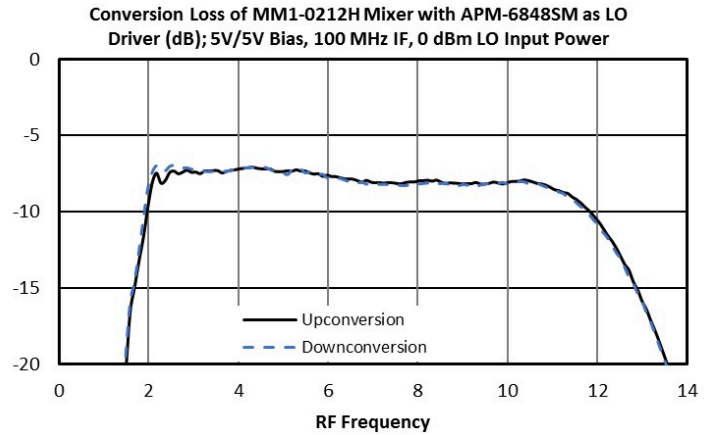
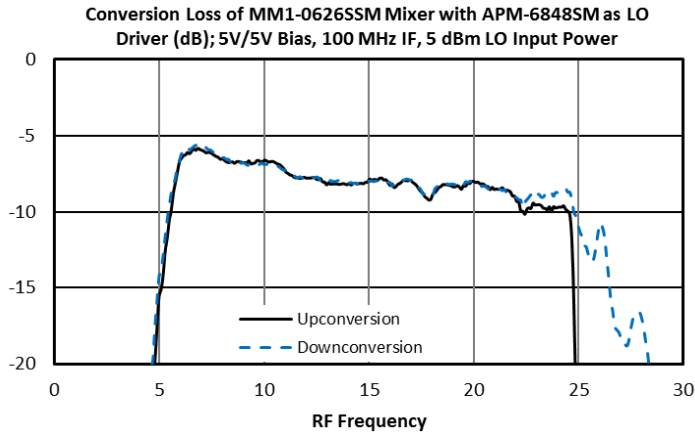

## APM-6848SM

2-30 GHz Surface Mount Low Phase Noise Amplifier

### Application Information

Below are the recommended application circuits for the APM-6848SM.

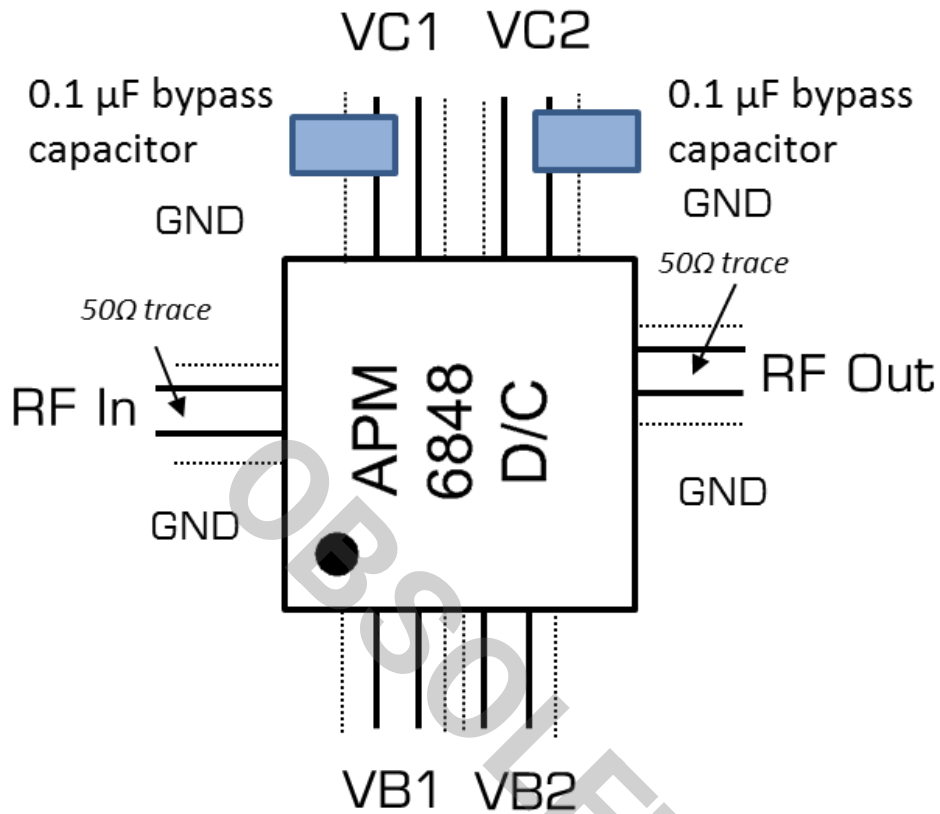

## APM-6848SM

### 2-30 GHz Surface Mount Low Phase Noise Amplifier

RF input and output should be soldered to 50  $\Omega$  traces. Since this is a 2-stage amplifier, VC and VB lines may be biased separately at different voltages for improved efficiency (application circuit shown above), or they may be combined for convenience (below). If combined, feedback oscillations can form along the VC supply lines unless sufficient bypass capacitance to ground is used.

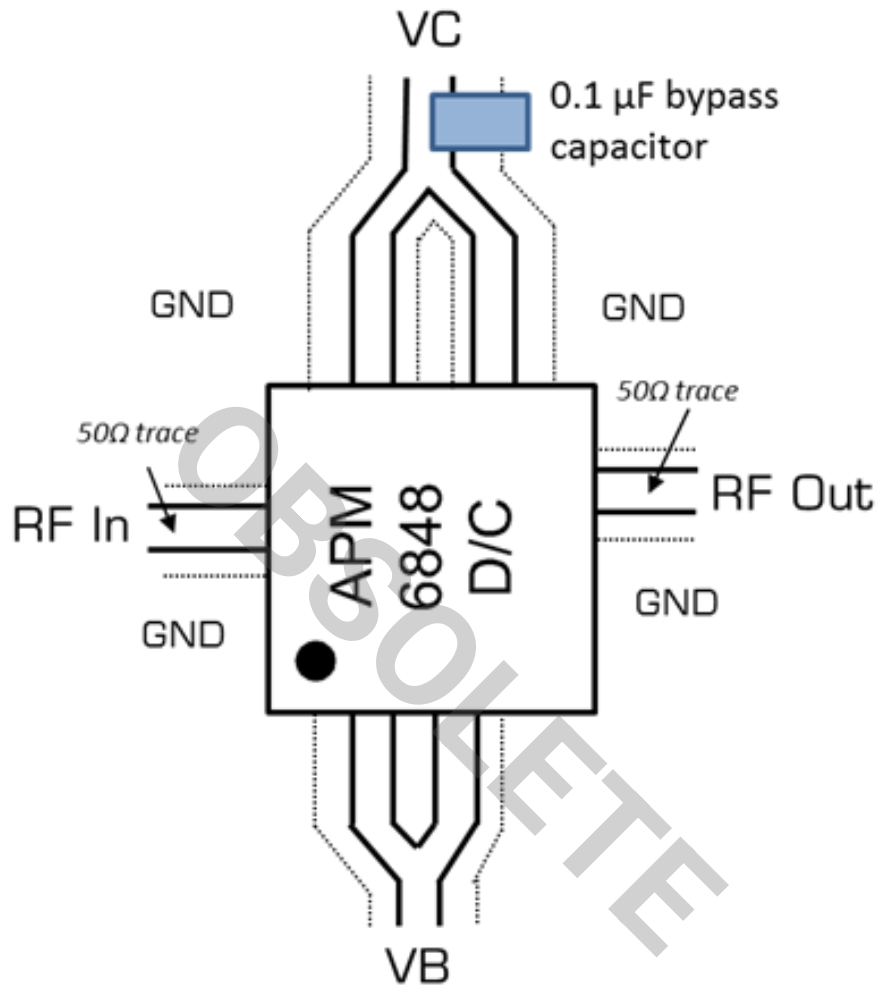

#### Gain and Power Control

The APM-6848 is a 2-stage amplifier integrated on a single IC. In the APM-6848SM package, the user has some freedom to operate the 2 amplifier stages independently for their application-specific needs. Please refer to Port Functions to see the function of each port on the APM-6848SM, and refer to the gain and Psat plots in Typical Performance Plots to see how bandwidth, saturated output power, and gain profile change for various bias conditions.

Generally, the gain of the first stage and second stage of the amplifier can be controlled by adjusting VB1 and VB2 respectively. Increasing the voltage applied to a VB pad increases the current drawn into the corresponding amplifier stage, which strongly correlates to the gain of that stage, and some difference to the output power of that stage. Increasing the voltage on a VC pad generally increases the linearity, maximum output power, and DC power consumption of the corresponding amplifier stage.

In the case where a user wants to drive the LO port of a mixer from an initial LO power of +5 dBm at 10 GHz, the user could apply 5V at all 4 DC ports and see an output power of +21.5 dBm and an overall power consumption of about 1 watt (the amplifier stages pull more DC current as the gain compresses in a high input power condition). Alternatively, the user could apply 3.5 V – 4 V to VB1 and VC1, and 6V to VB2 and VC2 and see an output power of 22.5 dBm with very little difference in the overall power consumption. For applications with a strict power budget and performance requirements, optimizing the bias conditions of the amplifier can be a useful tool for the system designer.

OBSELETE

## APM-6848SM

2-30 GHz Surface Mount Low Phase Noise Amplifier

### Mechanical Data

### Outline Drawing

Download : [Outline 2D Drawing](#) | [Outline 3D Drawing](#) | [Outline 3D STP](#)

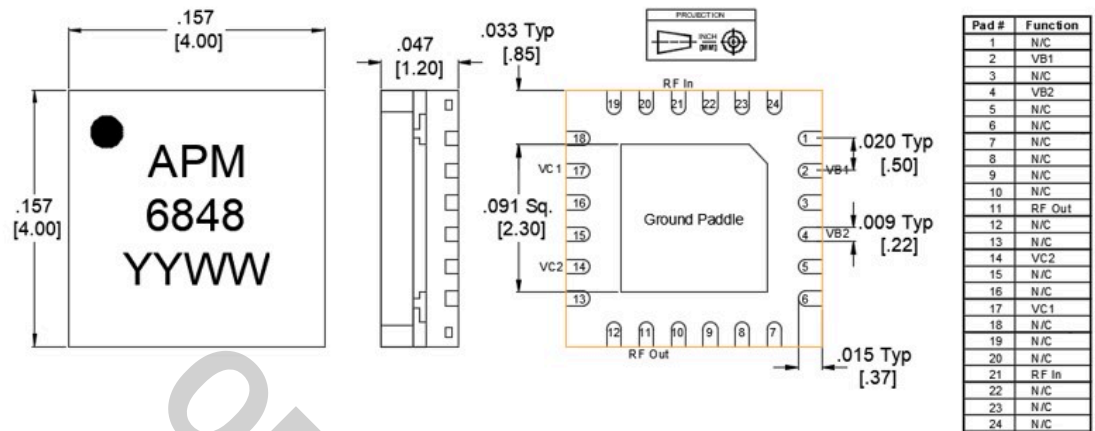

### Notes:

1. Substrate material is Plastic.
2. I/O Leads and Die Paddle are 0.05  $\mu\text{m}$  Au over 0.02  $\mu\text{m}$  Pd over 0.5  $\mu\text{m}$  Ni.
3. All unconnected pins should be connected to PCB RF ground.

## APM-6848SM

2-30 GHz Surface Mount Low Phase Noise  
Amplifier

### Footprint Image

Download : [Footprint Drawing](#)

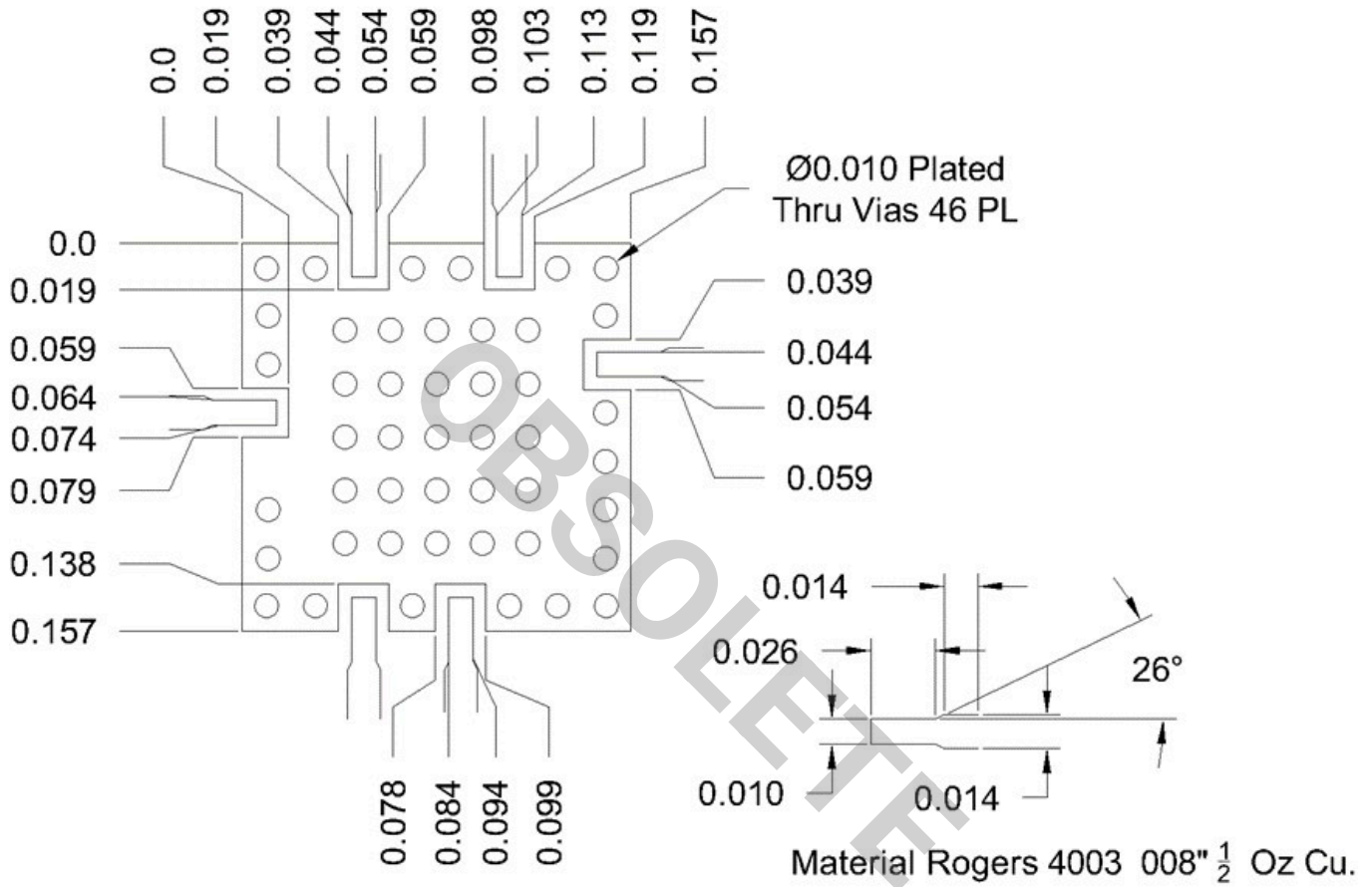

**DISCLAIMER**

MARKI MICROWAVE, INC., ("MARKI") PROVIDES TECHNICAL SPECIFICATIONS AND DATA (INCLUDING DATASHEETS), APPLICATION OR OTHER DESIGN ADVICE, WEB TOOLS, AND OTHER INFORMATION AND RESOURCES "AS IS" AND WITH ALL FAULTS. MARKI DISCLAIMS ALL WARRANTIES, EXPRESS OR IMPLIED, INCLUDING, WITHOUT LIMITATION, ANY IMPLIED WARRANTIES OF MERCHANTABILITY, FITNESS FOR A PARTICULAR PURPOSE, OR NON-INFRINGEMENT. These resources are intended for developers skilled in the art designing with Marki products. You are solely responsible for (1) selecting the appropriate products for your application, (2) designing, validating, and testing your application, and (3) ensuring your application meets applicable standards and other requirements. Marki makes no guarantee regarding the suitability of its products for any particular purpose, nor does Marki assume any liability whatsoever arising out of your use or application of any Marki product.

Marki grants you permission to use these resources only for development of an application that uses Marki products. Other reproduction or use of these resources is strictly prohibited. No license is granted to any other Marki intellectual property or to any third-party intellectual property. Marki reserves the right to make changes to the product(s) or information contained herein without notice.

MARKI MICROWAVE and T3 MIXER are trademarks or registered trademarks of Marki Microwave, Inc. All other trademarks used are the property of their respective owners.

© 2019 - 2020, Marki Microwave, Inc

OBSOLETE