

# AMM-7473PC

## 0.4 – 26.5 GHz GaAs MMIC Amplifier

### DEVICE OVERVIEW

#### General Description

The AMM-7473PC is a high-linearity broadband MMIC amplifier capable of providing +25 dBm output power typical. The AMM-7473PC can serve either as a linear signal amplifier, or as a saturated driver amplifier for H- or S-diode mixers. The amplifier has excellent return losses, gain flatness, and IP3.

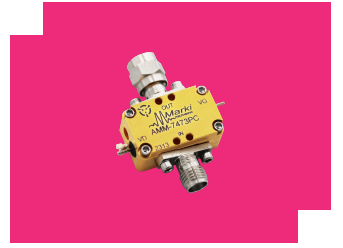

[Download s-parameters here](#)

#### Features

- +25 dBm output power up to 15GHz
- 16 dB gain up to 15GHz
- Excellent Return Losses
- No external bias tee required

#### Applications

- Mobile test and measurement equipment
- Radar and satellite communications
- Driver Amplifier for H and S - Diode Mixers

#### Functional Block Diagram

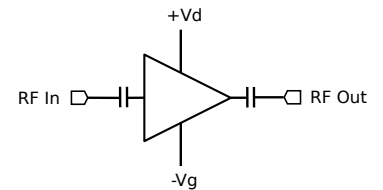

#### Part Ordering Options

Part Number	Description	Package	Connectors	Green Status	Product Lifecycle	Export Classification
AMM-7473PC	0.4 – 26.5 GHz GaAs MMIC Amplifier	PC	<u>Standard</u>	REACH RoHS	Released	EAR99

## Table Of Contents

- **Device Overview**
  - General Description
  - Features
  - Applications
  - Functional Block Diagram
- **Port Configuration and Functions**
  - Port Diagram
  - Port Functions
- **Revision History**
- **Specifications**
  - Absolute Maximum Ratings
  - Fit and MTTF Table
  - Package Information
  - Recommended Operating Conditions
  - Sequencing Requirements
  - Electrical Specifications
  - Typical Performance Plots
- **Mechanical Data**
  - Outline Drawing

## Revision History

Revision Code	Revision Date	Comment
-	2023-04-01	Datasheet Initial Release
A	2026-02-13	MTTF Table Added.



## Port Configuration and Functions

### Port Diagram

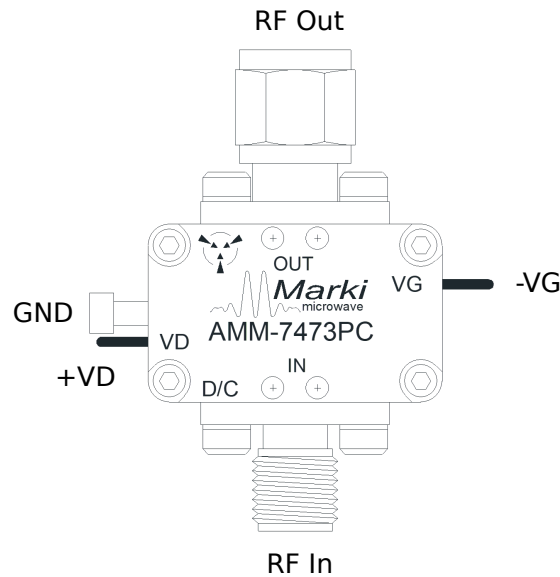
A port diagram of the AMM-7473PC is shown below.

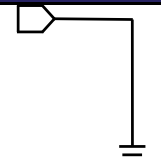
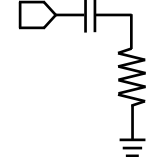
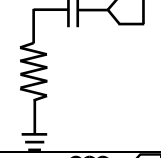
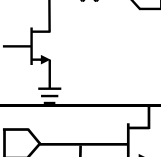

### Port Functions

Port	Function	Connector Type	Description	DC Equivalent Circuit
GND	Ground	-	Housing or ground lug must be connected to a DC/RF ground potential with high thermal and electrical conductivity.	
RF In	RF Input	SMAF	This is the RF Input port of the amplifier die. It is RF matched to 50 Ω and has built-in DC blocking capacitors.	
RF Out	RF Output	SMAM	This is the amplifier's RF Output. It is RF matched to 50 Ω and has built-in DC blocking capacitors. Must have less than 7:1 VSWR when operating.	
Vd	Drain Supply Pin	-	The VD pin supplies DC voltage to the drain of the amplifier IC. Apply gate bias voltage Vg before applying drain power supply.	
Vg	Gate Bias Pin	-	The VG pin provides a required negative bias which controls the drain power supply current to the amplifier. More negative voltage decreases the supply current. Apply gate bias voltage Vg before applying drain power supply.	

## Specifications

### Absolute Maximum Ratings

The Absolute Maximum Ratings indicate limits beyond which damage may occur to the device. If these limits are exceeded, the device may become inoperable or have a reduced lifetime. Reliability limits are individual, instantaneous catastrophic limits only. Functional operation limits are indicated below. Operation of the device at multiple absolute maximum limits or for extended periods at a single limit can cause degradation and damage to the device.

Parameter	Maximum Rating	Unit
Drain Current (RF Applied)	550	mA
Drain Supply Voltage	10	V
Gate Bias Voltage	0.5	V
Maximum Operating Temperature for MTTF > 1E6 hours	85	°C
Maximum Storage Temperature	150	°C
Minimum Operating Temperature for MTTF > 1E6 hours	-55	°C
Minimum Storage Temperature	-65	°C
RF Input Power	18	dBm

### FIT and MTTF Table

T (°C)	$\lambda$ (TIF)	MTTF (hr)	MTTF (yr)
105	2,441.45	4.10E+05	47
85	310.48	3.22E+06	368
55	8.79	1.14E+08	12,992
25	0.12	8.24E+09	941,063

### Package Information

Parameter	Details	Rating
Weight	Package name: PC	11g
Dimensions	-	21.85 x 13.21 mm

### Recommended Operating Conditions

The Recommended Operating Conditions indicate the limits, inside which the device should be operated, to guarantee the performance given in Electrical Specifications. Operating outside these limits may not necessarily cause damage to the device, but the performance may degrade outside the limits of the electrical specifications. For limits, above which damage may occur, see Absolute Maximum Ratings.

Parameter	Min	Nominal	Max	Unit
Ambient Temperature	-40	25	85	°C
Power Supply DC Voltage	5	7	7.5	V
Power Supply DC Current (Id) (No RF Input) <sup>1</sup>	100	150	175	mA
Input Power for Saturation	11	15	16	dBm

<sup>[1]</sup> Recommended operating current conditions without RF input applied.

### Sequencing Requirements

Turn-on Procedure if required biases are unknown:

1. Apply -1 V to Vg.
2. Apply desired Vd.
3. Increase Vg voltage towards -0.5 V until Id = 150 mA.
4. Apply RF input power.

Turn-on Procedure if required biases are known:

1. Apply desired Vg (previously determined to produce 150 mA Idq).
2. Apply desired Vd.
3. Apply RF input power.

Turn-off Procedure:

1. Turn off RF input power.

**Electrical Specifications**

Unless otherwise specified, electrical specifications apply at TA=+25°C, Vd = 7V, Idq = 150mA (where Idq is the drain current with no RF applied). Vg is set as required to achieve Idq = 150mA in a 50Ω system. Min and Max limits apply only to our connectorized units and are guaranteed at TA=+25°C

Parameter	Test Conditions	Minimum Frequency (GHz)	Maximum Frequency (GHz)	Min	Typ	Max	Unit
Output P1dB	Vd = 7V/150mA Bias	5	25	-	18	-	dBm
Current Consumption	Vd = 7V, no RF input	-	-	-	150	-	mA
Input IP3	Vd = 7V, Pin = -15 dBm per tone, 10 MHz tone spacing	0.4	26.5	-	16	-	dBm
Input Power for Saturation	Vd = 7V	0.4	26.5	11	15	-	dBm
Input Return Loss	Vd = 7V, Pin = -20 dBm	0.4	26.5	-	10	-	dB
Noise Figure	Vd = 7V, Pin = -20 dBm	10	26.5	-	3.9	-	dB
Noise Figure	Vd = 7V, Pin = -20 dBm	2	5	-	3.4	-	dB
Noise Figure	Vd = 7V, Pin = -20 dBm	5	10	-	2.3	-	dB
Output IP3	Vd = 7V, Pin = -15 dBm per tone, 10 MHz tone spacing	0.4	26.5	-	34	-	dBm
Output Return Loss	Vd = 7V, Pin = -20 dBm	0.4	26.5	-	15	-	dB
Reverse Isolation	Vd = 7V, Pin = -20 dBm	0.4	26.5	-	40	-	dB
Saturated Output Power	Vd = 7V	0.4	15	23	25	-	dBm
Saturated Output Power	Vd = 7V	15	26.5	18	21	-	dBm
Small Signal Gain	Vd = 7V, Pin = -20 dBm	0.4	15	14	16	-	dB
Small Signal Gain	Vd = 7V, Pin = -20 dBm	15	26.5	11	13	-	dB

**Typical Performance Plots**

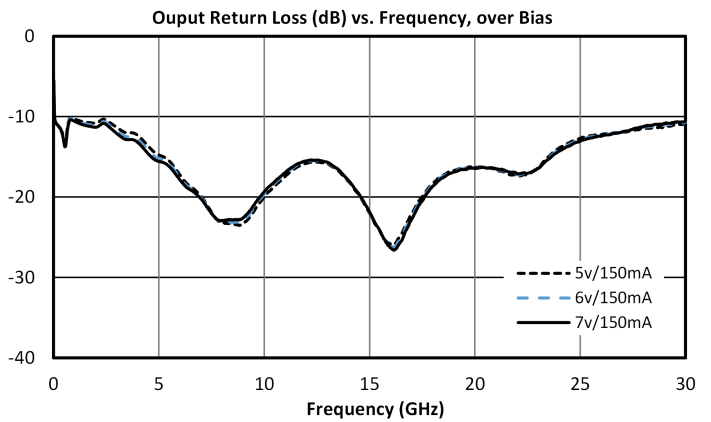
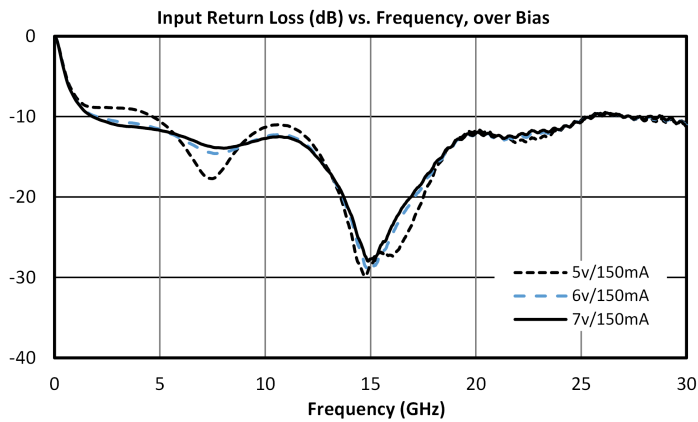
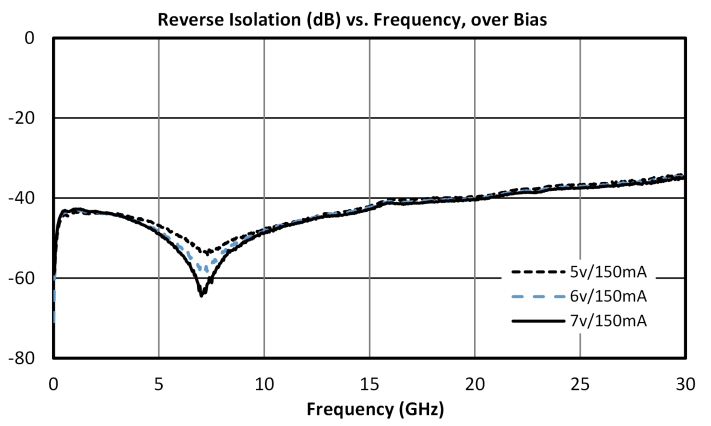
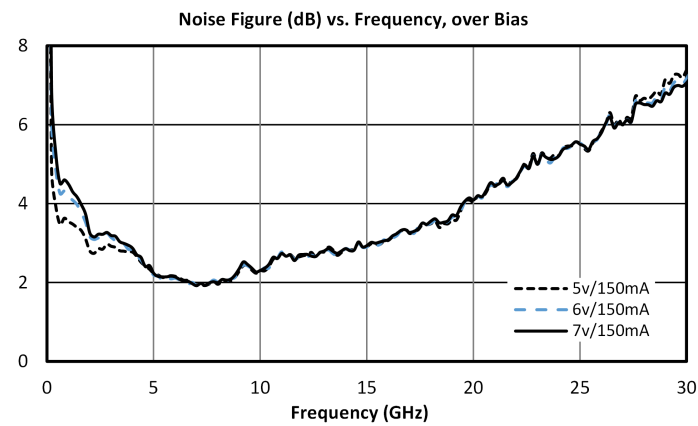
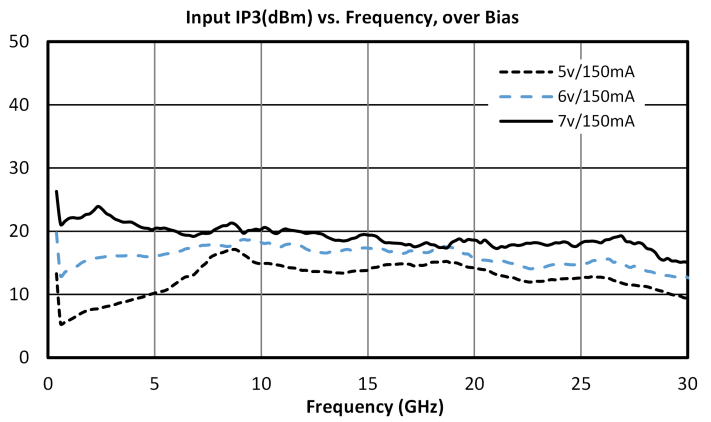
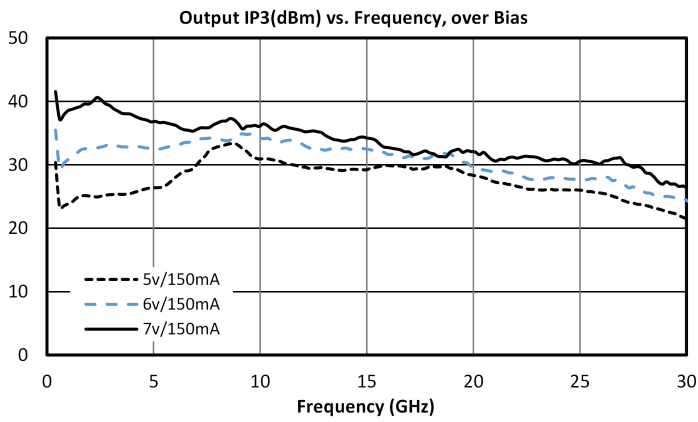
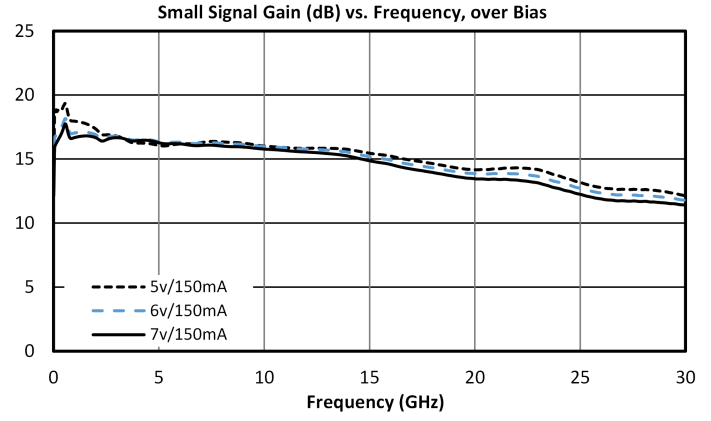
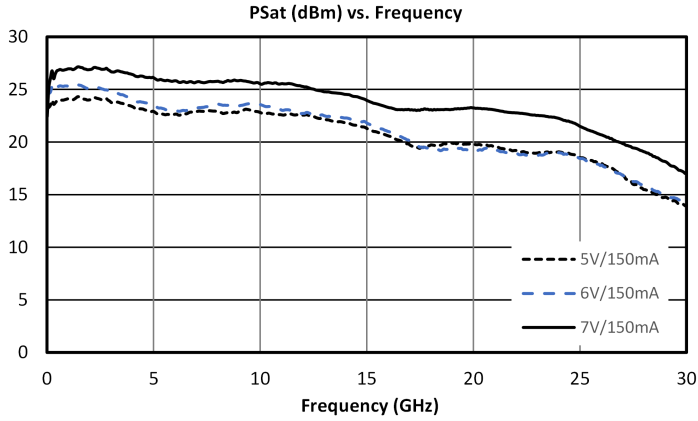

**Output Power (dBm) vs RF Input Power**  
**7V/150mA Bias, over Frequency**

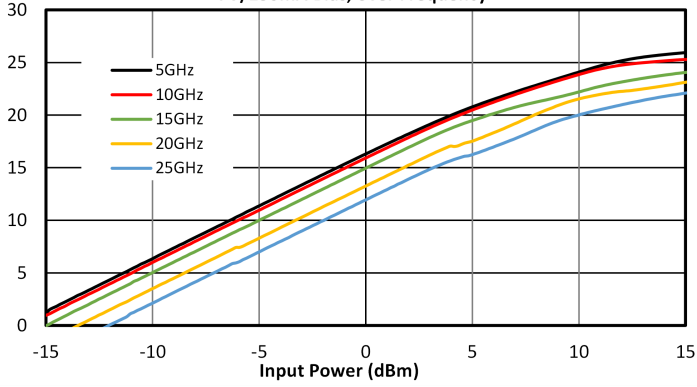

**Id (A) vs RF Input Power**  
**7V/150mA Bias, over Frequency**

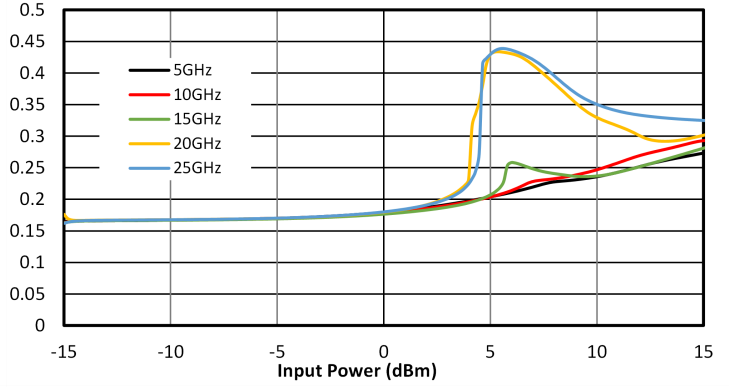

**Output Power (dBm) vs RF Input Power**  
**5V/150mA Bias, over Frequency**

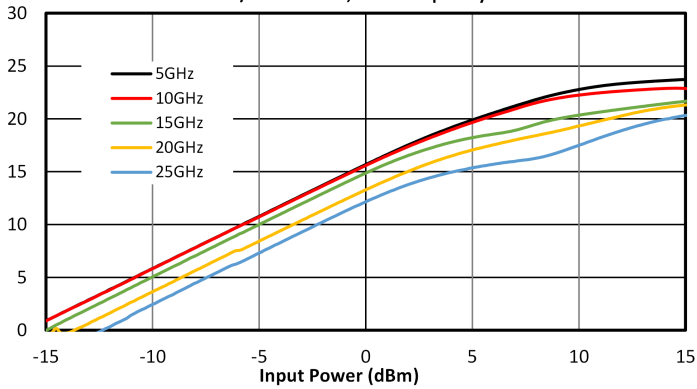

**Id (A) vs RF Input Power**  
**5V/150mA Bias, over Frequency**

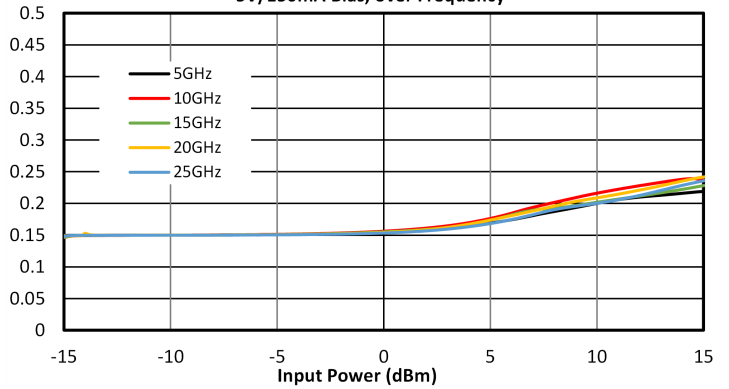

### Mechanical Data

### Outline Drawing

Download : [Outline 3D Drawing](#) | [Outline 3D STP](#)

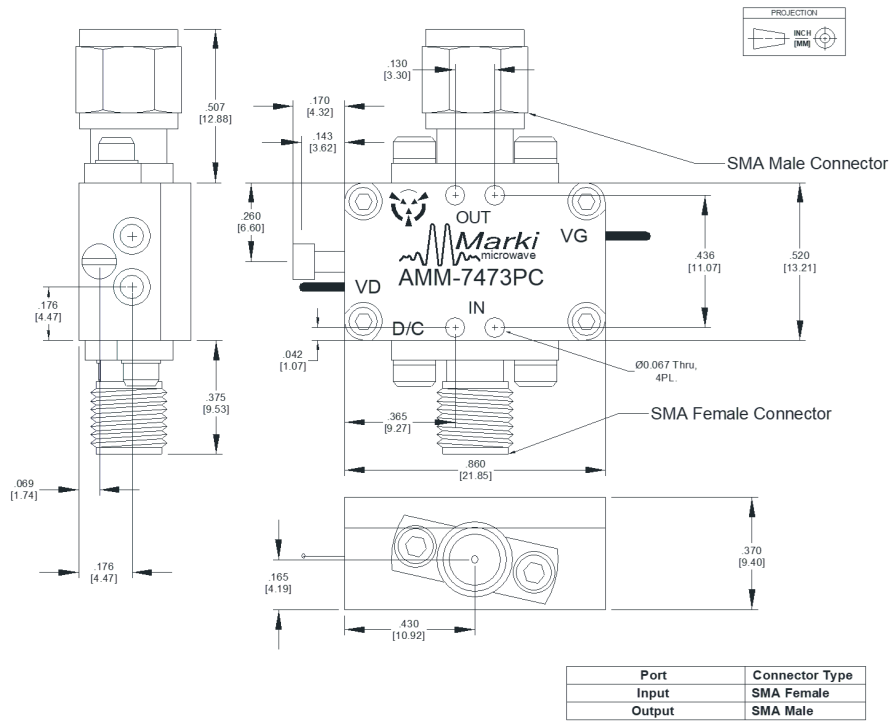

### Package Notes:

- 1) All measurements are typical.
- 2) Ground lug and bias pins are solderable.

**DISCLAIMER**

MARKI MICROWAVE, LLC., (“MARKI”) PROVIDES TECHNICAL SPECIFICATIONS AND DATA (INCLUDING DATASHEETS), APPLICATION OR OTHER DESIGN ADVICE, WEB TOOLS, AND OTHER INFORMATION AND RESOURCES “AS IS” AND WITH ALL FAULTS. MARKI DISCLAIMS ALL WARRANTIES, EXPRESS OR IMPLIED, INCLUDING, WITHOUT LIMITATION, ANY IMPLIED WARRANTIES OF MERCHANTABILITY, FITNESS FOR A PARTICULAR PURPOSE, OR NON-INFRINGEMENT.

These resources are intended for developers skilled in the art designing with Marki products. You are solely responsible for (1) selecting the appropriate products for your application, (2) designing, validating, and testing your application, and (3) ensuring your application meets applicable standards and other requirements. Marki makes no guarantee regarding the suitability of its products for any particular purpose, nor does Marki assume any liability whatsoever arising out of your use or application of any Marki product.

Marki grants you permission to use these resources only for development of an application that uses Marki products. Other reproduction or use of these resources is strictly prohibited. No license is granted to any other Marki intellectual property or to any third-party intellectual property. Marki reserves the right to make changes to the product(s) or information contained herein without notice.

MARKI MICROWAVE and T3 MIXER are trademarks or registered trademarks of Marki Microwave, LLC. All other trademarks used are the property of their respective owners.

© 2023, 2026, Marki Microwave, LLC