

MM2-0530HSM-2

GaAs MMIC Triple Balanced Mixer

DEVICE OVERVIEW

General Description

The MM2-0530HSM is a passive MMIC triple balanced mixer. It features a broadband IF port that spans from 2 to 20 GHz, and has excellent spurious suppression. GaAs MMIC technology improves upon the previous generation of hand assembled, hybrid M2 triple balanced mixers with improved isolations, unit-to-unit repeatability and reliability. The MM2-0530HSM is 4x4 mm QFN packaged. Evaluation boards are available.

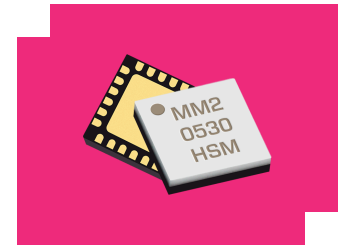

Features

- Broadband IF Port
- Typical Input 1 dB Compression of +15 dBm
- High Input IP3 of +21 dBm
- Excellent LO to RF Isolation
- Unit-to-Unit Repeatability
- RoHS Compliant

Applications

N/A

Functional Block Diagram



Part Ordering Options

| Part Number | Description | Package | Packing Size | Green Status | Product Lifecycle | Export Classification |
|----------------|--|---------|--------------|---------------|-------------------|-----------------------|
| MM2-0530HSM-2 | GaAs MMIC Triple Balanced Mixer | QFN | - | REACH RoHS | Released | EAR99 |
| EVAL-MM2-0530H | Evaluation Board, GaAs MMIC 5 - 30 GHz Triple Balanced Mixer | EVAL | - | REACH RoHS | Released | EAR99 |
| MM2-0530H-2-TR | Tape and Reel, GaAs MMIC Triple Balanced Mixer | QFN | 7" | REACH RoHS | Released | EAR99 |

Table Of Contents

■ Device Overview

- General Description
- Features
- Applications
- Functional Block Diagram

■ Port Configuration and Functions

- Port Diagram
- Port Functions

■ Specifications

- Absolute Maximum Ratings
- Package Information
- Recommended Operating Conditions
- Electrical Specifications
- Typical Performance
- Spur Tables

■ Operation

- Application Circuit
- Application Circuit Description

■ Footprint Image

■ Evaluation Board

Port Configuration and Functions

Port Diagram

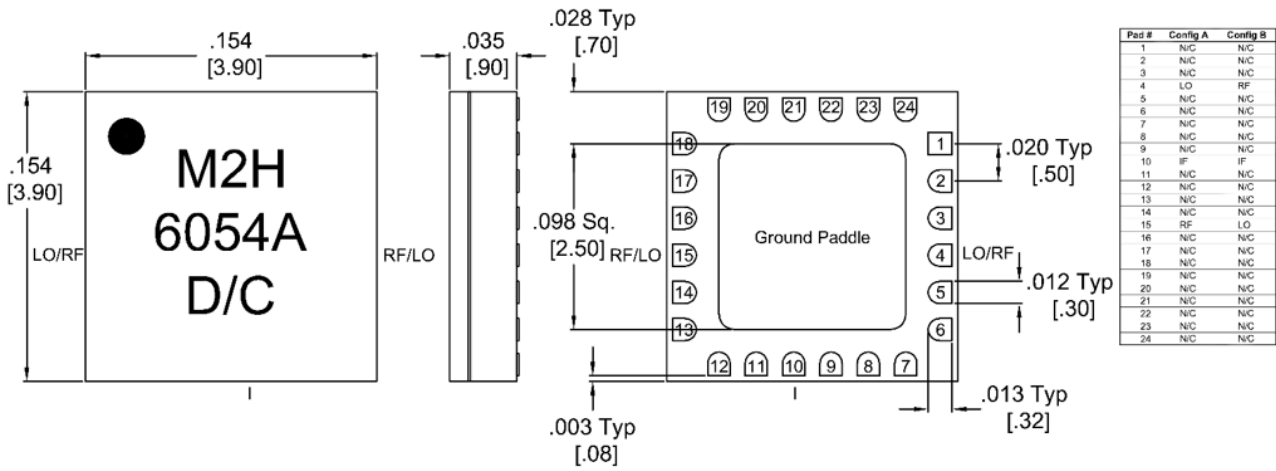

Outline Drawing – 4mm QFN package

1. Substrate material is Ceramic.
2. I/O leads and Die Paddle are: Ni: 8.89um MAX 1.27um MIN. Pd : 0.17um MAX 0.07um MIN. Au : 0.254um MAX 0.03um MIN
3. All unconnected pads should be connected to PCB RF ground

Port Functions

Configuration A

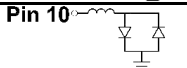
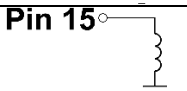
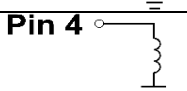
| Port | Function | Description | DC Equivalent Circuit |
|--------|----------|---|---|
| GND | Ground | SM package ground path is provided through the ground paddle. | GND  |
| Pin 10 | IF | Pin 10 is DC coupled to the diodes. Blocking capacitor is optional. | Pin 10  |
| Pin 15 | RF | Pin 15 is DC short and AC matched to 50 Ω from 5 to 30 GHz. Blocking capacitor is optional. | Pin 15  |
| Pin 4 | LO | Pin 4 is DC short and AC matched to 50 Ω from 5 to 30 GHz. Blocking capacitor is optional. | Pin 4  |

Configuration B

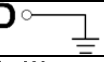
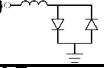
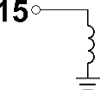
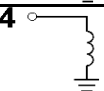
| Port | Function | Description | DC Equivalent Circuit |
|--------|----------|---|---|
| GND | Ground | SM package ground path is provided through the ground paddle. | GND  |
| Pin 10 | IF | Pin 10 is DC coupled to the diodes. Blocking capacitor is optional. | Pin 10  |
| Pin 15 | LO | Pin 15 is DC short and AC matched to 50 Ω from 5 to 30 GHz. Blocking capacitor is optional. | Pin 15  |
| Pin 4 | RF | Pin 4 is DC short and AC matched to 50 Ω from 5 to 30 GHz. Blocking capacitor is optional. | Pin 4  |

Specifications

Absolute Maximum Ratings

| Parameter | Maximum Rating | Unit |
|----------------------------------|----------------|------|
| Maximum Operating Temperature | 100 | °C |
| Maximum Storage Temperature | 125 | °C |
| Minimum Operating Temperature | -55 | °C |
| Minimum Storage Temperature | -65 | °C |
| Pin 10 DC Current | 15 | mA |
| Pin 15 DC Current | 24 | mA |
| Pin 4 DC Current | 21 | mA |
| RF Power Handling (RF+LO), 100°C | 20 | dBm |
| RF Power Handling (RF+LO), 25°C | 28 | dBm |

Package Information

| Parameter | Details | Rating |
|----------------------------|---------|----------|
| Dimensions | - | 4 x 4 mm |
| Moisture Sensitivity Level | - | MSL 1 |

Recommended Operating Conditions

| Parameter | Min | Nominal | Max | Unit |
|----------------|-----|---------|-----|------|
| LO Input Power | 16 | - | 22 | - |

Electrical Specifications

Specifications guaranteed from -55 to +100°C, measured in a 50Ω system. Specifications are shown for Configurations A (B).

| Parameter | Port Configuration | Test Conditions | Min | Typ | Max | Unit |
|------------------------------|--------------------|--|-----|-----|-----|------|
| RF Frequency Range | - | - | 5 | - | 30 | GHz |
| LO Frequency Range | - | - | 5 | - | 30 | GHz |
| IF Frequency Range | - | - | 2 | - | 20 | GHz |
| Conversion Loss ¹ | A | LO/RF=5-30 GHz IF=2-20 GHz LO Drive Level= 20 | - | 8 | - | dB |
| Conversion Loss ² | B | LO/RF=5-30 GHz IF=2-20 GHz LO Drive Level= 20 | - | 9 | - | dB |
| Input IP3 ³ | A | LO/RF=5-30 GHz IF=2-20 GHz LO Drive Level= 16-22 | - | 21 | - | dBm |
| Input IP3 ⁴ | B | LO/RF=5-30 GHz IF=2-20 GHz LO Drive Level= 16-22 | - | 28 | - | dBm |
| Input P1dB | A | LO/RF=5-30 GHz IF=2-20 GHz LO Drive Level= 16-22 | - | 14 | - | dBm |
| Input P1dB | B | LO/RF=5-30 GHz IF=2-20 GHz LO Drive Level= 16-22 | - | 19 | - | dBm |
| LO-RF Isolation | - | - | - | 40 | - | dB |

[1][2] Measured Conversion Loss measured at 3 GHz fixed IF

[3][4] IP3 depends on LO drive conditions, see plots for more details

Typical Performance

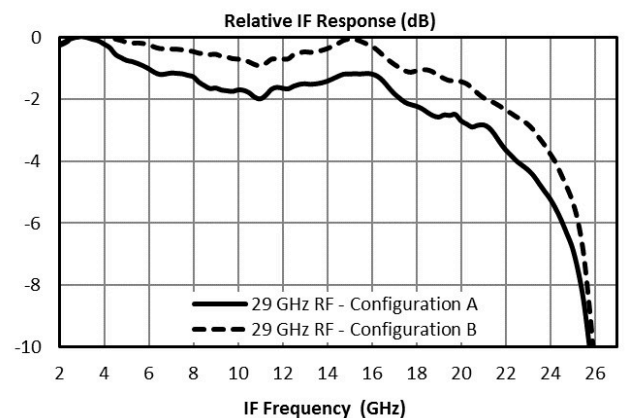
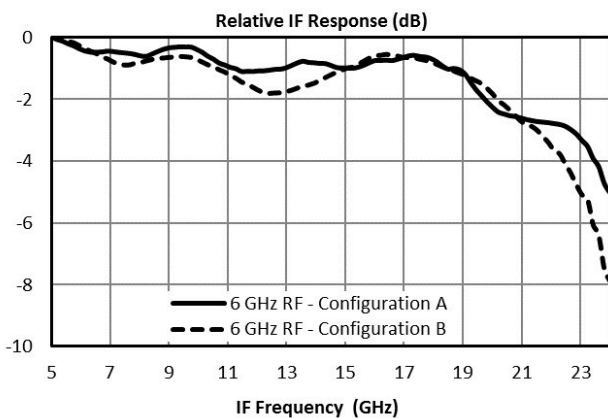
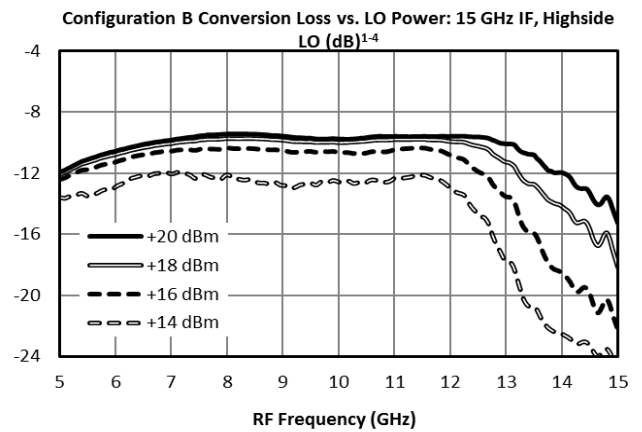
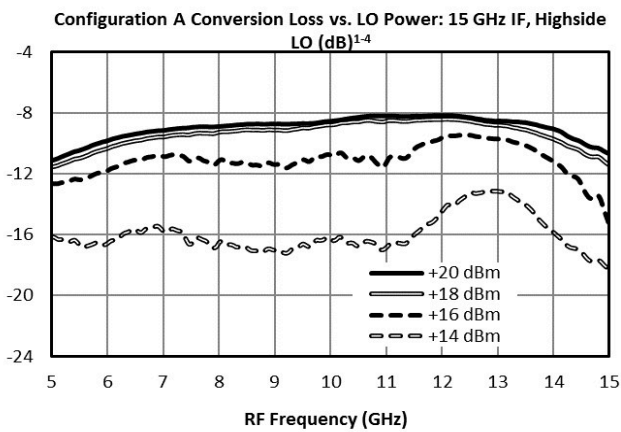
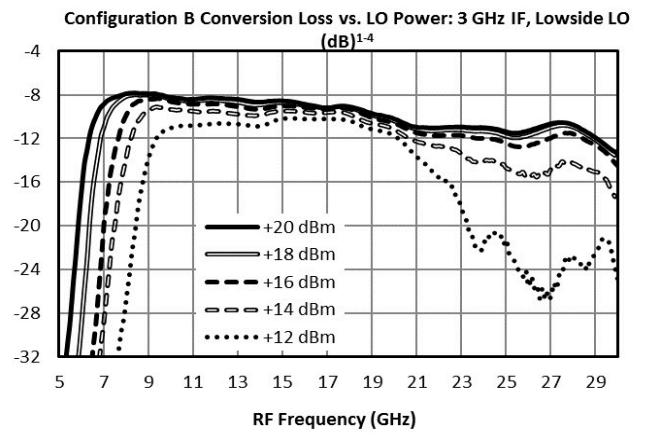
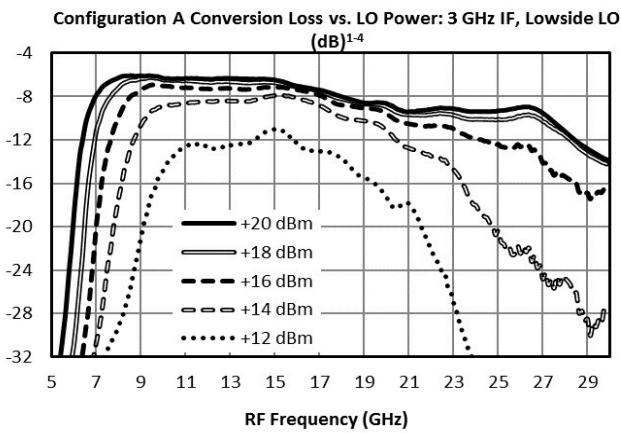
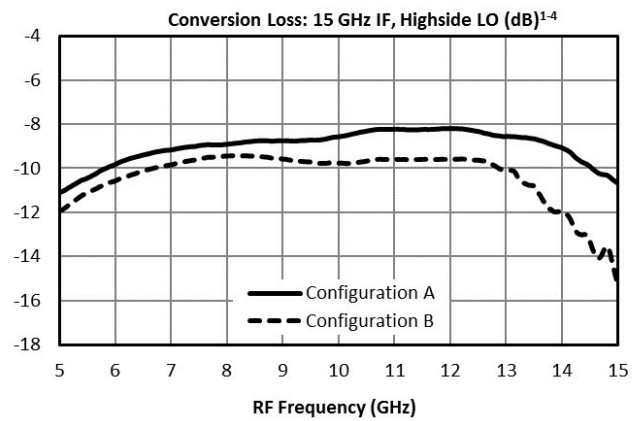
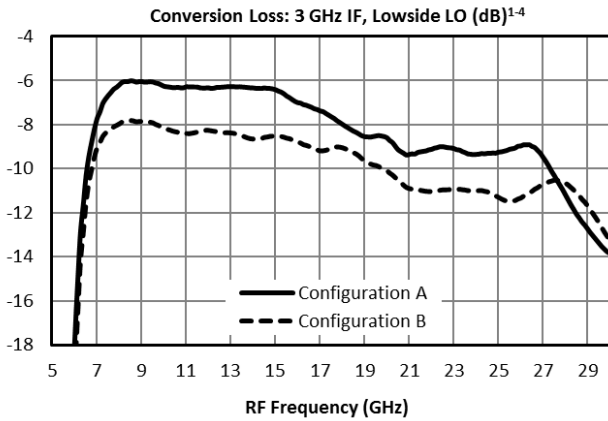

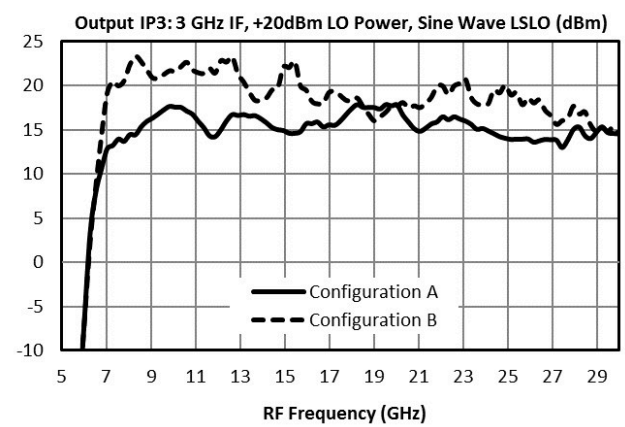
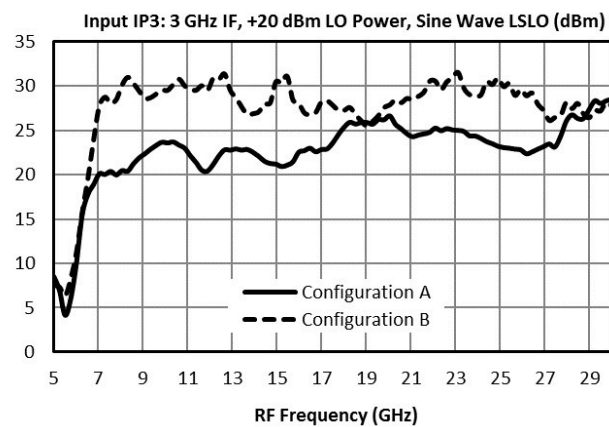
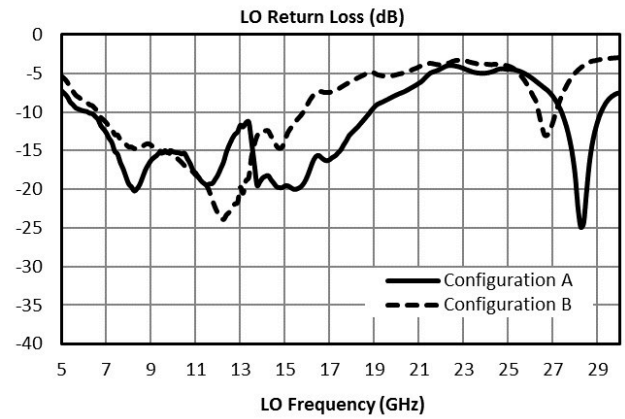
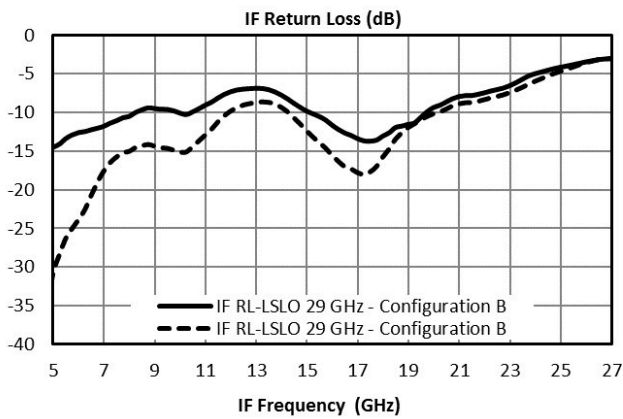
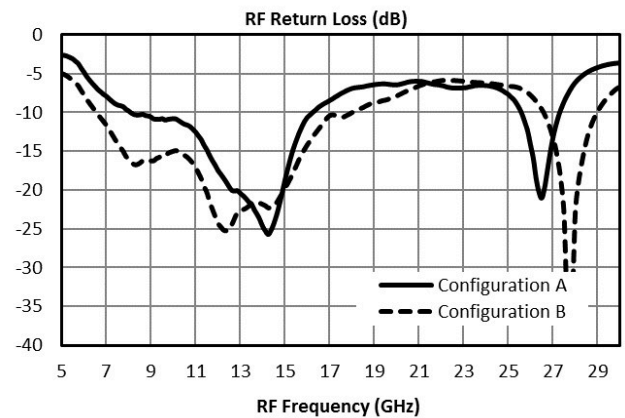
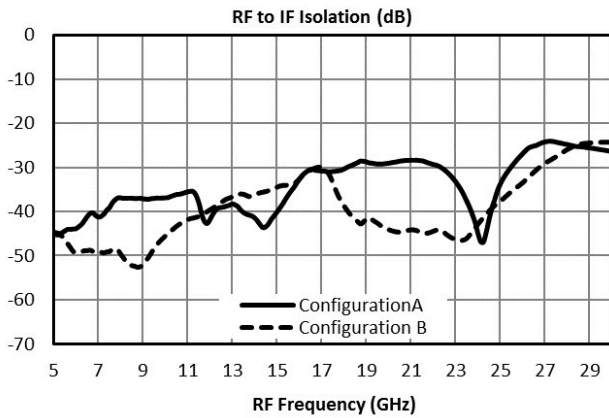
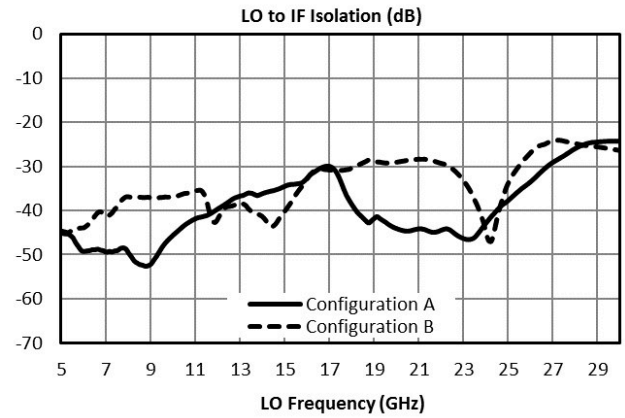
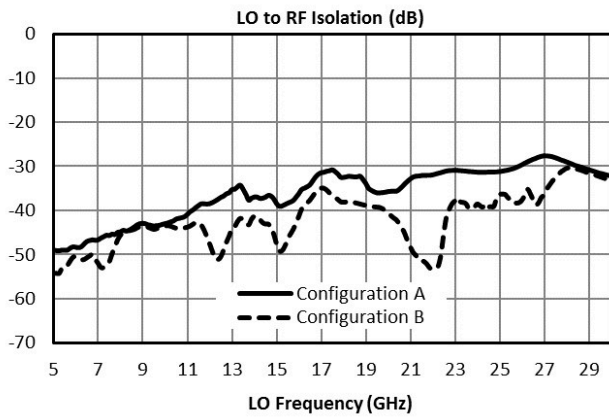

Configuration A Input IP3 vs LO Power: 3 GHz IF, Sine Wave LSLO (dBm)

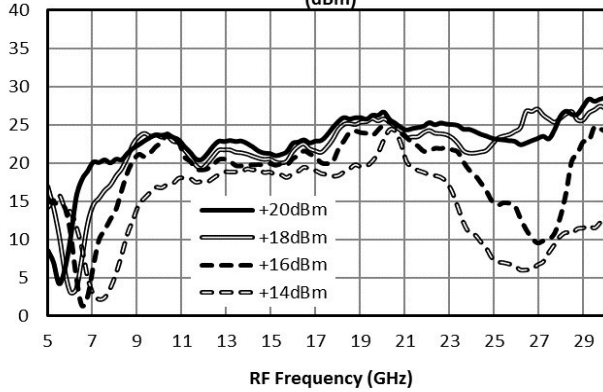

Configuration B Input IP3 vs LO Power: 3 GHz IF, Sine Wave LSLO (dBm)

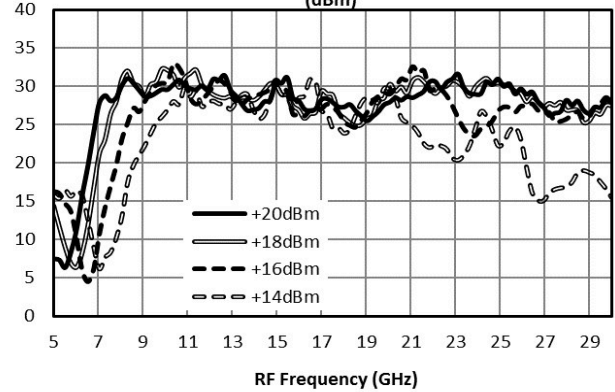

Configuration A Output IP3 vs LO Power: 3 GHz IF, Sine Wave LSLO (dBm)

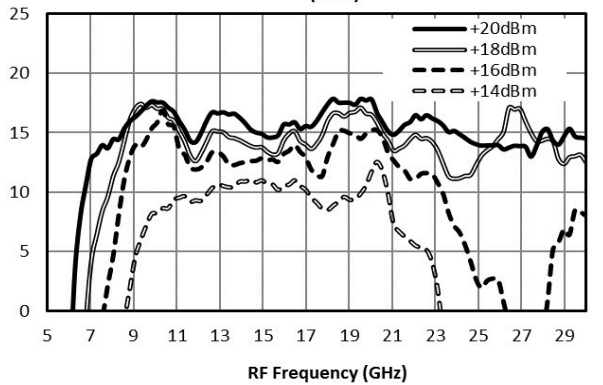

Configuration B Output IP3 vs LO Power: 3 GHz IF, Sine Wave LSLO (dBm)

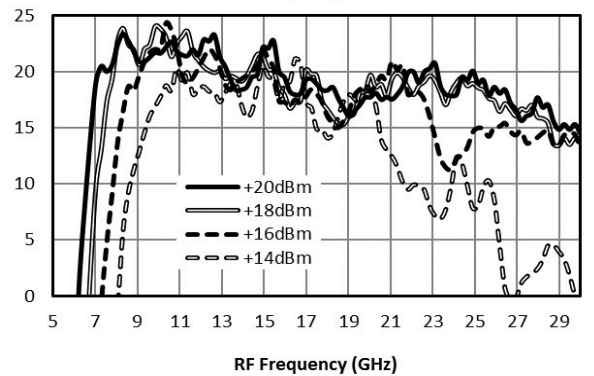

Even LO Harmonic to RF Isolation (dB)

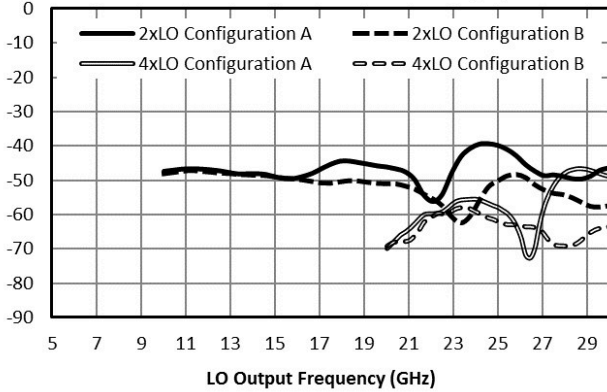

Even LO Harmonic to IF Isolation (dB)

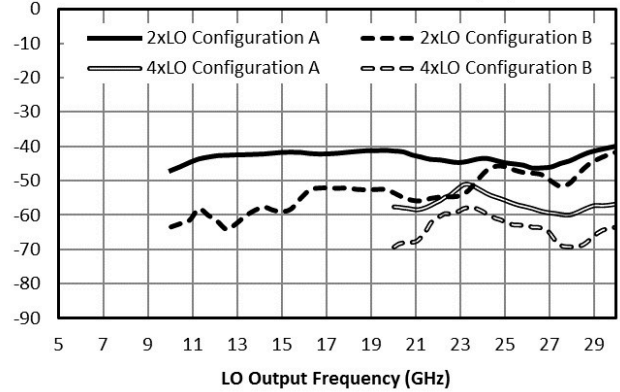

Odd LO Harmonic to RF Isolation (dB)

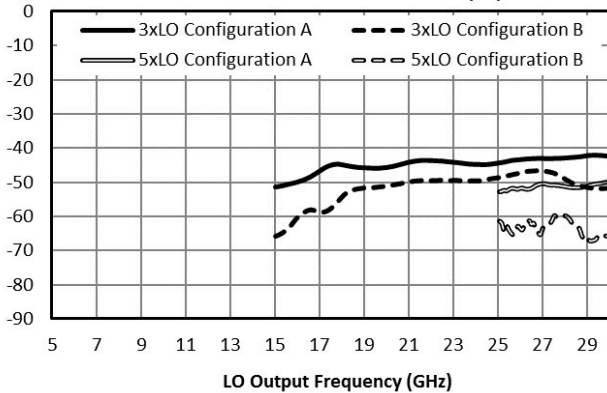

Odd LO Harmonic to IF Isolation (dB)

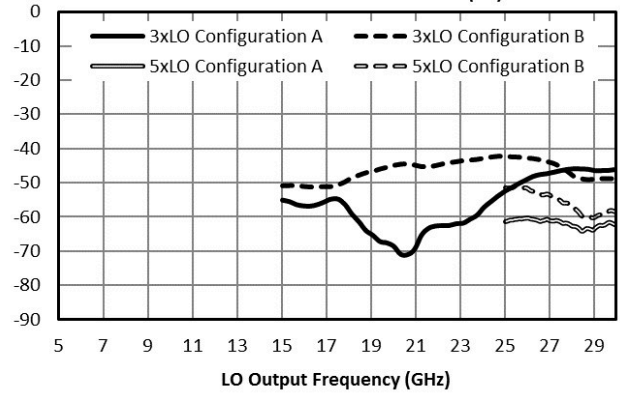

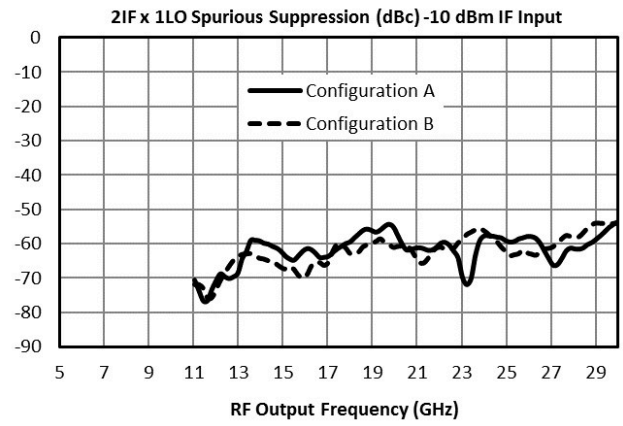
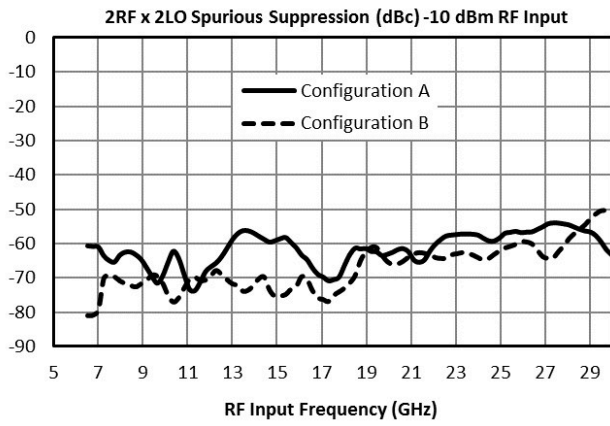

Spur Table

Downconversion Spurious Suppression

Spurious data is taken by selecting RF and LO frequencies (+mLO+nRF) within the 5 to 30 GHz RF/LO bands, which create a 3 GHz IF spurious output. The mixer is swept across the full spurious band and the mean is calculated. The numbers shown in the table below are for a -10 dBm RF input. Spurious suppression is scaled for different RF power levels by (n-1), where “n” is the RF spur order. For example, the 2RFx2LO spur is 62 dBc for the A configuration for a -10 dBm input, so a -20 dBm RF input creates a spur that is (2-1) x (-10 dB) dB lower, or 72 dBc.

Typical Downconversion Spurious Suppression (dBc): A Configuration (B Configuration), Sine Wave LO ⁵

| -10 dBm RF Input | 0xLO | 1xLO | 2xLO | 3xLO | 4xLO | 5xLO |
|-------------------------|-------------|-------------|-------------|-------------|-------------|-------------|
| 1xRF | 27 (30) | Reference | 33 (41) | 18 (13) | 35 (43) | 25 (28) |
| 2xRF | 72 (69) | 62 (61) | 62 (67) | 63 (66) | 66 (72) | 71 (72) |
| 3xRF | 107 (102) | 74 (80) | 95 (95) | 78 (84) | 96 (102) | 79 (87) |
| 4xRF | 155 (152) | 88 (123) | 123 (124) | 119 (126) | 117 (127) | 120 (127) |
| 5xRF | 174 (172) | 138 (142) | 148 (152) | 136 (146) | 146 (152) | 143 (149) |

Specifications are subject to change without notice. Contact Marki Microwave for the most recent specifications and data sheets.

Upconversion Spurious Suppression

Spurious data is taken by mixing a 3 GHz IF with LO frequencies (+mLO+nIF), which creates an RF within the 5 to 30 GHz RF band. The mixer is swept across the full spurious output band and the mean is calculated. The numbers shown in the table below are for a -10 dBm IF input. Spurious suppression is scaled for different IF input power levels by (n-1), where “n” is the IF spur order. For example, the 2IFx1LO spur is typically 62 dBc for the A configuration for a -10 dBm input, so a -20 dBm IF input creates a spur that is (2-1) x (-10 dB) dB lower, or 72 dBc.

Typical Upconversion Spurious Suppression (dBc): A Configuration (B Configuration), Sine Wave LO ⁵

| -10 dBm IF Input | 0xLO | 1xLO | 2xLO | 3xLO | 4xLO | 5xLO |
|-------------------------|-------------|-------------|-------------|-------------|-------------|-------------|
| 1xIF | 30 (34) | Reference | 34 (34) | 13 (12) | 35 (35) | 23 (20) |
| 2xIF | 77 (73) | 62 (62) | 63 (62) | 63 (67) | 72 (69) | 59 (65) |
| 3xIF | 109 (110) | 89 (90) | 100 (103) | 82 (87) | 96 (107) | 82 (85) |
| 4xIF | 126 (122) | 113 (119) | 115 (119) | 120 (125) | 124 (125) | 113 (125) |
| 5xIF | 145 (154) | 130 (140) | 141 (152) | 132 (148) | 141 (145) | 124 (139) |

Specifications are subject to change without notice. Contact Marki Microwave for the most recent specifications and data sheets.

Application Circuit

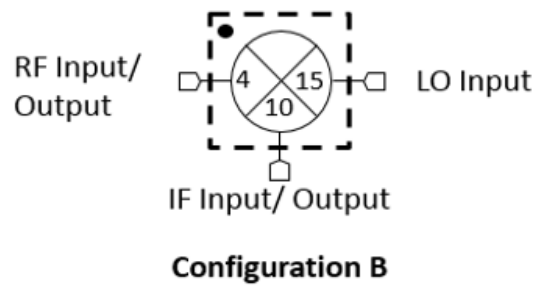
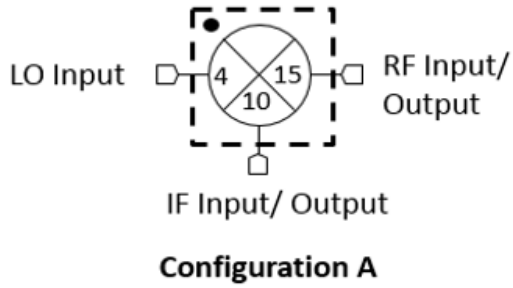

Application Circuit Description

Configuration A/B refer to the same part number (MM2-0530HSM) used in one of two different ways for optimal spurious performance. For the lowest conversion loss, use the mixer in Configuration A (pin 4 as the LO input, pin 15 as the RF input or output). If you need to use a lower LO drive, use the mixer in Configuration B (pin 4 as the RF input or output, pin 15 as the LO input). For optimal spurious suppression, experimentation or simulation is required to choose between Configuration A and B.

Footprint Image

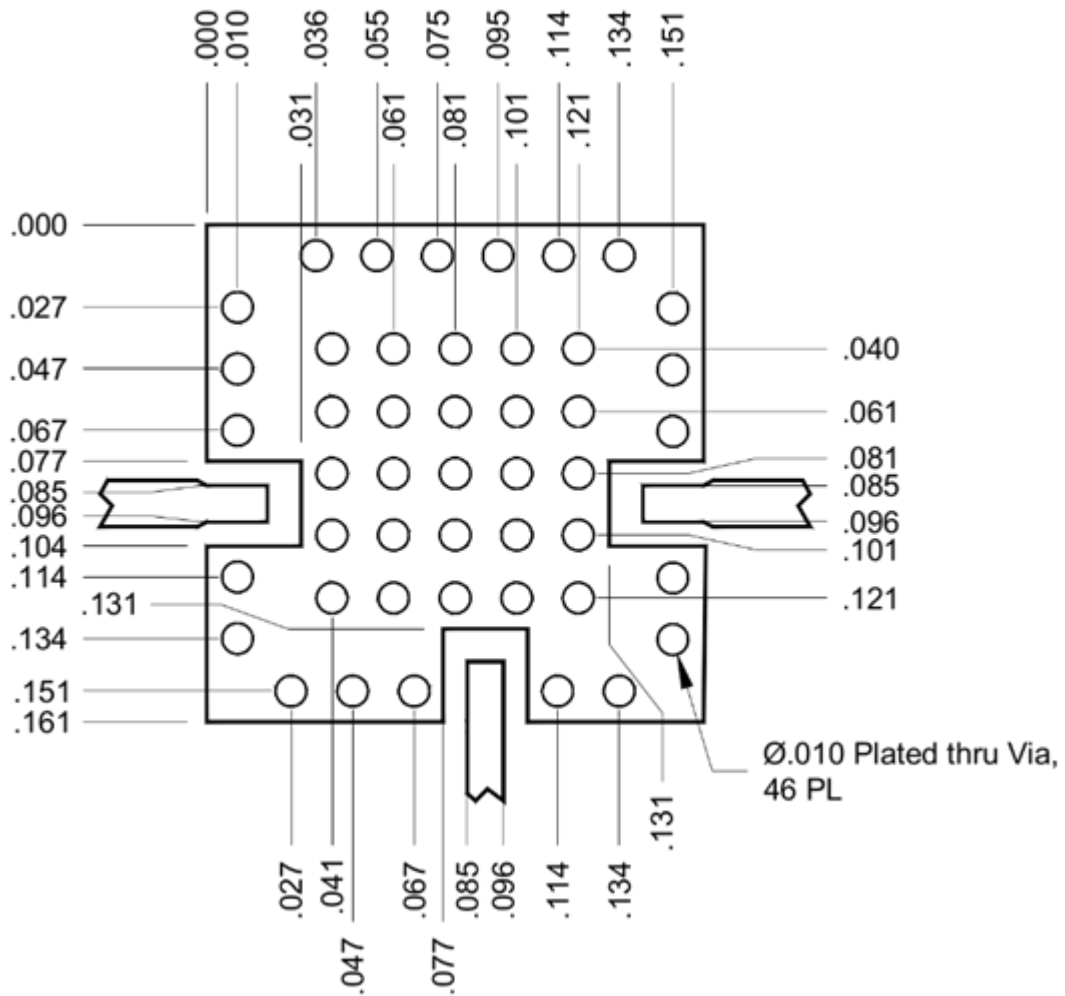

DISCLAIMER

MARKI MICROWAVE, LLC., ("MARKI") PROVIDES TECHNICAL SPECIFICATIONS AND DATA (INCLUDING DATASHEETS), APPLICATION OR OTHER DESIGN ADVICE, WEB TOOLS, AND OTHER INFORMATION AND RESOURCES "AS IS" AND WITH ALL FAULTS. MARKI DISCLAIMS ALL WARRANTIES, EXPRESS OR IMPLIED, INCLUDING, WITHOUT LIMITATION, ANY IMPLIED WARRANTIES OF MERCHANTABILITY, FITNESS FOR A PARTICULAR PURPOSE, OR NON-INFRINGEMENT.

These resources are intended for developers skilled in the art designing with Marki products. You are solely responsible for (1) selecting the appropriate products for your application, (2) designing, validating, and testing your application, and (3) ensuring your application meets applicable standards and other requirements. Marki makes no guarantee regarding the suitability of its products for any particular purpose, nor does Marki assume any liability whatsoever arising out of your use or application of any Marki product.

Marki grants you permission to use these resources only for development of an application that uses Marki products. Other reproduction or use of these resources is strictly prohibited. No license is granted to any other Marki intellectual property or to any third-party intellectual property. Marki reserves the right to make changes to the product(s) or information contained herein without notice.

MARKI MICROWAVE and T3 MIXER are trademarks or registered trademarks of Marki Microwave, LLC. All other trademarks used are the property of their respective owners.

© 2022 - 2026, Marki Microwave, LLC