

# ADM3-0022PA-H Broadband Power Amplifier

## DEVICE OVERVIEW

### General Description

The ADM3-0022PA has the gain and output power to produce 1W of output power from a +0 dBm input power up to 22 GHz. It contains 3 broadband amplifier stages in series in a single package with built-in equalization to provide a flat gain and output power curve. This product is an unprotected amplifier module intended for lab use. See notes section for handling and operating precautions.

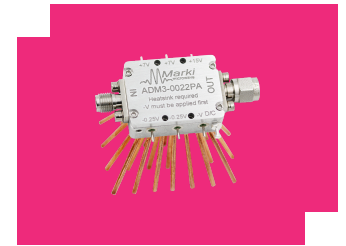

### Features

- +35 dB Small Signal Gain
- Broadband Performance
- +30 dBm Output Power

### Applications

- LO Driver for Marki T3 and MT3 Mixers
- Radar

### Functional Block Diagram

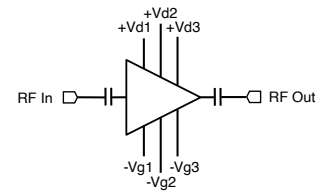

### Part Ordering Options

Part Number	Description	Package	Connectors	Green Status	Product Lifecycle	Export Classification
<a href="#">ADM3-0022PA</a>	Broadband Power Amplifier	PA	<a href="#">Standard</a>	REACH RoHS	Released	EAR99
ADM3-0022PA-H	Broadband Power Amplifier	PA-H	<a href="#">Standard</a>	REACH RoHS	Released	EAR99

**Table Of Contents**

- **Device Overview**
  - General Description
  - Features
  - Applications
  - Functional Block Diagram
- **Port Configuration and Functions**
  - Port Diagram
  - Port Functions
- **Revision History**
- **Specifications**
  - Absolute Maximum Ratings
  - Package Information
  - Recommended Operating Conditions
  - Sequencing Requirements
  - Electrical Specifications
  - Typical Performance Plots
- **Mechanical Data**
  - Outline Drawing
- **Notes**

**Revision History**

Revision Code	Revision Date	Comment
-	2019-08-01	Datasheet Initial Release
A	2020-01-01	Format Update

**Port Configuration and Functions**

**Port Diagram**

A top-down view of the ADM3-0022PA package outline drawing is shown below.

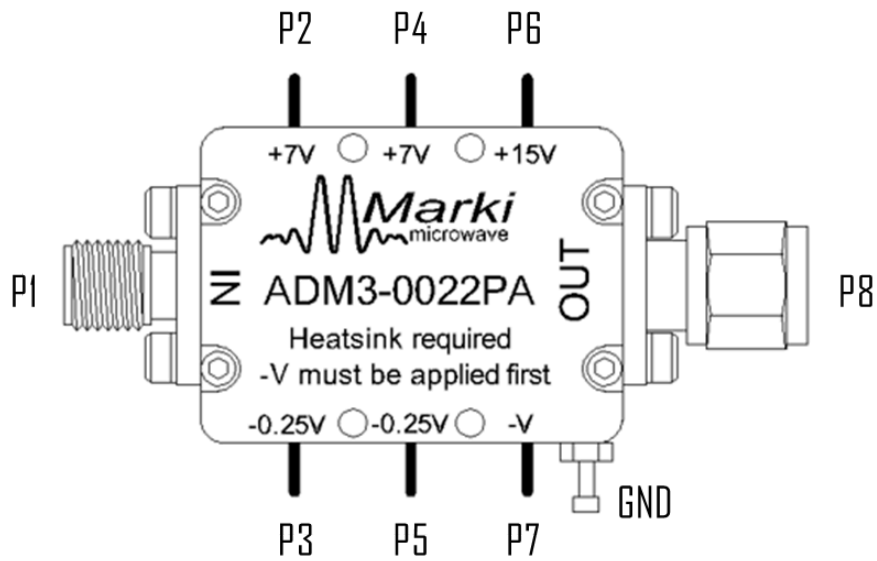

**Port Functions**

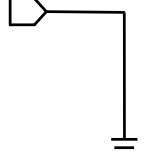
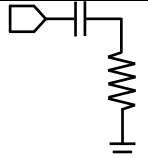
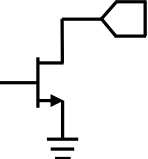
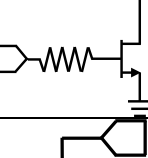
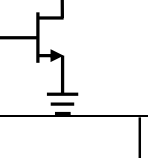
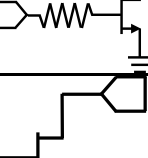
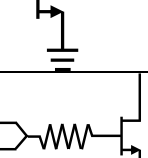
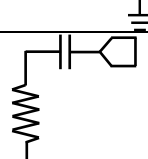
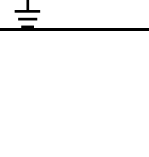
Port	Function	Connector Type	Description	Equivalent Circuit for Package
GND	Gnd	-	Must be connected to a DC/RF ground potential with high thermal and electrical conductivity. Ensure that the ground voltage is a common reference potential to all DC power supplies	
Port 1	RF Input	SMAF	Port 1 is the RF input of the amplifier. It is DC blocked and has a 50 Ω input impedance.	
Port 2	Vd1	-	Port 2 is the positive DC voltage supply pin for the 1st amplifier stage. Nominally 3V – 7V, 155 mA	
Port 3	Vg1	-	Port 3 is the negative DC voltage bias pin for the 1st amplifier stage. Nominally -0.25V, <1 mA	
Port 4	Vd2	-	Port 4 is the positive DC voltage supply pin for the 2nd amplifier stage. Nominally 3V – 7V, 155 mA	
Port 5	Vg2	-	Port 5 is the negative DC voltage bias pin for the 2nd amplifier stage. Nominally -0.25V, <1 mA	
Port 6	Vd3	-	Port 6 is the positive DC voltage supply pin for the 3rd amplifier stage. Nominally 13V-15V, 450 mA. Vg3 must be applied to Port 7 prior to application of Vd3!	
Port 7	Vg3	-	Port 7 is the negative DC voltage bias pin for the 3rd amplifier stage. Nominally -0.85V, <1 mA. Must be applied prior to application of Vd3 on Port 6!	
Port 8	RF Output	SMAM	Port 8 is the RF output of the amplifier. It is DC blocked and has a 50 Ω output impedance. Load must be applied to meet maximum VSWR spec.	

## Specifications

### Absolute Maximum Ratings

The Absolute Maximum Ratings indicate limits beyond which damage may occur to the device. If these limits are exceeded, the device may be inoperable or have a reduced lifetime.

Parameter	Maximum Rating	Unit
Maximum Ambient Air Temperature (with PA-H Package)	40	°C
Maximum Case Temperature	60	°C
Maximum Storage Temperature	125	°C
Minimum Ambient Air Temperature (with PA-H Package)	-40	°C
Minimum Case Temperature	-40	°C
Minimum Storage Temperature	-65	°C
Negative Bias Voltage 1 (Port 3)	-2	V
Negative Bias Voltage 2 (Port 5)	-2	V
Negative Bias Voltage 3 (Port 7)	-3	V
Output Load VSWR	7	-
Positive Bias Current 1 (Port 2)	275	mA
Positive Bias Current 2 (Port 4)	275	mA
Positive Bias Current 3 (Port 6)	500	mA
Positive Bias Voltage 1 (Port 2)	9	V
Positive Bias Voltage 2 (Port 4)	9	V
Positive Bias Voltage 3 (Port 6)	15	V
RF Input Power (Port 1)	5	dBm

### Package Information

Parameter	Details	Rating
ESD	250 to < 500 Volts	HBM Class 1A
Weight	Package name: PA-H	44.5g
Dimensions	-	29.46 x 22.10 mm

### Recommended Operating Conditions

The Recommended Operating Conditions indicate the limits, inside which the device should be operated, to guarantee the performance given in Electrical Specifications. Operating outside these limits may not necessarily cause damage to the device, but the performance may degrade outside the limits of the electrical specifications. For limits, above which damage may occur, see Absolute Maximum Ratings. To keep the temperature below 60°C, the user is advised to use a fan to keep a constant airflow over the heat sink.

Parameter	Min	Nominal	Max	Unit
Positive DC Voltage (Port 6)	12	15	15	V
Positive DC Current (Port 2, Port 4)	100	155	275	mA
Positive DC Voltage (Port 2, Port 4)	3	7	7	V
Positive DC Current (Port 6) <sup>1</sup>	200	450	500	mA
Ambient Temperature	-40	25	40	°C

<sup>[1]</sup> To protect the output stage of the module, ensure that Port 6 never pulls more than 500 mA of DC current. Current pull will increase with increased RF input power and with decreased negative bias on Port 7.

### Sequencing Requirements

The output stage of this module uses an amplifier IC which requires a sequenced turn-on and turn-off procedure.

Turn-on:

1. Ensure port 8 (RF output) is connected to load
2. Apply -1V to port 7 (Vg3)
3. Ramp port 6 (Vd3) to operating voltage
4. a. Apply -0.25 V to port 5 (Vg2)
- b. Apply -0.25 V to port 3 (Vg1)
5. a. Apply + V to port 4 (Vd2)

**Electrical Specifications**

The electrical specifications apply at TA=+25°C in a 50Ω system. Min and Max limits apply only to our connectorized units and are guaranteed at TA=+25°C.

Parameter	Test Conditions	Minimum Frequency (GHz)	Maximum Frequency (GHz)	Min	Typ	Max	Unit
Bias Requirements	15V/-0.85 (Ports 6/7), no RF	-	-	-	185	-	mA
Bias Requirements	7V/-0.25V (Ports 2/3), no RF	-	-	-	155	-	mA
Bias Requirements	7V/-0.25V (Ports 4/5), no RF	-	-	-	155	-	mA
Input IP3	7V/-0.25V, 7V/-0.25V, 15V/-0.85V, -25 dBm Input Power	-	-	-	-4	-	dBm
Input Return Loss	7V/-0.25V, 7V/-0.25V, 15V/-0.85V, -25 dBm Input Power	-	-	-	14	-	dB
Noise Figure	7V/-0.25V, 7V/-0.25V, 15V/-0.85V, -25 dBm Input Power	-	-	-	5	-	dB
Output IP3	7V/-0.25V, 7V/-0.25V, 15V/-0.85V, -25 dBm Input Power	-	-	-	31	-	dBm
Output P1dB	7V/-0.25V, 7V/-0.25V, 15V/-0.85V	-	-	-	26	-	dBm
Output Power	7V/-0.25V, 7V/-0.25V, 15V/-0.85V, -5 dBm Input Power	-	-	25	30	-	dBm
Output Return Loss	7V/-0.25V, 7V/-0.25V, 15V/-0.85V, -25 dBm Input Power	-	-	-	14	-	dB
Reverse Isolation	7V/-0.25V, 7V/-0.25V, 15V/-0.85V, -25 dBm Input Power	-	-	-	70	-	dB
Small Signal Gain	7V/-0.25V, 7V/-0.25V, 15V/-0.85V, -25 dBm Input Power	-	-	28	35	-	dB

**Typical Performance Plots**

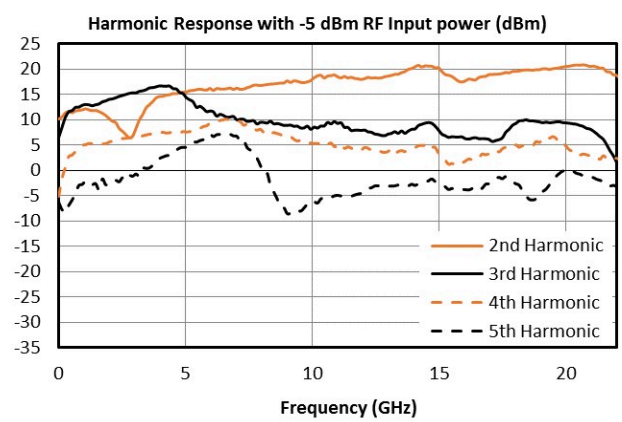
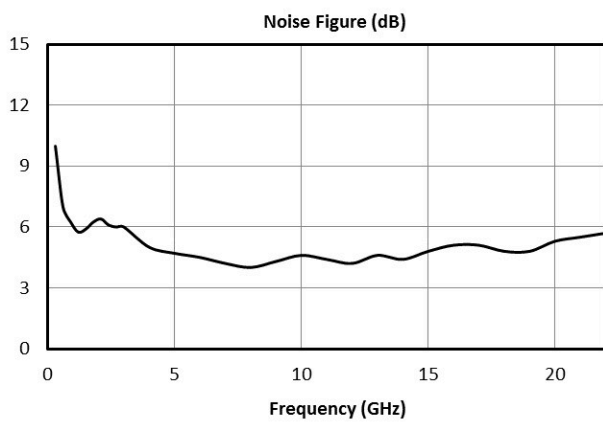
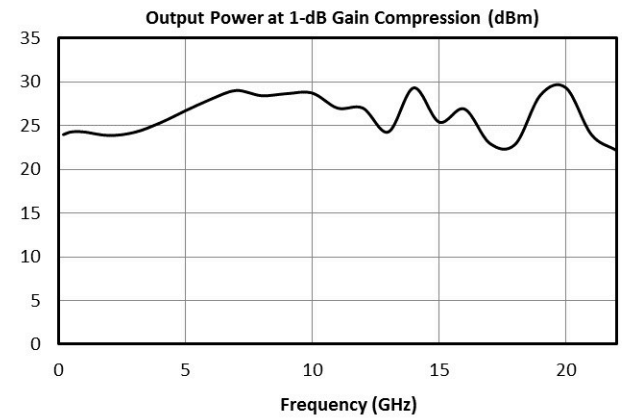
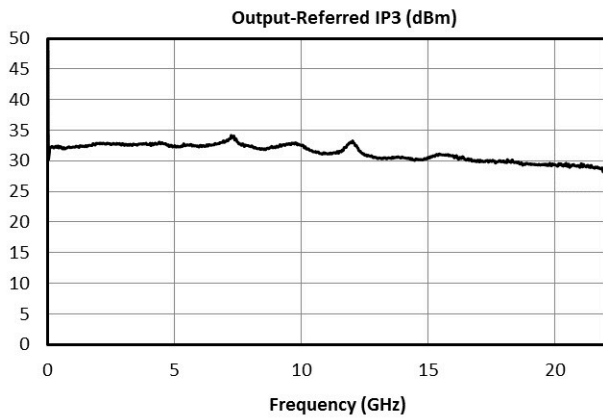
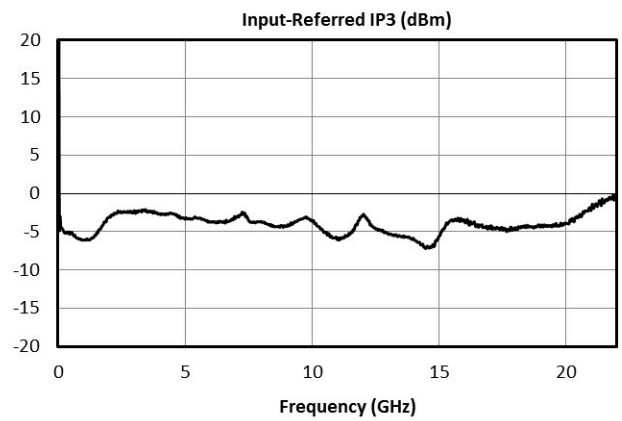
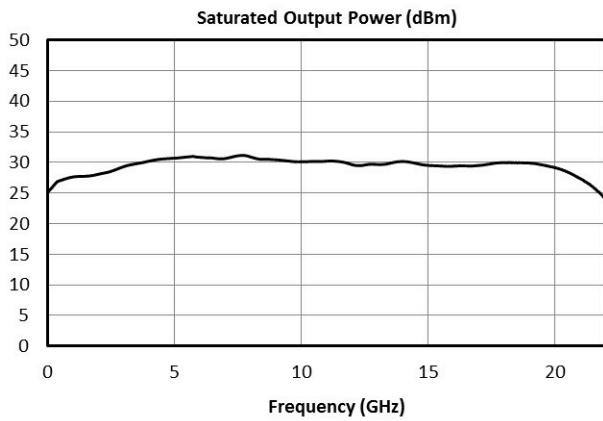
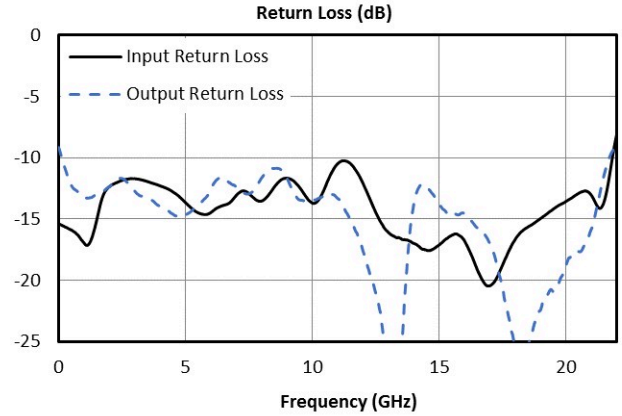
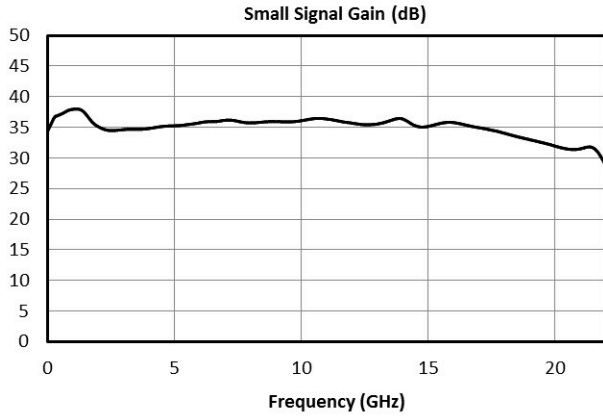

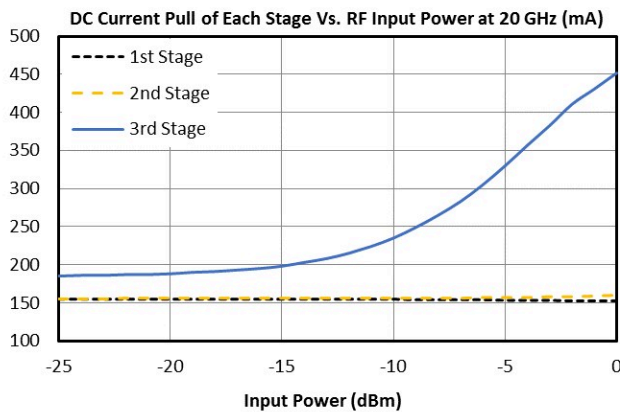
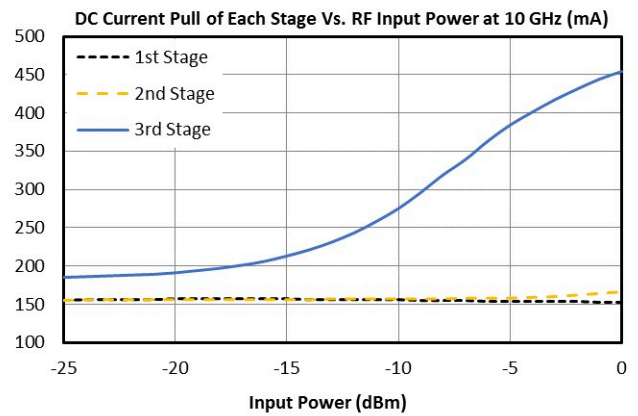
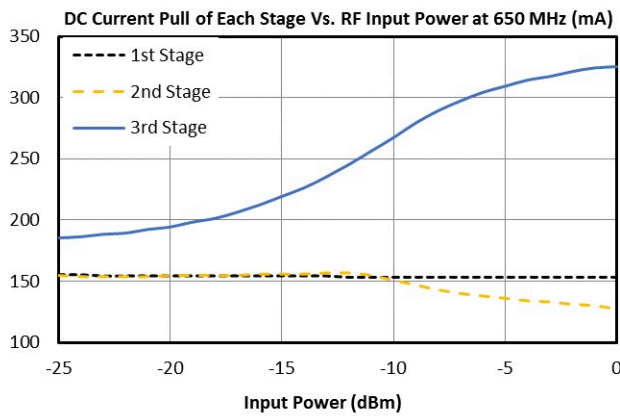
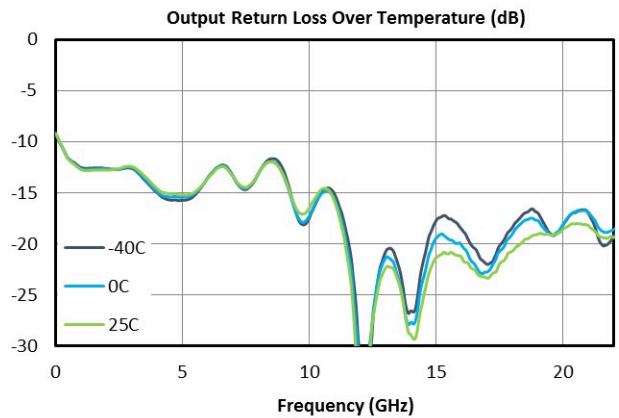
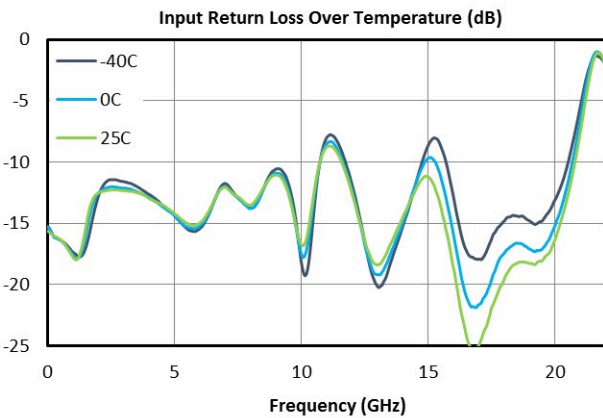
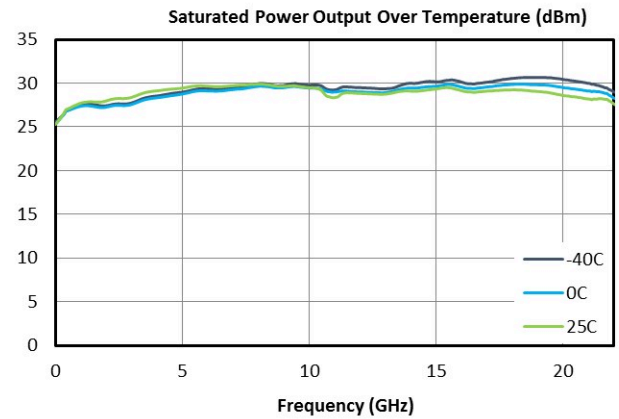
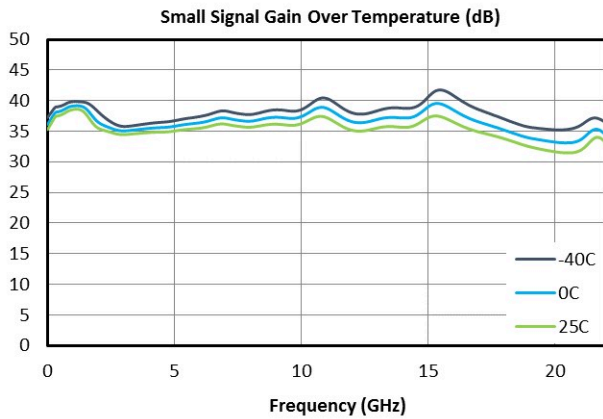

**Mechanical Data**

**Outline Drawing**

Download : [Outline 3D Drawing](#) | [Outline 3D STP](#)

Port	Connector Type
In	SMA Female
Out	SMA Male

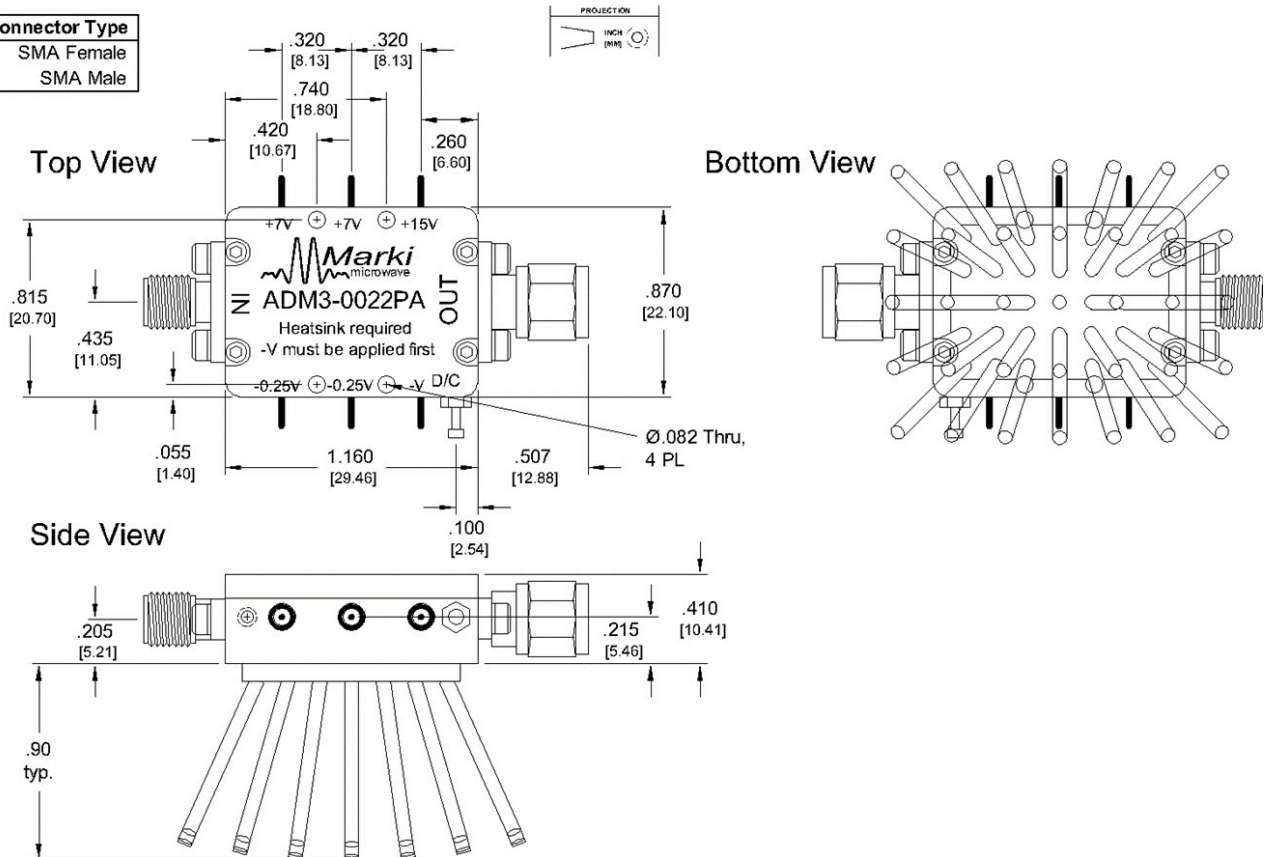

## Notes

The ADM3-0022PA is for use in a controlled laboratory environment and is **not** suitable for use in high reliability applications.

Module may be catastrophically damaged by heat. Special care must be taken to maintain operating temperature within limits.

Forced air cooling (such as a fan) must be continuously applied with abundant heat sinking to maintain proper operating temperature of the ADM3-0022PA-H.

Third stage amplifier may be catastrophically damaged by incorrect sequencing or disruption of the negative supply voltage. Always sequence according to sequencing requirements.

Operation of the amplifier without a load or with excessive output reflections can catastrophically damage the module. Always adhere to the maximum load VSWR in Absolute Maximum Ratings.

Care must be taken to reduce or eliminate ESD discharge in the test environment.

Users must rigidly adhere to absolute maximums and sequencing procedure to prevent catastrophic failure.

Care must be taken to prevent damage due to excessive DC current, overheating, ESD, and damage due to large output reflections.

## DISCLAIMER

MARKI MICROWAVE, INC., ("MARKI") PROVIDES TECHNICAL SPECIFICATIONS AND DATA (INCLUDING DATASHEETS), APPLICATION OR OTHER DESIGN ADVICE, WEB TOOLS, AND OTHER INFORMATION AND RESOURCES "AS IS" AND WITH ALL FAULTS. MARKI DISCLAIMS ALL WARRANTIES, EXPRESS OR IMPLIED, INCLUDING, WITHOUT LIMITATION, ANY IMPLIED WARRANTIES OF MERCHANTABILITY, FITNESS FOR A PARTICULAR PURPOSE, OR NON-INFRINGEMENT.

These resources are intended for developers skilled in the art designing with Marki products. You are solely responsible for (1) selecting the appropriate products for your application, (2) designing, validating, and testing your application, and (3) ensuring your application meets applicable standards and other requirements. Marki makes no guarantee regarding the suitability of its products for any particular purpose, nor does Marki assume any liability whatsoever arising out of your use or application of any Marki product.

Marki grants you permission to use these resources only for development of an application that uses Marki products. Other reproduction or use of these resources is strictly prohibited. No license is granted to any other Marki intellectual property or to any third-party intellectual property. Marki reserves the right to make changes to the product(s) or information contained herein without notice.

MARKI MICROWAVE and T3 MIXER are trademarks or registered trademarks of Marki Microwave, Inc. All other trademarks used are the property of their respective owners.

© 2019 - 2020, Marki Microwave, Inc