

ADM-8350PSM

0.09 - 6 GHz High Dynamic Range Gain Block

DEVICE OVERVIEW

General Description

The ADM-8350PSM is a high-linearity, low noise amplifier capable of providing +22 dBm output power up to 6 GHz. The ADM-8350PSM can serve either as a linear signal amplifier, or as a saturated driver amplifier for H- or S-diode mixers. The amplifier has excellent return losses, gain flatness, and high IP3. The ADM-8350PSM is similar to the ADM-8095. The main difference is that the IP3 is higher for the ADM-8350.

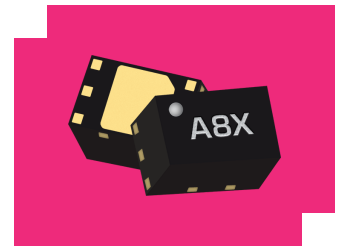

[Download s-parameters here](#)

Features

- +22 dBm output power
- +23 dB gain
- +39.5dBm OIP3
- No negative bias required

Applications

- Mobile test and measurement equipment
- Radar and satellite communications
- Driver Amplifier for H and S - Diode Mixers

Functional Block Diagram

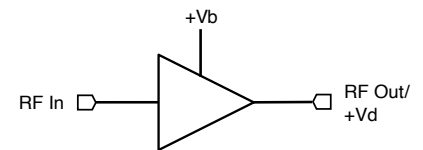

Part Ordering Options

Part Number	Description	Package	Green Status	Product Lifecycle	Export Classification
ADM-8350PSM	0.09 - 6 GHz High Dynamic Range Gain Block	DFN	REACH RoHS	Released	EAR99
EVB-ADM-8350P	Evaluation Board, 0.09 - 6 GHz High Dynamic Range Gain Block	EVB	REACH RoHS	Released	EAR99

Table Of Contents

- **Device Overview**
 - General Description
 - Features
 - Applications
 - Functional Block Diagram
- **Port Configuration and Functions**
 - Port Diagram
 - Port Functions
- **Revision History**
- **Specifications**
 - Absolute Maximum Ratings
 - Package Information
 - Recommended Operating Conditions
 - Sequencing Requirements
 - Electrical Specifications
 - ADM-8350PSM Typical Performance Plots
- **Operation**
 - Application Information
 - Application Circuit
- **Mechanical Data**
 - Outline Drawing
- **Footprint Image**
- **Evaluation Board**
 - Evaluation Board Outline Drawing

Revision History

Revision Code	Revision Date	Comment
-	2023-02-01	Initial Release

Port Configuration and Functions

Port Diagram

A port diagram of the ADM-8350PSM QFN package is shown below (X-ray view from the top). The pin functions are detailed below.

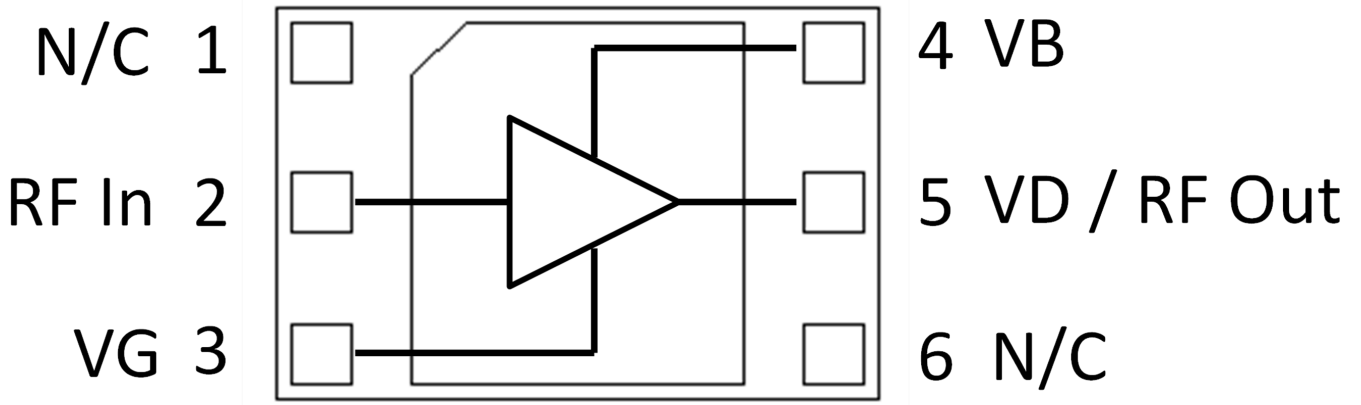

Port Functions

Port	Function	Description	Equivalent Circuit for Package
1,6	N/C	Pin 1 and Pin 6 are internally no-connects and should be connected to DC/RF ground.	-
2	RF Input	Pin 2 is the RF Input port of the amplifier. It is internally RF matched to 50 Ω and requires an external DC blocking cap.	-
3	Vg	Pin 3 is an external bias resistor connection. The gate is internally biased by the Vd supply, therefore a supply voltage should not be applied to Vg. The default resistor is 1k Ω shunt to GND.	-
4	Vb	Pin 4 is the current mirror DC voltage supply port that controls the drain current. The VB supply should be tied to the VD supply through an external supply. Increasing the current will increase OIP3 at the expense of efficiency. The default series resistor is 1.5k Ω to optimize gain, output power, and efficiency when VB and VD are both tied to 5V.	-
5	Vd / RF Out	Pin 5 is the RF Output port and is also the Vd port providing the main power supply to the amplifier. This pin is DC coupled and requires an external bias-T or discrete choke and DC blocking capacitor. This port is RF matched to 50 Ω . DC voltage at this pin should be set to 5V for normal operation.	-
Paddle	Gnd	Package ground paddle must be connected to a DC/RF ground potential with high thermal and electrical conductivity.	-

Specifications

Absolute Maximum Ratings

The Absolute Maximum Ratings indicate limits beyond which damage may occur to the device. If any one of these limits are exceeded, the device may become inoperable or have a reduced lifetime. Reliability limits are individual, instantaneous catastrophic limits only. Functional operation limits are indicated below. Operation of the device at multiple absolute maximum limits or for extended periods at a single limit can cause degradation and damage to the device.

Parameter	Maximum Rating	Unit
Drain Current (Id) (No RF Applied)	120	mA
Drain Supply Voltage (Vd)	6.5	V
Maximum Operating Temperature for MTTF > 1E6 hours	85	°C
Maximum Storage Temperature	125	°C
Max Junction Temperature for MTTF of >1E6 hours	175	°C
Max Power Dissipation for MTTF of > 1E6 hours	1	W
Minimum Operating Temperature for MTTF > 1E6 hours	-40	°C
Minimum Storage Temperature	-65	°C
RF Input Power	15	dBm
θ_{Jc} , Junction to Case Thermal Resistance	85	°C/W

Package Information

Parameter	Details	Rating
Weight	Package name: DFN	0.007g
Dimensions	-	1.3 x 2 mm
Moisture Sensitivity Level	-	MSL 1

Recommended Operating Conditions

The Recommended Operating Conditions indicate the limits, inside which the device should be operated, to guarantee the performance given in Electrical Specifications. Operating outside these limits may not necessarily cause damage to the device, but the performance may degrade outside the limits of the electrical specifications. For limits, above which damage may occur, see Absolute Maximum Ratings.

Parameter	Min	Nominal	Max	Unit
Input Power for Saturation	2	4	6	dBm
Power Supply DC Voltage (Vd)	3	5	6	V
Ambient Temperature	-40	25	85	°C
Power Supply DC Current (Id) (No RF Input) ¹	46	84	102	mA

^[1] Recommended operating current conditions without RF input applied.

Sequencing Requirements

There is no sequencing required to power up or power down the amplifier. The amplifier must have an output load connected during operation.

Electrical Specifications

Unless otherwise specified, electrical specifications apply at TA=+25°C, Vd = Vb = 5 V.

Parameter	Test Conditions	Minimum Frequency (GHz)	Maximum Frequency (GHz)	Min	Typ	Max	Unit
DC Supply Quiescent Current (Idq)	Vd = 5 V, no RF input	0.09	6	-	84	-	mA
Input IP3	Vd = 5 V, Pin = -15 dBm per tone, 10 MHz tone spacing	0.09	6	-	17	-	dBm
Input Power for Saturation	Vd = 5V	0.09	6	2	4	-	dBm
Input Return Loss	Vd = 5 V, Pin = -20 dBm	0.09	6	-	15	-	dB
Noise Figure	Vd = 5 V, Pin = -20 dBm	0.09	3	-	1.8	-	dB
Noise Figure	Vd = 5 V, Pin = -20 dBm	3	6	-	2.5	-	dB
Output IP2	Vd = 5 V, Pin = -15 dBm per tone, 10 MHz tone spacing	0.09	6	-	37	-	dBm
Output IP3	Vd = 5 V, Pin = -15 dBm per tone, 10 MHz tone spacing	0.09	6	-	40	-	dBm
Output P1dB	Vd = 5V	0.09	6	-	22	-	dBm
Output Power	Vd = 5 V	0.09	6	20	22	-	dBm
Output Return Loss	Vd = 5 V, Pin = -20 dBm	0.09	6	-	14	-	dB
Reverse Isolation	Vd = 5 V, Pin = -20 dBm	0.09	6	-	28	-	dB
Small Signal Gain	Vd = 5 V, Pin = -20 dBm	0.09	6	21	23	-	dB

ADM-8350PSM Typical Performance Plots

⁴ Data is scalar de-embedded with thru-line fixture.

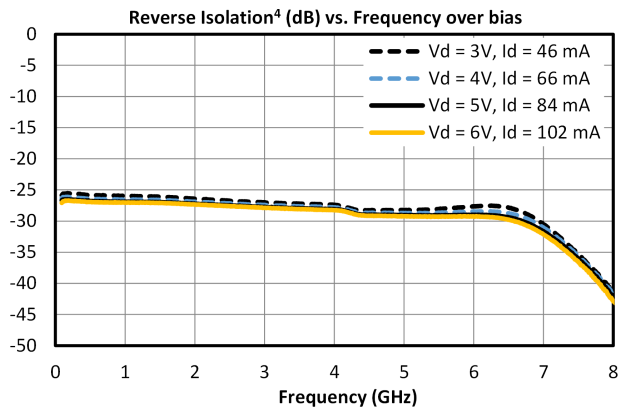
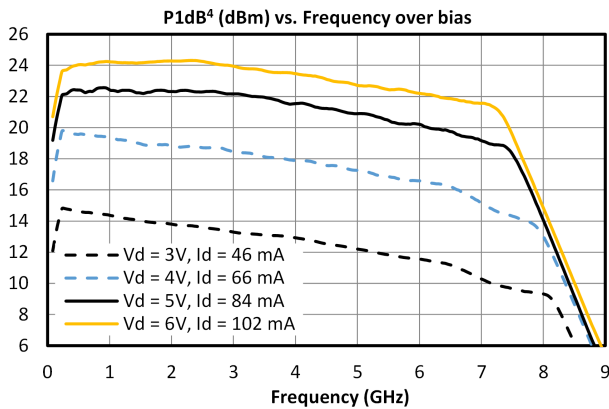
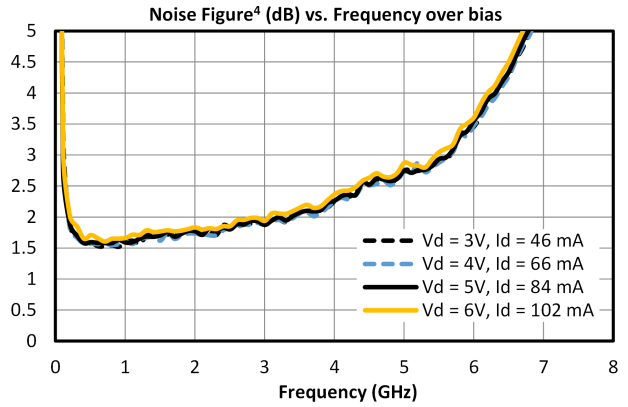
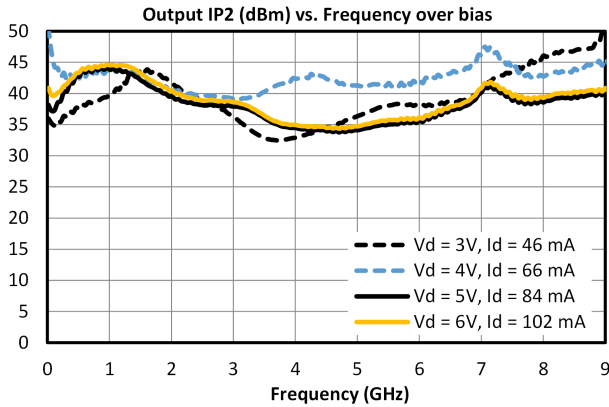
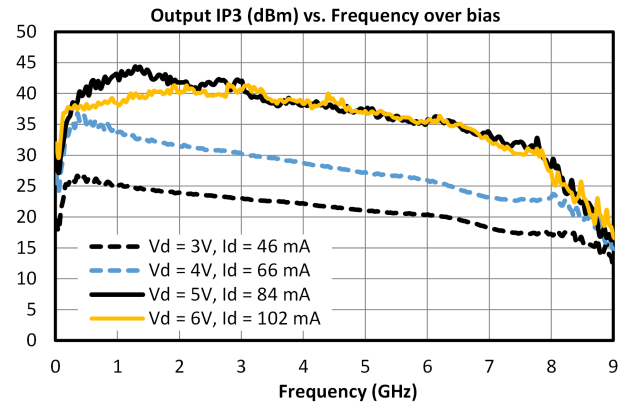
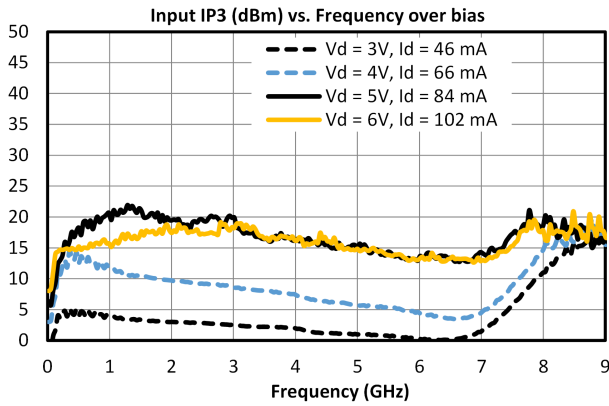
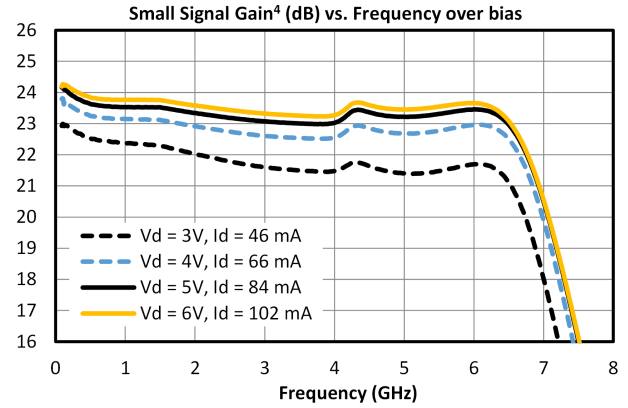
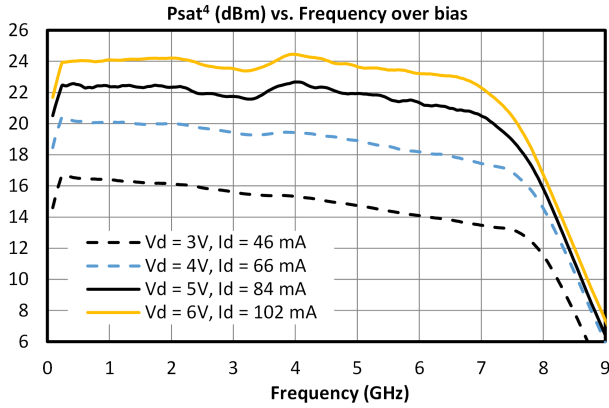

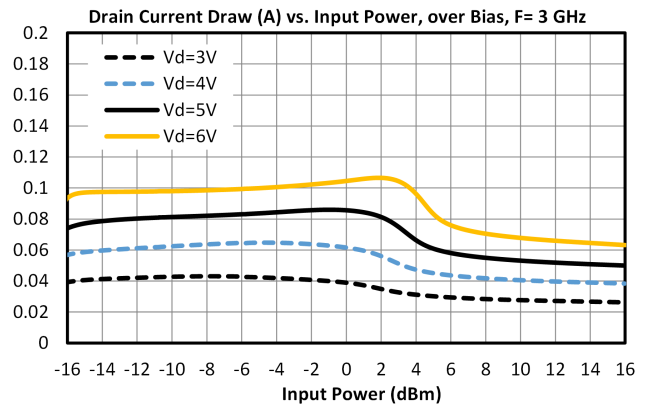
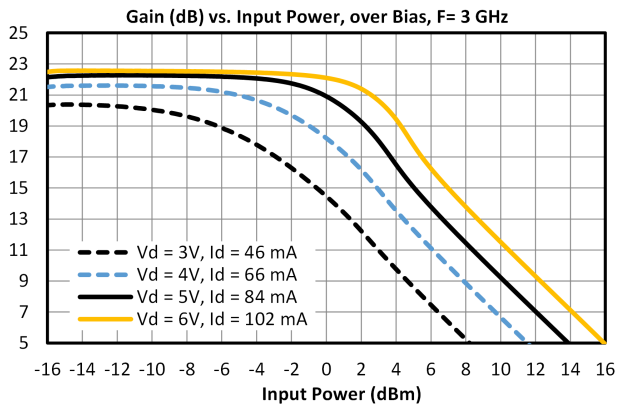
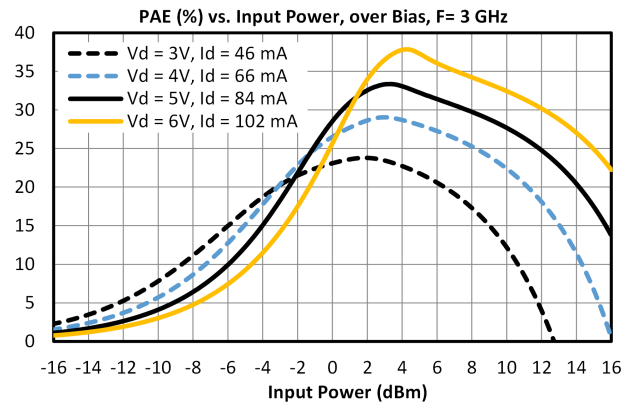
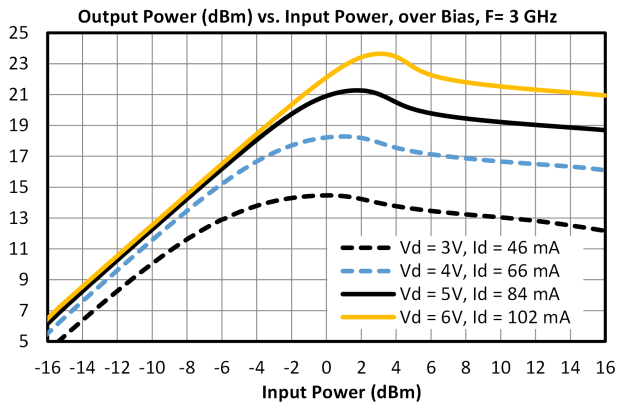
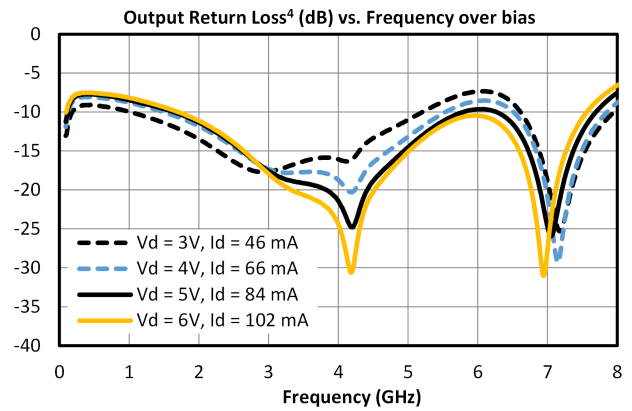
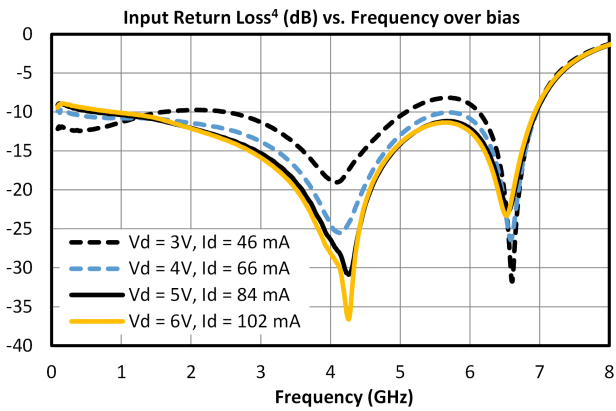

Application Information

Application Circuit

Below is the recommended application circuit for the ADM-8350PSM. DC power is supplied to RF Out/Vd pin 5 via a 150 nH choke inductor. Vb is also supplied through a 1.5k Ω resistor tied to the Vd power supply. Supply bypassing is provided by 100pf and 0.1uF capacitors. Drain current Id is controlled by applying voltage to Vb pin4. Drain current Id is adjusted proportionally to the current flowing into pin 4 where the default 1.5k Ω is set to maximize linearity. Amplifier performance is optimized for improved IP3 performance using the external gate resistor on the Vg line. A supply voltage should not be applied to Vg. The ADM-8350PSM requires an RF input matching network at RF In pin 2 as shown. DC blocking capacitors are also required at RF input and output pins as shown. Note that EVB-ADM-8350P does not include DC blocking capacitors and must be externally blocked. See Section 5.4 for more details on the EVB circuit layout and component values. Contact support@markimicrowave.com if you would like help creating an alternative application circuit for your system's requirements.

Application Circuit

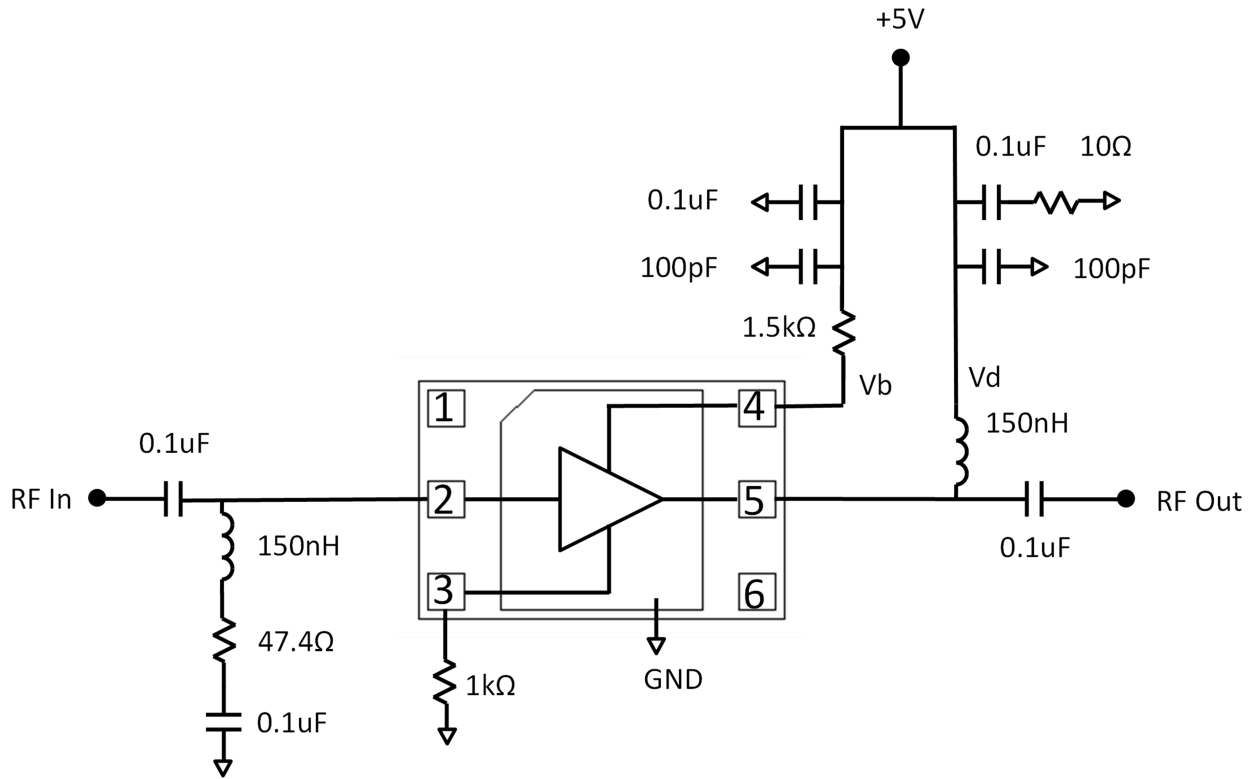

Mechanical Data

Outline Drawing

Download : [Outline 2D Drawing](#) | [Outline 3D Drawing](#) | [Outline 3D STP](#)

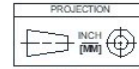

All dimensions are typical

Pad #	Function
1	N/C
2	RF In
3	VG
4	VB
5	RF Out/VD
6	N/C

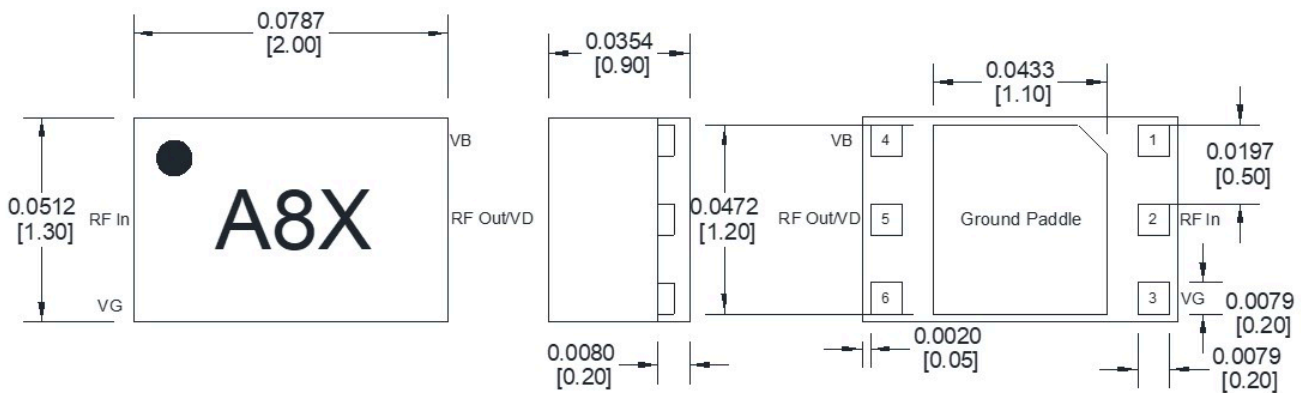

Notes (unless otherwise specified):

1. Substrate material is LCP.
2. I/O Leads and Die Paddle are 0.05 microns Au over 0.02 microns Pd over 0.5 micron Ni.
3. All unconnected pins should be connected to PCB RF ground.

Footprint Image

Download : [Footprint Drawing](#)

DFN X-Ray view

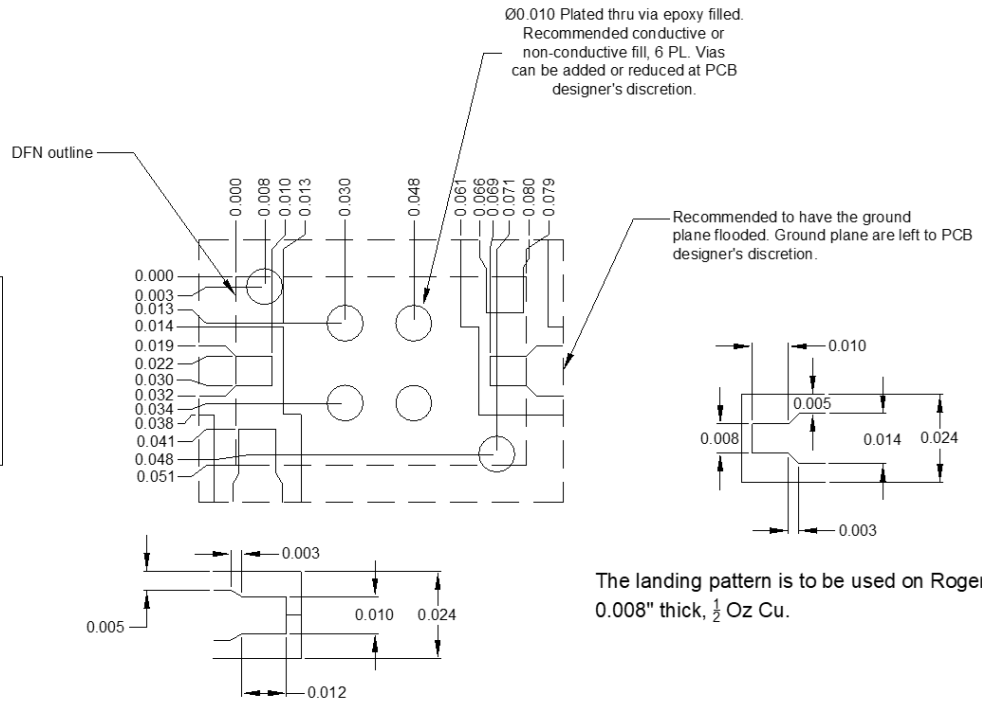
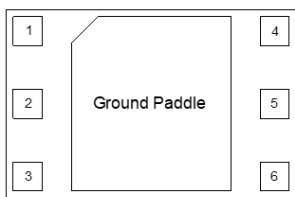

The landing pattern is to be used on Rogers 4003, 0.008" thick, ½ Oz Cu.

Evaluation Board - Outline Drawing

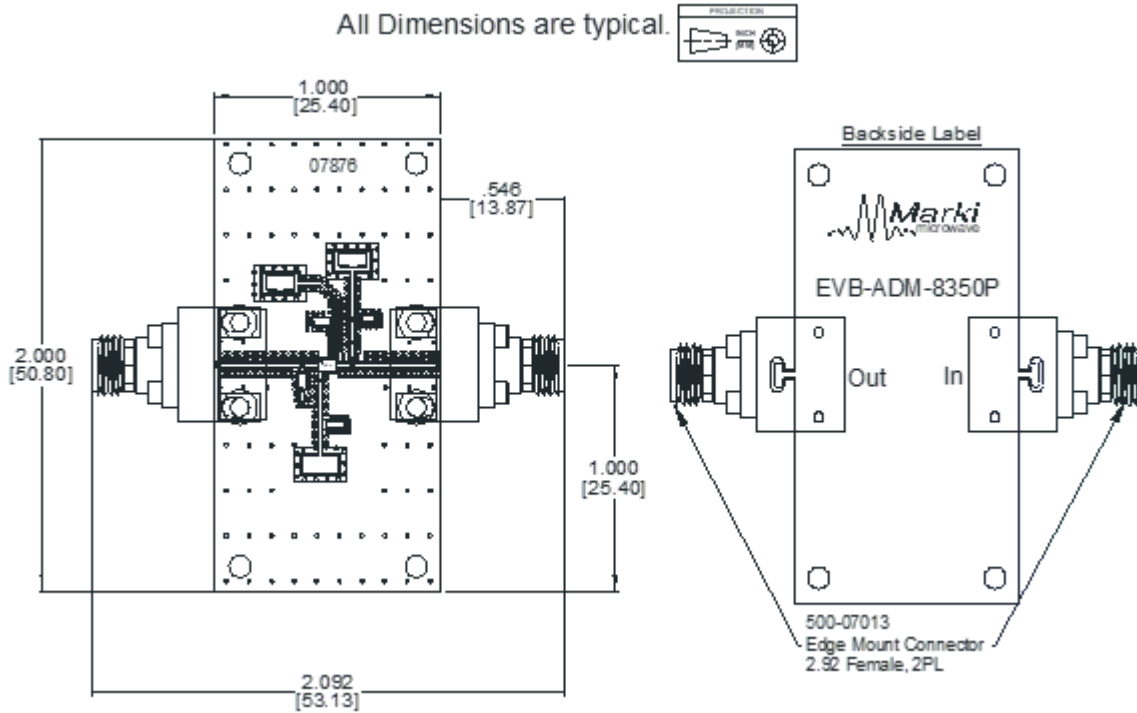

DISCLAIMER

MARKI MICROWAVE, INC., ("MARKI") PROVIDES TECHNICAL SPECIFICATIONS AND DATA (INCLUDING DATASHEETS), APPLICATION OR OTHER DESIGN ADVICE, WEB TOOLS, AND OTHER INFORMATION AND RESOURCES "AS IS" AND WITH ALL FAULTS. MARKI DISCLAIMS ALL WARRANTIES, EXPRESS OR IMPLIED, INCLUDING, WITHOUT LIMITATION, ANY IMPLIED WARRANTIES OF MERCHANTABILITY, FITNESS FOR A PARTICULAR PURPOSE, OR NON-INFRINGEMENT. These resources are intended for developers skilled in the art designing with Marki products. You are solely responsible for (1) selecting the appropriate products for your application, (2) designing, validating, and testing your application, and (3) ensuring your application meets applicable standards and other requirements. Marki makes no guarantee regarding the suitability of its products for any particular purpose, nor does Marki assume any liability whatsoever arising out of your use or application of any Marki product.

Marki grants you permission to use these resources only for development of an application that uses Marki products. Other reproduction or use of these resources is strictly prohibited. No license is granted to any other Marki intellectual property or to any third-party intellectual property. Marki reserves the right to make changes to the product(s) or information contained herein without notice.

MARKI MICROWAVE and T3 MIXER are trademarks or registered trademarks of Marki Microwave, Inc. All other trademarks used are the property of their respective owners.

© 2023, Marki Microwave, Inc