

# MSW2-00001CH

## 2-26 GHz MMIC GaAs PIN SPDT Switch

### DEVICE OVERVIEW

#### General Description

The MSW2-00001CH is a reflective, single-pole double throw (SPDT) switch. The switch operates from 2 GHz to 26 GHz with average insertion loss and isolation of 0.8 dB and 52 dB respectively. The MSW2-00001CH requires positive and negative 5V supply inputs to control switch states. This switch has a 50-Ohm characteristic impedance. The MSW2-00001CH is available as a wire-bondable die.

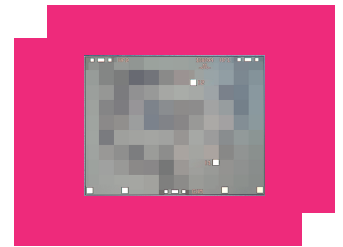

[Download s-parameters here](#)

#### Features

- 0.8 dB Insertion loss
- 52 dB Isolation
- 4 ns switching time
- +41 dBm Input IP3
- Low Power Consumption

#### Applications

- Mobile test and measurement equipment
- Radar
- SATCOM
- Electronic Warfare

#### Functional Block Diagram

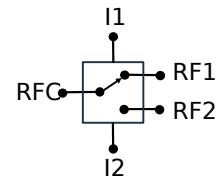

#### Part Ordering Options

Part Number	Description	Package	Green Status	Product Lifecycle	Export Classification
MSW2-00001CH	2-26 GHz MMIC GaAs PIN SPDT Switch	CH	REACH RoHS	Released	EAR99

## Table Of Contents

- **Device Overview**
  - General Description
  - Features
  - Applications
  - Functional Block Diagram
- **Port Configuration and Functions**
  - Port Diagram
  - Port Functions
- **Revision History**
- **Specifications**
  - Absolute Maximum Ratings
  - Package Information
  - Recommended Operating Conditions
  - Electrical Specifications
  - Typical Performance Plots
- **Die Mounting Recommendations**
  - Mounting and Bounding Recommendations
- **Operation**
  - Application Information
  - Application Circuit
- **Mechanical Data**
  - Outline Drawing

## Revision History

Revision Code	Revision Date	Comment
-	2025-05-23	Initial Release
A	2025-06-02	Updated IP3 and P1dB plots frequency range.

## Port Configuration and Functions

### Port Diagram

A top-down view of the MSW2-00001CH die is show below.

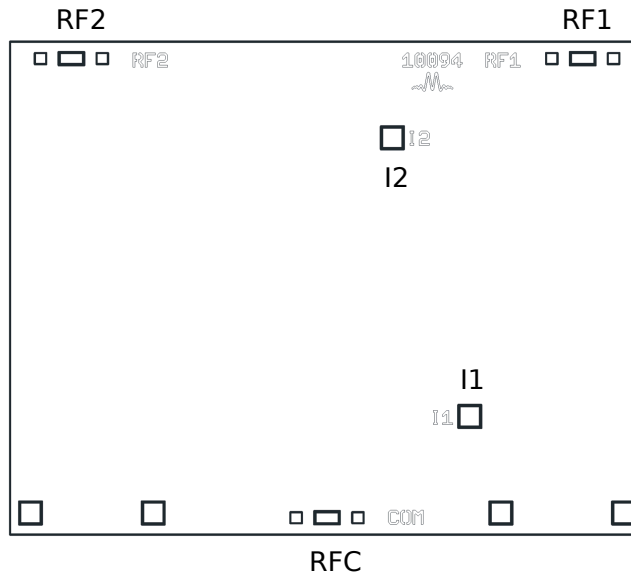

**Port Functions**

Port	Function	Description	DC Equivalent Circuit
GND	Ground	DC and RF ground is provided through the backside of the die. The die should be connected to a DC/RF ground with high thermal and electrical conductivity.	-
I1	VCTRL1	I1 is the control input pad for port RF1. Control voltages applied to this pad and the I2 pad will result in the active switch path being turned ON or OFF as described in the Application Information section of the datasheet. Nominal positive and negative control voltage for this port are +5V and -5V respectively. The bias circuit attached to this pad should be capable of sourcing or sinking at least 10mA of DC control current.	-
I2	VCTRL2	I2 is the control input pad for port RF2. Control voltages applied to this pad and the I1 pad will result in the active switch path being turned ON or OFF as described in the Application Information section of the datasheet. Nominal positive and negative control voltage for this port are +5V and -5V respectively. The bias circuit attached to this pad should be capable of sourcing or sinking at least 10mA of DC control current.	-
RF1	Input/Output 1	RF port 1 of the device, impedance looking into this port matches RFC load impedance in the ON state. This port is reflective and shorted to GND in the OFF state. This port is internally DC shorted to GND and should have an external DC block installed if DC exists on the RF1 line.	-
RF2	Input/Output 2	RF port 2 of the device, impedance looking into this port matches RFC load impedance in the ON state. This port is reflective and shorted to GND in the OFF state. This port is internally DC shorted to GND and should have an external DC block installed if DC exists on the RF2 line.	-
RFC	Common	RF common port of the device. The input impedance of this port is determined by the RF output port terminations. Output ports should be connected to a 50 Ohm load for normal operation. This port is internally DC shorted to GND and should have an external DC block installed if DC exists on the RFC line.	-

## Specifications

### Absolute Maximum Ratings

The Absolute Maximum Ratings indicate limits beyond which damage may occur to the device. If these limits are exceeded, the device may become inoperable or have a reduced lifetime.

Parameter	Maximum Rating	Unit
Max DC on any RF port <sup>1</sup>	0	V
Maximum Operating Temperature	100	°C
Maximum Storage Temperature	125	°C
Minimum Operating Temperature	-55	°C
Minimum Storage Temperature	-65	°C
Negative Supply Voltage	-10	V
Positive Supply Voltage	10	V

<sup>[1]</sup> RF ports are internally shorted to GND and should not have DC voltage applied.

### Package Information

Parameter	Details	Rating
Dimensions	-	3.10 x 2.40 mm

### Recommended Operating Conditions

The Recommended Operating Conditions indicate the limits, inside which the device should be operated, to guarantee the performance given in Electrical Specifications. Operating outside these limits may not necessarily cause damage to the device, but the performance may degrade outside the limits of the electrical specifications. For limits, above which damage may occur, see Absolute Maximum Ratings.

Parameter	Min	Nominal	Max	Unit
Control Voltage Low, VINL	-8	-5	-3	V
Control Voltage High, VINH	3	5	8	V
Ta Ambient Temperature	-55	25	100	°C
Control Current, IINL	-5	-10	-15	mA
Control Current, IINH	5	10	15	mA

**Electrical Specifications**

The electrical specifications apply at TA=+25 °C in a 50 Ω system. Unless otherwise noted, all specifications are for I1=±10mA, I2=±10mA and V1 and V2 = ±5V (both switch paths) with all ports terminated into 50 Ω loads.

Parameter	Test Conditions	Minimum Frequency (GHz)	Maximum Frequency (GHz)	Min	Typ	Max	Unit
Insertion Loss	I1=±10mA, I2=±10mA, V1 and V2=±5V	2	26	-	0.8	-	dB
Return Loss	I1=±10mA, I2=±10mA, V1 and V2=±5V	2	26	-	22	-	dB
Isolation, RF1 to RF2	I1=±10mA, I2=±10mA, V1 and V2=±5V	2	26	-	55	-	dB
Isolation, RFC to any non-active Port	I1=±10mA, I2=±10mA, V1 and V2=±5V	2	26	-	52	-	dB
Input P1dB	I1=±10mA, I2=±10mA, V1 and V2=±5V	2	14	-	25	-	dBm
Input IP3	Two Tones @ +12dBm, dF=1 MHz, I1=±10mA, I2=±10mA, V1 and V2=±5V	2	20	-	41	-	dBm
RF Settling Time	50% V1 and V2 to 0.1dB final RF output	2	26	-	19	-	ns
Risetime/Falltime	10-90% of RF output	2	26	-	4	-	ns
On-Time	50% V1 and V2 to 90% RF output	2	26	-	17	-	ns
Nominal RF Impedance	I1=±10mA, I2=±10mA, V1 and V2=±5V	-	-	-	50	-	Ω

**Typical Performance Plots**

Unless otherwise noted, plotted data is for  $I1=\pm 10\text{mA}$ ,  $I2=\pm 10\text{mA}$  and  $V1$  and  $V2 = \pm 5\text{V}$  (both switch paths) with all ports terminated into  $50\ \Omega$  loads.

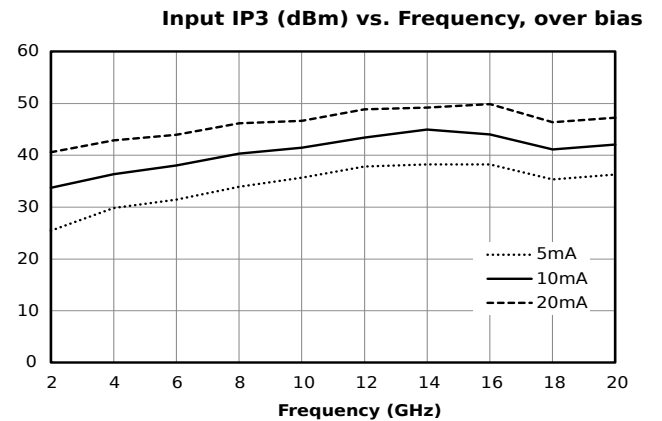
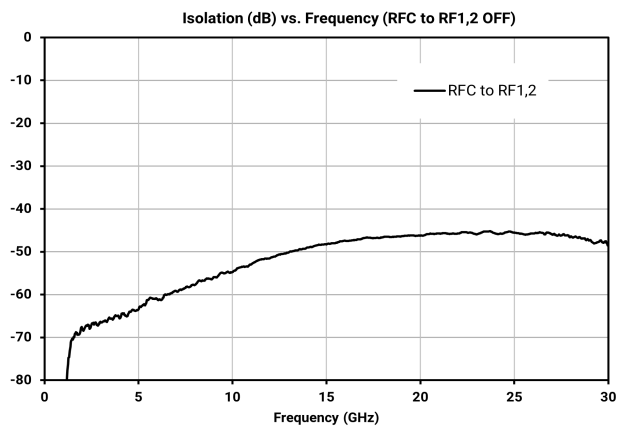
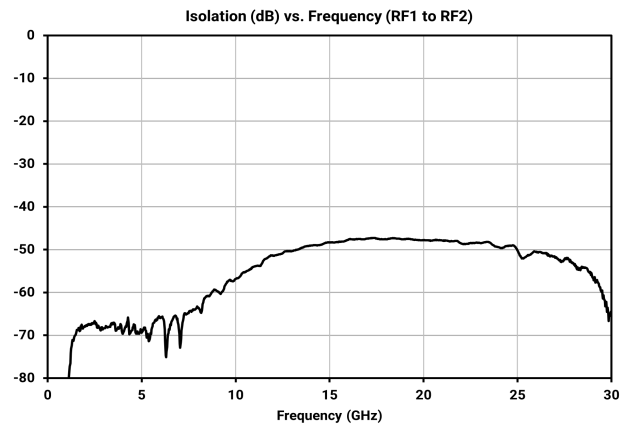
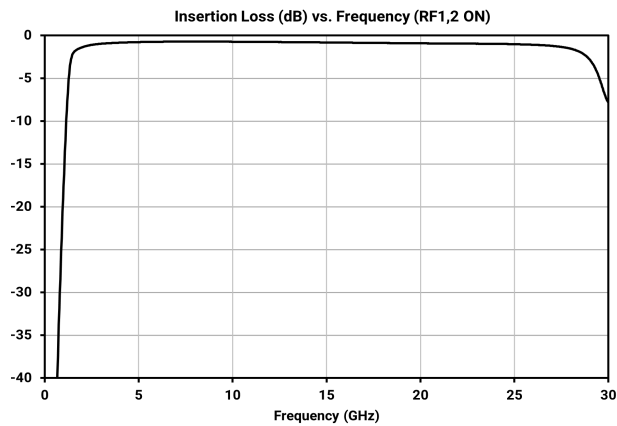
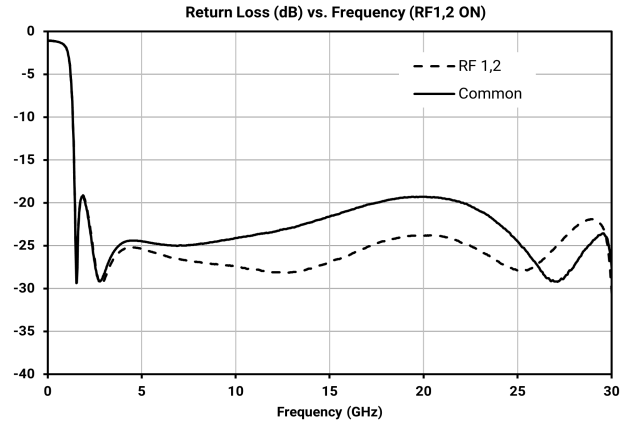
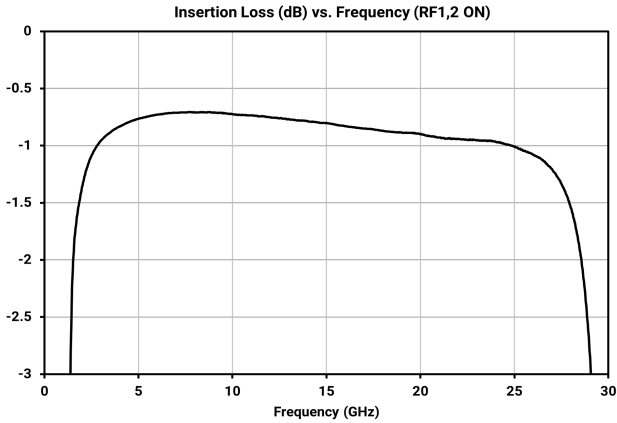

**Input P1dB vs. Frequency, over bias**

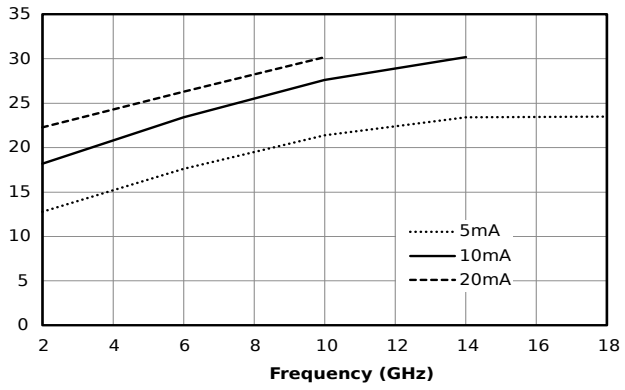

### Application Information

The MSW2-00001CH is an RF SPDT switch. This switch is a reflective design at the RF outputs, meaning these ports will appear reflective in the OFF state. All RF ports are internally DC shorted to GND and should have external DC blocks installed if DC exists on the RF lines.

The MSW2-00001CH requires both positive and negative 5V control/supply voltages, which are applied directly to the I1 and I2 pads of the die. The I1 and I2 inputs are internally bypassed, so no external bypassing is needed. The I1 and I2 inputs control the switch state as specified in the Switch Logic Table. Depending on the polarity of the applied control voltage, the DC supply must be capable of sourcing or sinking at least 10mA of control current. The control current is determined by the voltage on the I1 and I2 pins. While the nominal control voltage is  $\pm 5V$ , higher control voltages will result in increased control currents, which in turn improve switch linearity. Further details can be found in the performance plots.

I1	I2	Active Switch Path
-5V@-10mA	+5V@+10mA	RFC to RF1
+5V@+10mA	-5V@-10mA	RFC to RF2

Switch Logic Table

**Application Circuit**

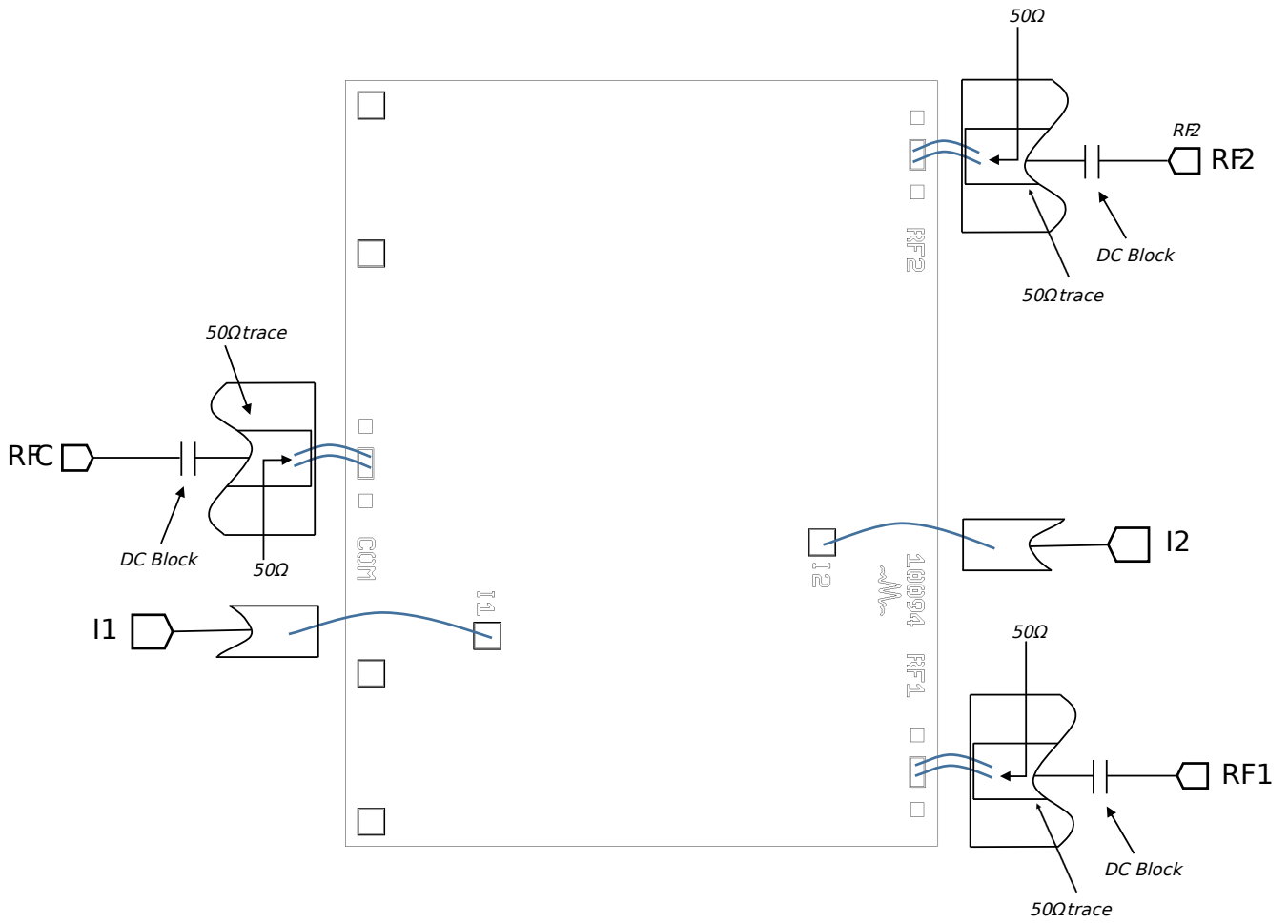

## Die Mounting Recommendations

### Mounting and Bonding Recommendations

Marki MMICs should be attached directly to a ground plane with conductive epoxy. The ground plane electrical impedance should be as low as practically possible. This will prevent resonances and permit the best possible electrical performance. Datasheet performance is only guaranteed in an environment with a low electrical impedance ground.

**Mounting** - To epoxy the chip, apply a minimum amount of conductive epoxy to the mounting surface so that a thin epoxy fillet is observed around the perimeter of the chip. Cure epoxy according to manufacturer instructions.

**Wire Bonding** - Ball or wedge bond with 0.025 mm (1 mil) diameter pure gold wire. Thermosonic wire bonding with a nominal stage temperature of 150 °C and a ball bonding force of 40 to 50 grams or wedge bonding force of 18 to 22 grams is recommended. Use the minimum level of ultrasonic energy to achieve reliable wirebonds. Wirebonds should be started on the chip and terminated on the package or substrate. Bond wire inductance will improve return loss. Bond wire inductance in the range of 30pH to 200pH will improve performance.

**Circuit Considerations** – 50 Ω transmission lines should be used for all high frequency connections in and out of the chip. Wirebonds should be kept as short as possible, with multiple wirebonds recommended for higher frequency connections to reduce parasitic inductance. In circumstances where the chip more than .001” thinner than the substrate, a heat spreading spacer tab is optional to further reduce bondwire length and parasitic inductance.

### Mechanical Data

### Outline Drawing

Download : [Outline 2D Drawing](#)

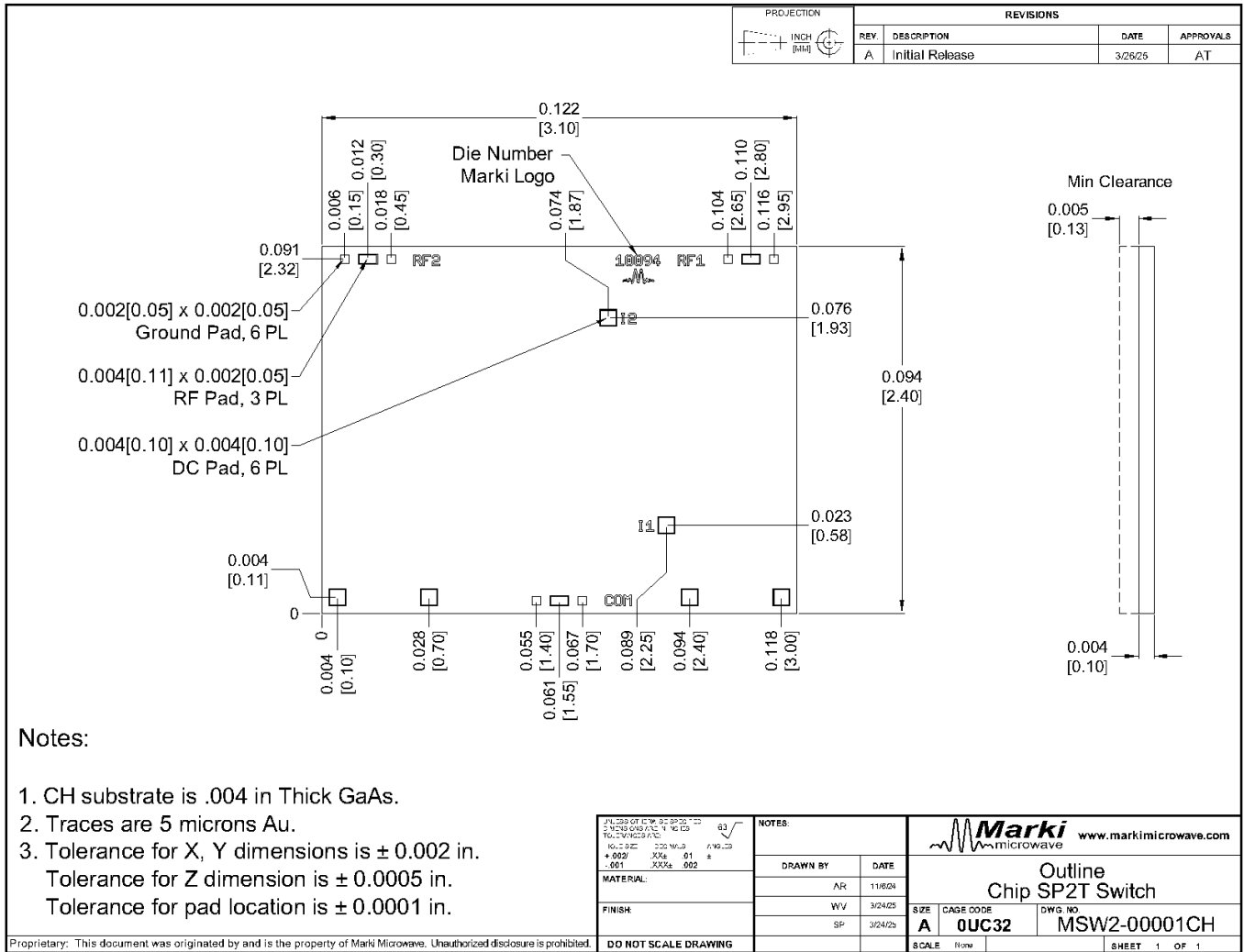

1. CH substrate is .004 in Thick GaAs.
2. Traces are 5 microns Au.
3. Tolerance for X, Y dimensions is ± 0.002 in.  
Tolerance for Z dimension is ± 0.0005 in.  
Tolerance for pad location is ± 0.0001 in.

#### **DISCLAIMER**

MARKI MICROWAVE, LLC., ("MARKI") PROVIDES TECHNICAL SPECIFICATIONS AND DATA (INCLUDING DATASHEETS), APPLICATION OR OTHER DESIGN ADVICE, WEB TOOLS, AND OTHER INFORMATION AND RESOURCES "AS IS" AND WITH ALL FAULTS. MARKI DISCLAIMS ALL WARRANTIES, EXPRESS OR IMPLIED, INCLUDING, WITHOUT LIMITATION, ANY IMPLIED WARRANTIES OF MERCHANTABILITY, FITNESS FOR A PARTICULAR PURPOSE, OR NON-INFRINGEMENT.

These resources are intended for developers skilled in the art designing with Marki products. You are solely responsible for (1) selecting the appropriate products for your application, (2) designing, validating, and testing your application, and (3) ensuring your application meets applicable standards and other requirements. Marki makes no guarantee regarding the suitability of its products for any particular purpose, nor does Marki assume any liability whatsoever arising out of your use or application of any Marki product.

Marki grants you permission to use these resources only for development of an application that uses Marki products. Other reproduction or use of these resources is strictly prohibited. No license is granted to any other Marki intellectual property or to any third-party intellectual property. Marki reserves the right to make changes to the product(s) or information contained herein without notice.

MARKI MICROWAVE and T3 MIXER are trademarks or registered trademarks of Marki Microwave, LLC. All other trademarks used are the property of their respective owners.

© 2025, Marki Microwave, LLC