

ADM-8624PSM

0.2 - 20 GHz High Dynamic Range Gain Block

DEVICE OVERVIEW

General Description

The ADM-8624PSM is a high-linearity, low noise amplifier capable of providing 11.5 dB gain and +25 dBm OIP3 across a broad 0.2-20 GHz bandwidth. The amplifier's low power consumption, high dynamic range and size make it an ideal choice for RF front end, low SWaP applications. Compared to the sister ADM-8475PSM, the ADM-8624PSM has higher gain and lower noise. The ADM-8475PSM has flatter gain and lower return loss. The ADM-8624PSM is available in a compact 1.3 x 2 mm DFN package.

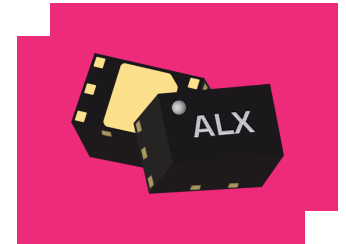

[Download s-parameters here](#)

Features

- 11.5 dB flat gain response
- +25 dBm output IP3
- 2.8 dB noise figure
- No negative bias required

Applications

- Mobile test and measurement equipment
- Radar and satellite communications
- 5G transceivers

Functional Block Diagram

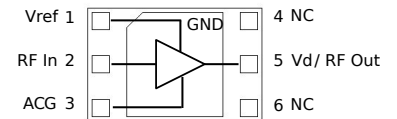

Part Ordering Options

| Part Number | Description | Package | Green Status | Product Lifecycle | Export Classification |
|---------------|--|---------|---------------|-------------------|-----------------------|
| ADM-8624PSM | 0.2 - 20 GHz High Dynamic Range Gain Block | DFN | REACH RoHS | Released | EAR99 |
| EVB-ADM-8624P | Evaluation Board, 0.2 - 20 GHz High Dynamic Range Gain Block Amplifier | EVB | REACH RoHS | Released | EAR99 |

Table Of Contents

- **Device Overview**
 - General Description
 - Features
 - Applications
 - Functional Block Diagram
- **Port Configuration and Functions**
 - Port Diagram
 - Port Functions
- **Revision History**
- **Specifications**
 - Absolute Maximum Ratings
 - Package Information
 - Recommended Operating Conditions
 - Sequencing Requirements
 - Electrical Specifications
 - Typical Performance Plots
- **Operation**
 - Application Information
 - Application Circuit
 - Application Circuit Description
- **Mechanical Data**
 - Outline Drawing
- **Footprint Image**
- **Evaluation Board**
 - Evaluation Board - Typical Performance Plots
 - Evaluation Board Outline Drawing

Revision History

| Revision Code | Revision Date | Comment |
|---------------|---------------|---------------------------|
| - | 2023-06-01 | Initial Datasheet Release |

Port Configuration and Functions

Port Diagram

A port diagram of the ADM-8624PSM QFN package is shown below (X-ray view from the top). The pin functions are detailed in section 2.2 of this datasheet.

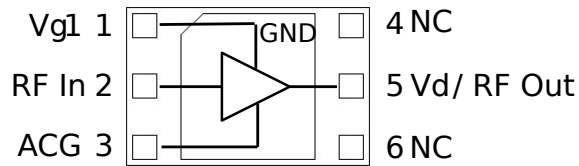

Port Functions

| Port | Function | Description | Equivalent Circuit for Package |
|---------|-------------|---|--------------------------------|
| Paddle | Gnd | Package ground paddle must be connected to a DC/RF ground potential with high thermal and electrical conductivity | - |
| Pin 1 | Vg1 | Pin 1 provides DC bias to the amplifier. Placement of an external series bias resistor allows this pin to be supplied by the same supply line providing 5V to Pin 5. Device drain current will change proportional to the current flowing into this pin. See application section for more details. | - |
| Pin 2 | RF Input | Pin 2 is the RF Input port of the amplifier. It is internally RF matched to 50 Ω and requires an external DC blocking cap. | - |
| Pin 3 | ACG | Pin 3 should be AC grounded using a series RC network. See application section for details. DO NOT DC GROUND THIS PIN. | - |
| Pin 4,6 | NC | Pin 4 and Pin 6 are internally no-connects and should be connected to DC/RF ground. | - |
| Pin 5 | RF Out / Vd | Pin 5 is the RF Output port and is also the Vd port providing the main power supply to the amplifier. This pin is DC coupled and requires an external bias-T or discrete choke and DC blocking capacitor. This port is RF matched to 50 Ω . DC voltage at this pin should be set to 5V for normal operation. | - |

Specifications

Absolute Maximum Ratings

The Absolute Maximum Ratings indicate limits beyond which damage may occur to the device. If any one of these limits are exceeded, the device may become inoperable or have a reduced lifetime. Reliability limits are individual, instantaneous catastrophic limits only. Functional operation limits are indicated below. Operation of the device at multiple absolute maximum limits or for extended periods at a single limit can cause degradation and damage to the device.

| Parameter | Maximum Rating | Unit |
|---|----------------|------|
| Drain Bias Current (Id) | 60 | mA |
| Drain Supply Voltage (Vd) | 8 | V |
| Maximum Operating Temperature for MTTF > 1E6 hours | 85 | °C |
| Maximum Storage Temperature | 125 | °C |
| Max Junction Temperature for MTTF of >1E6 hours | 175 | °C |
| Max Power Dissipation for MTTF of > 1E6 hours | 0.35 | W |
| Minimum Operating Temperature for MTTF > 1E6 hours | -40 | °C |
| Minimum Storage Temperature | -55 | °C |
| Reference Bias Current (Ig1) | 15 | mA |
| Reference Bias Voltage (Vg1) | 6.5 | V |
| RF Input Power | 20 | dBm |
| θ_{Jc} , Junction to Case Thermal Resistance | 97 | °C/W |

Package Information

| Parameter | Details | Rating |
|----------------------------|-------------------|--------------|
| Weight | Package name: DFN | 0.007g |
| Dimensions | - | 2.0 x 1.3 mm |
| Moisture Sensitivity Level | - | MSL 1 |

Recommended Operating Conditions

The Recommended Operating Conditions indicate the limits, inside which the device should be operated, to guarantee the performance given in Electrical Specifications. Operating outside these limits may not necessarily cause damage to the device, but the performance may degrade outside the limits of the electrical specifications. For limits, above which damage may occur, see Absolute Maximum Ratings.

| Parameter | Min | Nominal | Max | Unit |
|---|-----|---------|-----|------|
| Power Supply DC Voltage (Vd) | 4 | 5 | 6 | V |
| Ta Ambient Temperature | -40 | 25 | 85 | °C |
| Power Supply DC Current (Idq) (No RF Input) | 40 | 40 | 40 | mA |
| Input Power for Saturation | - | 9 | - | dBm |
| Power Supply DC Voltage (Vg1) | 4 | 5 | 6 | V |

Sequencing Requirements

There is no sequencing required to power up or power down the amplifier.

Electrical Specifications

Unless otherwise specified, electrical specifications apply at TA=+25°C, Rbias = 51Ω and Vd = 5 V.

| Parameter | Test Conditions | Minimum Frequency (GHz) | Maximum Frequency (GHz) | Min | Typ | Max | Unit |
|-----------------------------------|--|-------------------------|-------------------------|-----|------|-----|------|
| DC Supply Quiescent Current (Idq) | Vd = 5 V no RF input | - | - | - | 40 | - | mA |
| Input IP2 | Vd = 5 V Idq = 40mA Pin = -18 dBm per tone, 1 MHz tone spacing | 0.2 | 20 | - | 20 | - | dBm |
| Input IP3 | Vd = 5 V Idq = 40mA Pin = -18 dBm per tone, 1 MHz tone spacing | 0.2 | 20 | - | 14 | - | dBm |
| Input Power for Saturation | Vd = 5 V Idq = 40mA | 0.2 | 20 | - | 9 | - | dBm |
| Input Return Loss | Vd = 5 V Idq = 40mA Pin = -20 dBm | 0.2 | 20 | - | 19 | - | dB |
| Noise Figure | Vd = 5 V Idq = 40mA Pin = -20 dBm | 0.2 | 10 | - | 2.8 | - | dB |
| Noise Figure | Vd = 5 V Idq = 40mA Pin = -20 dBm | 10 | 20 | - | 3.8 | - | dB |
| Output IP2 | Vd = 5 V Idq = 40mA Pin = -18 dBm per tone, 1 MHz tone spacing | 0.2 | 20 | - | 31 | - | dBm |
| Output IP3 | Vd = 5 V Idq = 40mA Pin = -18 dBm per tone, 1 MHz tone spacing | 0.2 | 20 | - | 25 | - | dBm |
| Output P1dB | Vd = 5 V Idq = 40mA | 0.2 | 20 | - | 13.5 | - | dBm |
| Output Power | Vd = 5 V Idq = 40mA | 0.2 | 20 | - | 14.5 | - | dBm |
| Output Return Loss | Vd = 5 V Idq = 40mA Pin = -20 dBm | 0.2 | 20 | - | 17 | - | dB |
| Reverse Isolation | Vd = 5 V Idq = 40mA Pin = -20 dBm | 0.2 | 20 | - | 18 | - | dB |
| Small Signal Gain | Vd = 5 V Idq = 40mA Pin = -20 dBm | 0.2 | 20 | - | 11.5 | - | dB |

Typical Performance Plots

Performance measured on EVB-ADM-8624P. Results are de-embedded to the pin of the part.

For all plots vs bias, $R_{bias}=51\Omega$ and the voltage feeding V_{g1} is adjusted to maintain 40mA as the V_d voltage is swept.

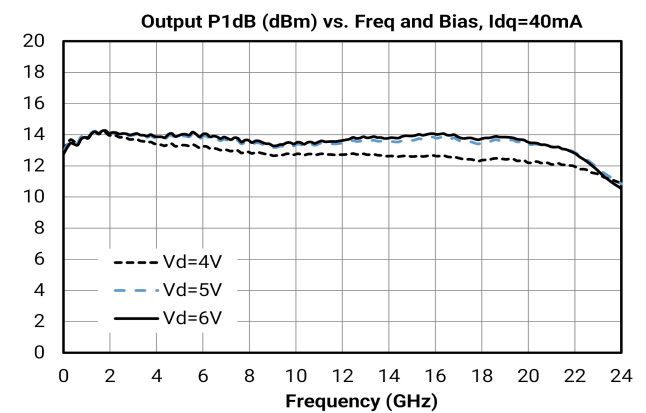
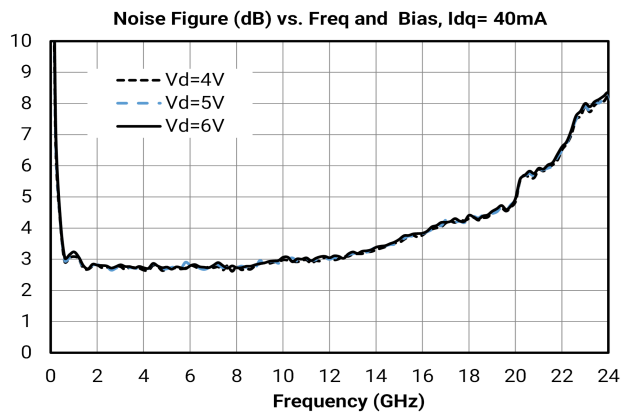
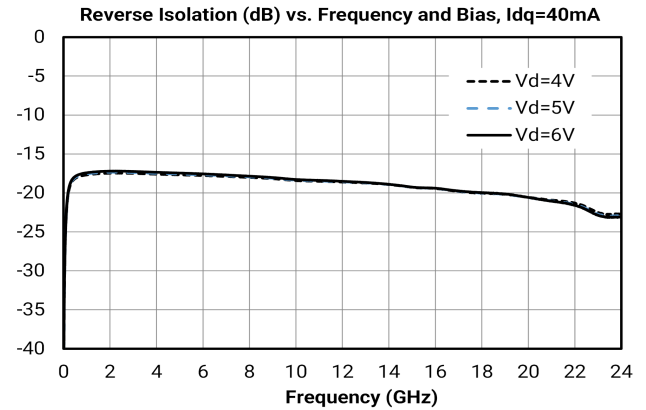
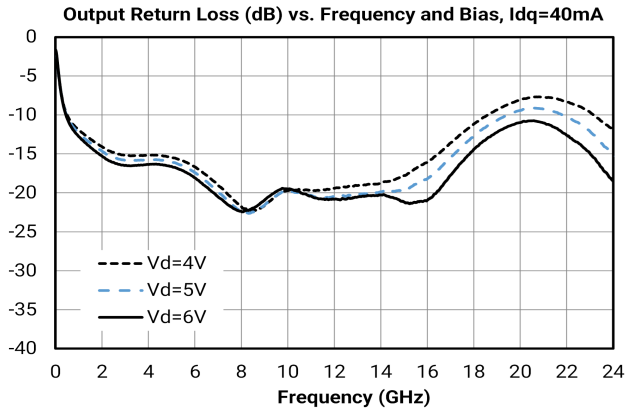
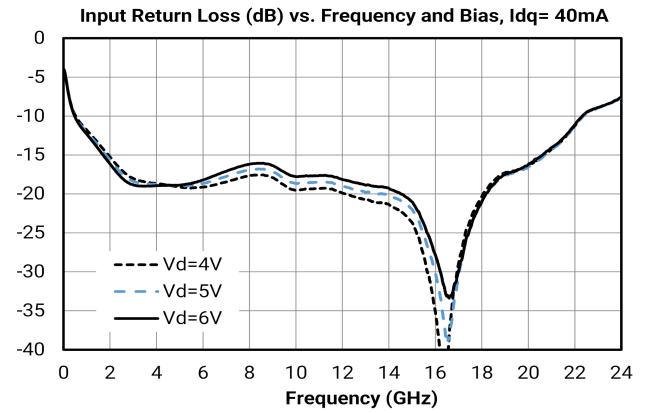
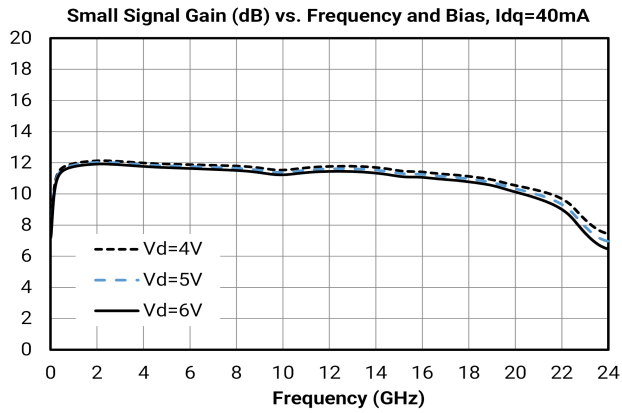

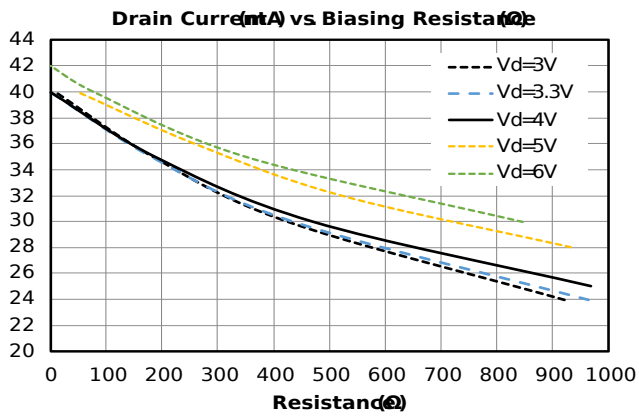

Application Information

Below is the recommended application circuit for the ADM-8624PSM.

Application Circuit

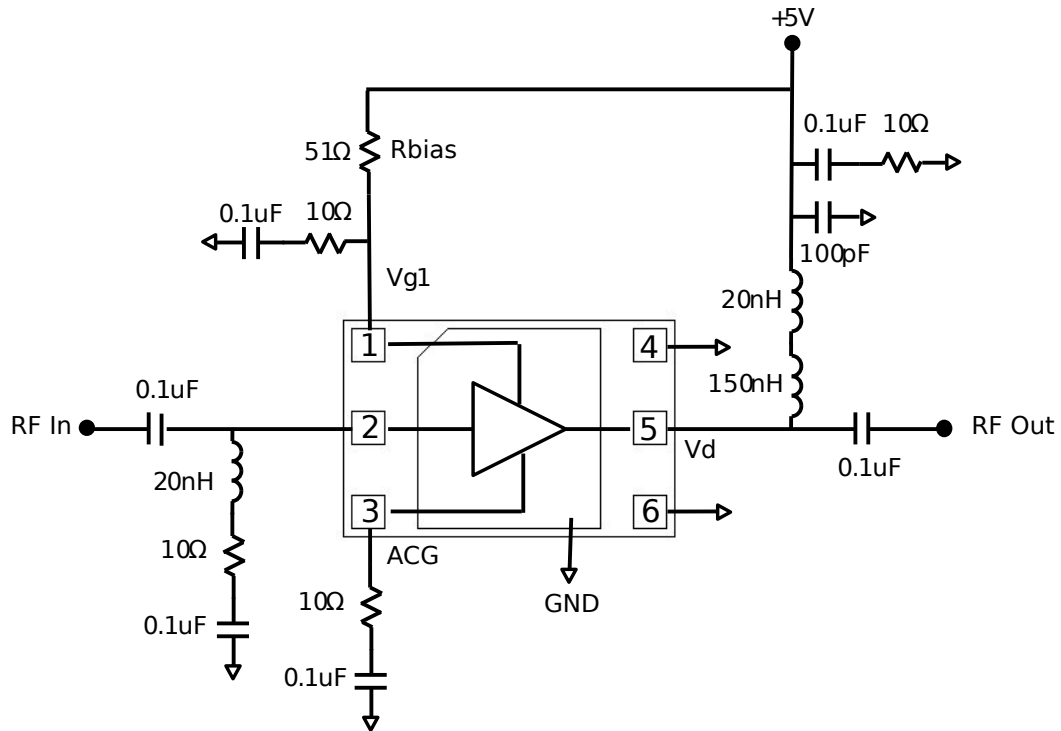

Application Circuit Description

Drain current (I_d) of the ADM-8624PSM can be adjusted by changing the value of the series resistor into Pin1 (V_{g1}). The resulting current at Pin5 (V_d /RF Out) will be proportional to the current flowing into Pin1. By carefully choosing the value of the bias resistor in series with Pin1, it's possible to power the ADM-8624PSM from a single supply. As shown above, the recommended resistor value for nominal operation with a 5V supply and $I_d=40$ mA is 51 Ohms.

The RF input pin requires a DC blocking capacitor and the external RF matching network as shown above. The matching network should be placed as close as possible to the part.

The RF Out pin doubles as a DC supply pin and requires an external choke inductor and DC blocking cap.

Supply bypassing components are recommended on all DC supply lines. Datasheet performance was measured with the values shown in the schematic above.

Package ground paddle and unused pins 4 and 6 must be connected to a DC/RF ground potential with high thermal and electrical conductivity. See the recommended landing pattern section for more details on recommended signal routing and grounding.

Mechanical Data

Outline Drawing

Download : [Outline 3D Drawing](#) | [Outline 3D STP](#)

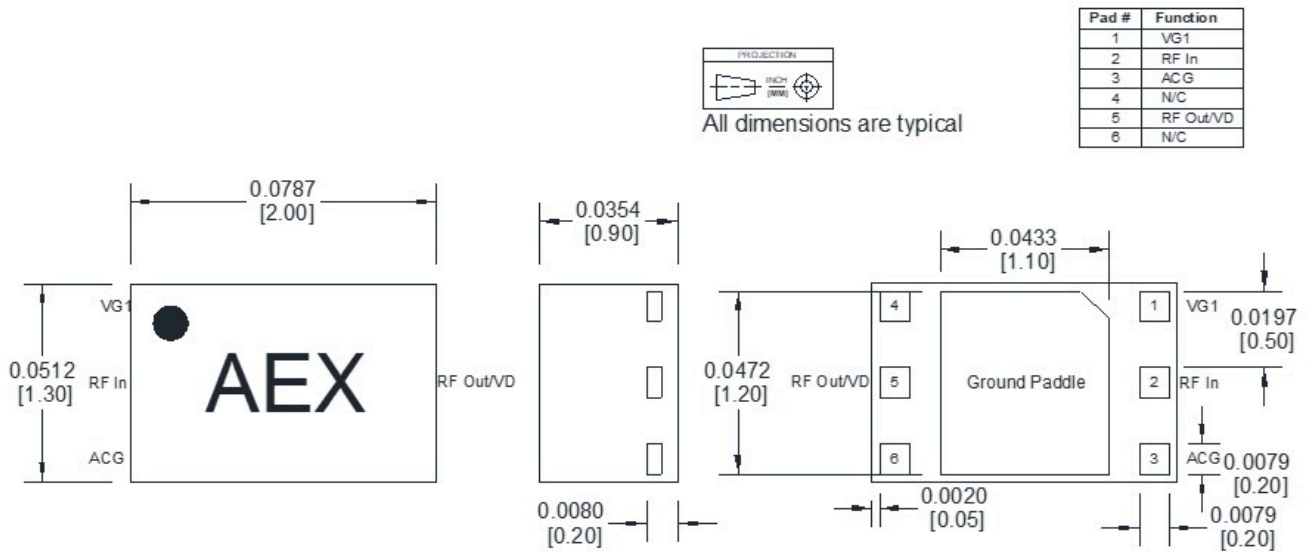

- 1) Substrate material is LCP
- 2) I/O Leads and Die Paddle is (from base to finish):
 - a. Ni: 0.5 um MIN
 - b. Pd: 0.02 um MIN
 - c. Au: 0.05 um MAX
- 3) All unconnected pins should be attached to PCB RF ground.

Footprint Image

Download : [Footprint Drawing](#)

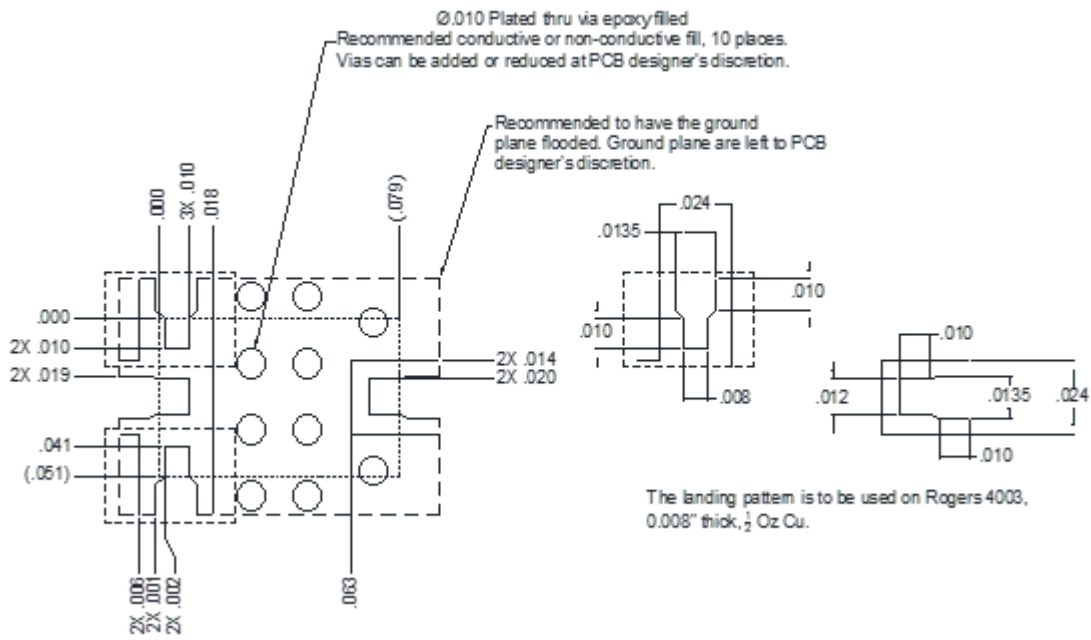

Evaluation Board - Typical Performance Plots

Measurements are taken at the evaluation board connectors.

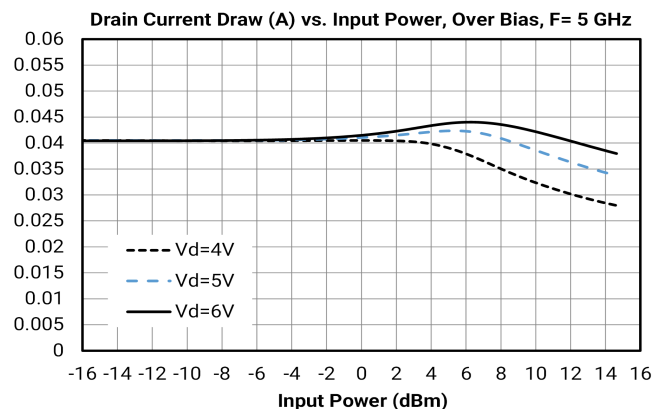
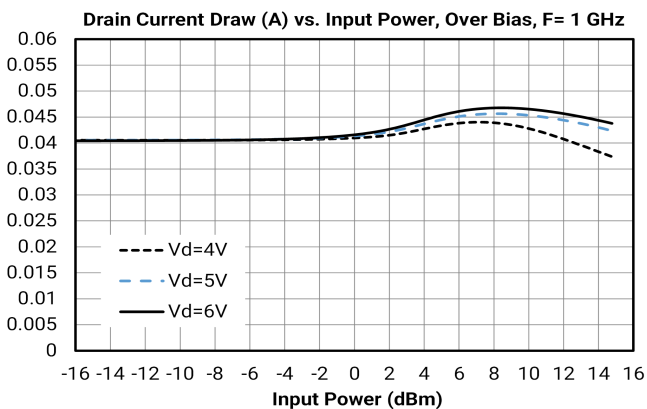
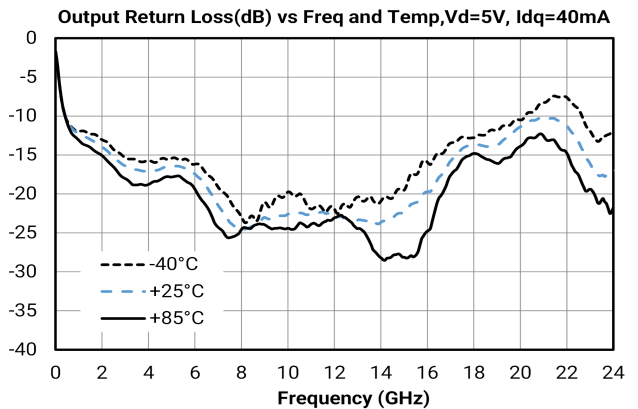
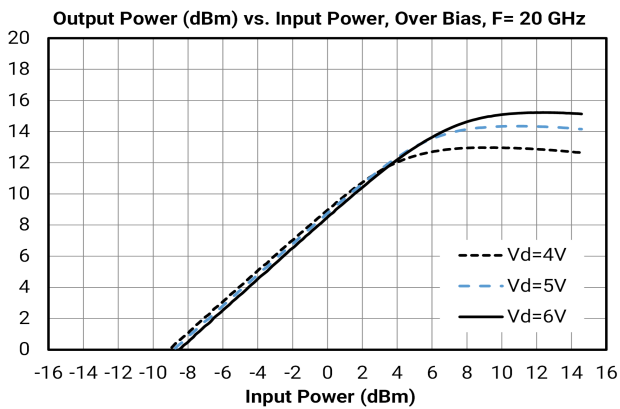
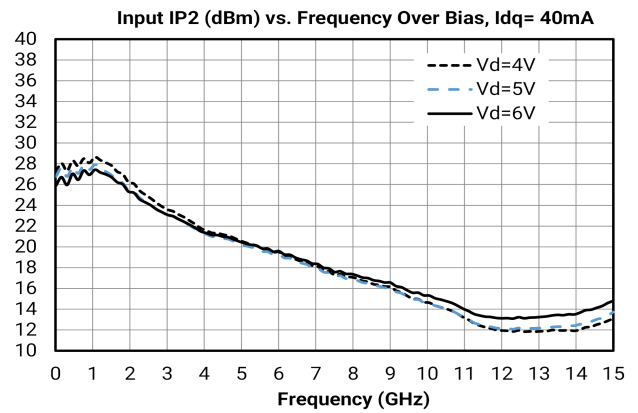
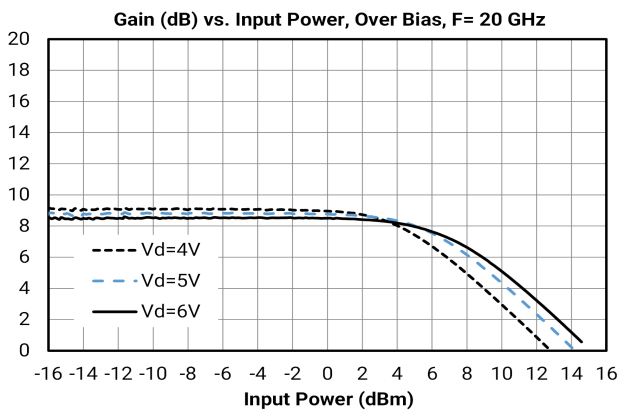
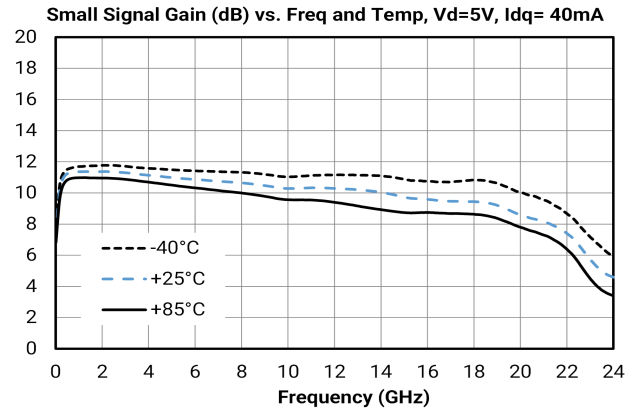
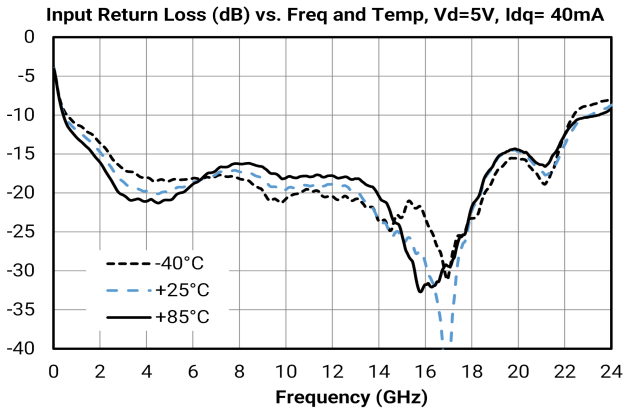

ADM-8624PSM

0.2 - 20 GHz High Dynamic Range Gain Block

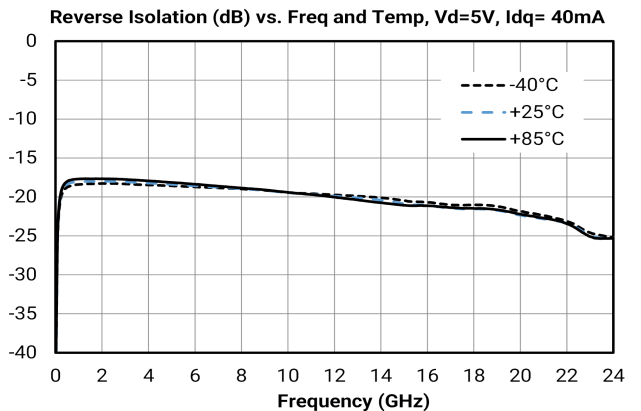
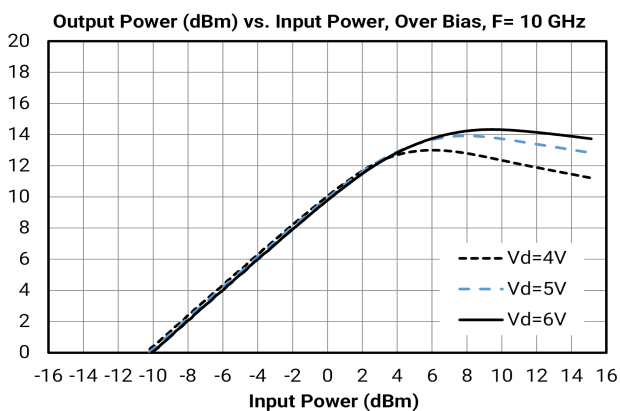
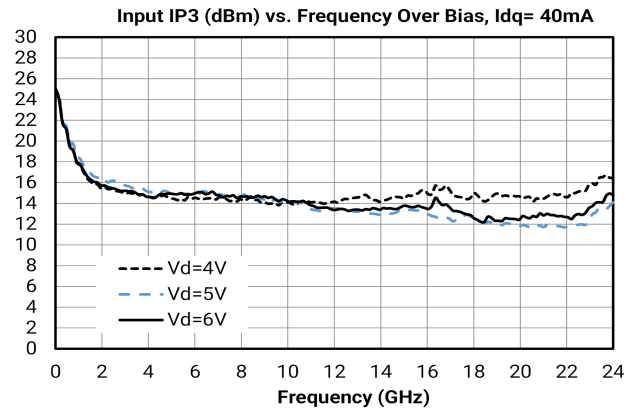
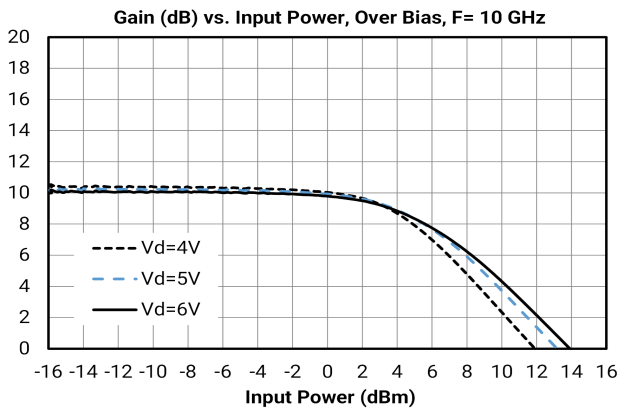
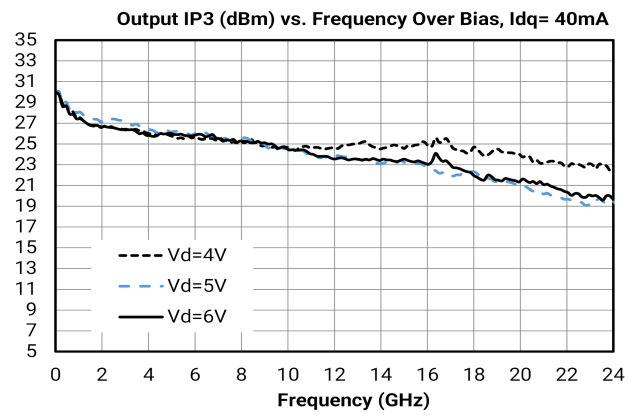
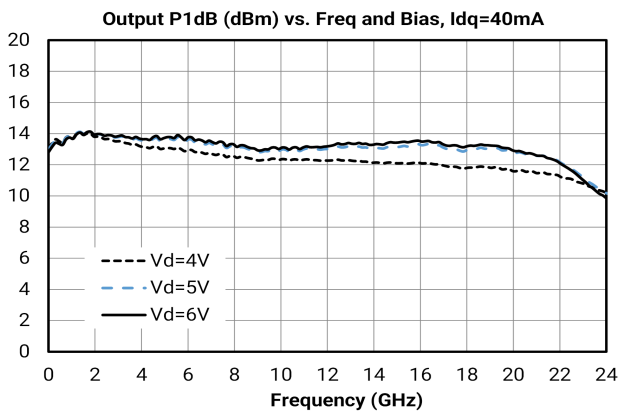
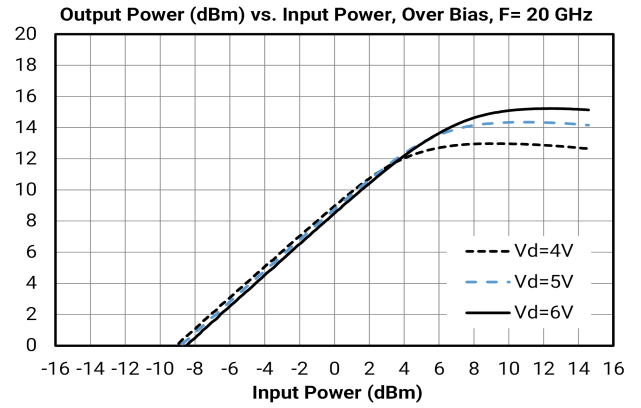
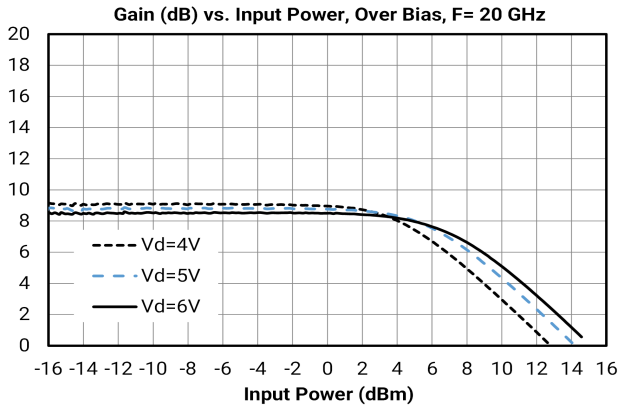

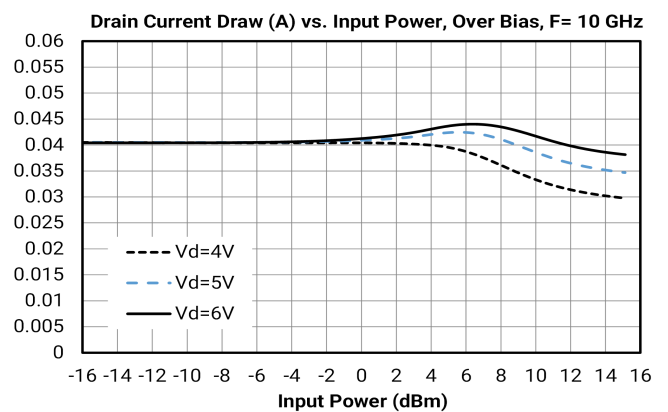
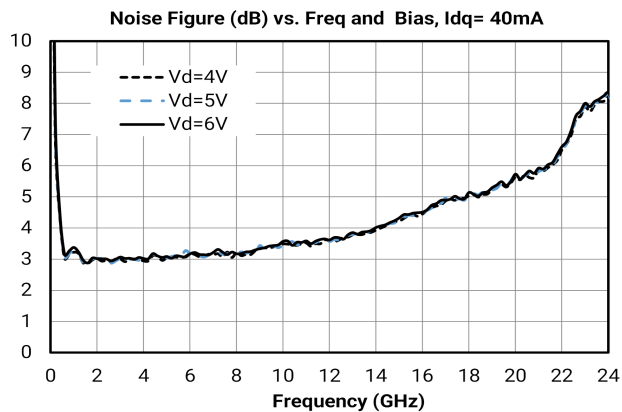
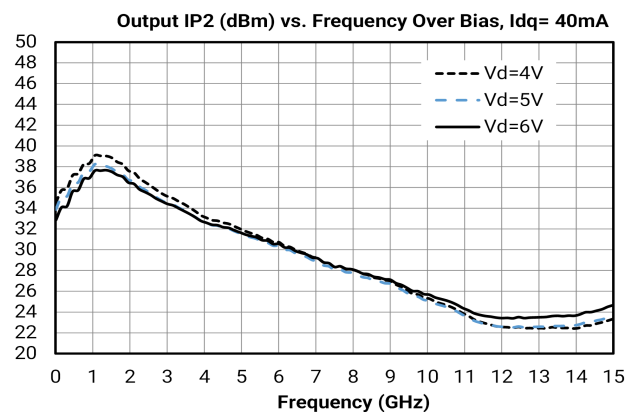
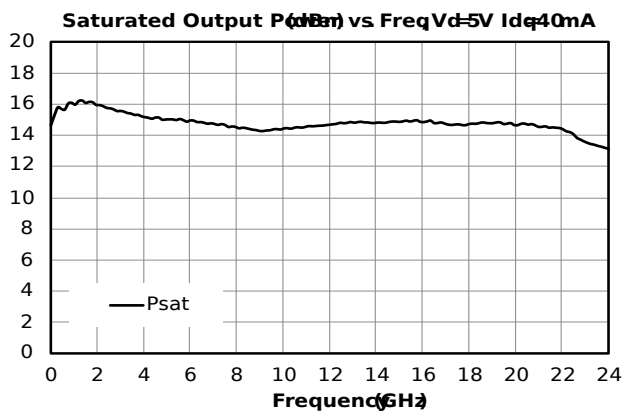
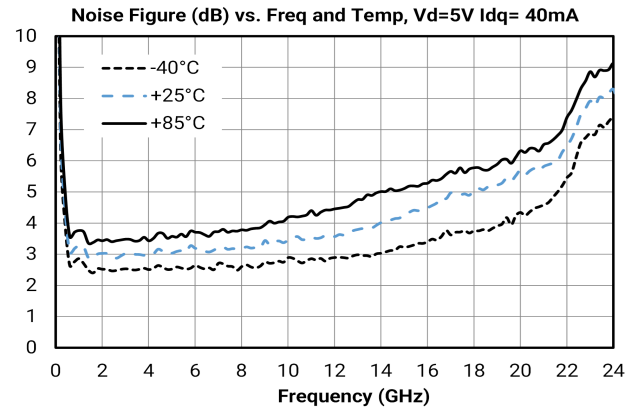
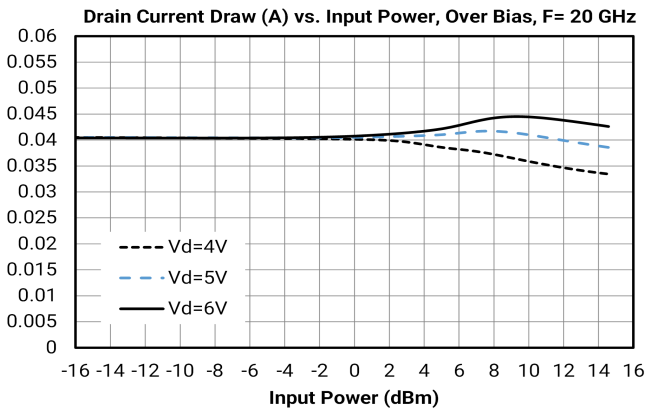

ADM-8624PSM

0.2 - 20 GHz High Dynamic Range Gain Block

Evaluation Board - Outline Drawing

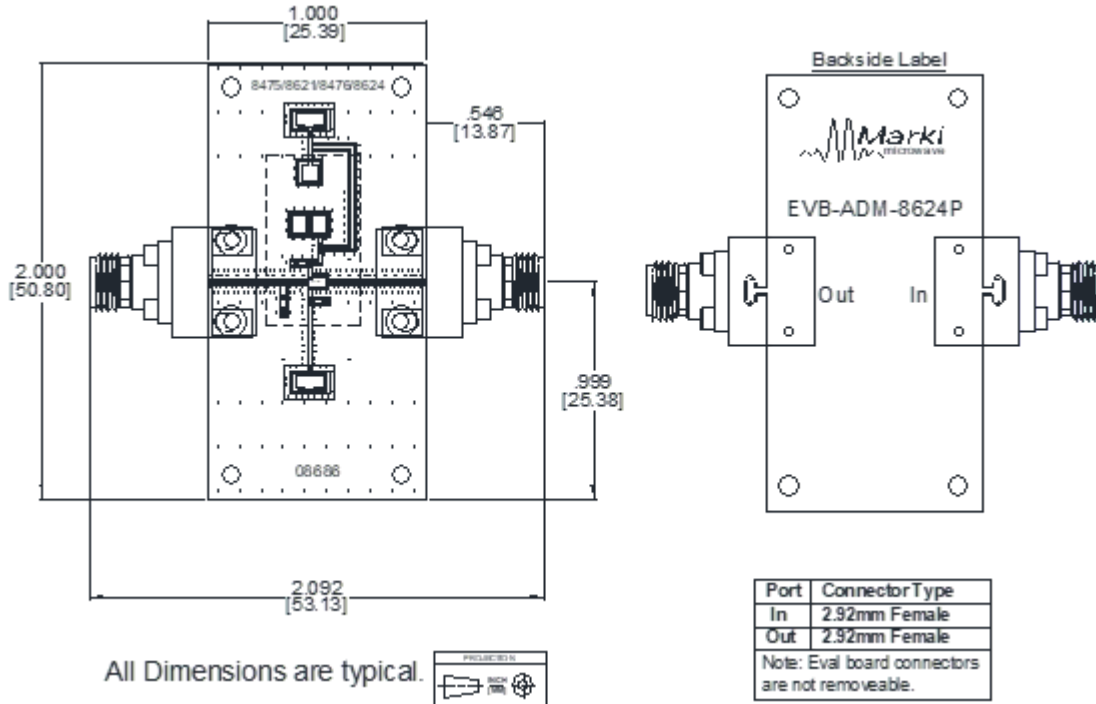

DISCLAIMER

MARKI MICROWAVE, INC., ("MARKI") PROVIDES TECHNICAL SPECIFICATIONS AND DATA (INCLUDING DATASHEETS), APPLICATION OR OTHER DESIGN ADVICE, WEB TOOLS, AND OTHER INFORMATION AND RESOURCES "AS IS" AND WITH ALL FAULTS. MARKI DISCLAIMS ALL WARRANTIES, EXPRESS OR IMPLIED, INCLUDING, WITHOUT LIMITATION, ANY IMPLIED WARRANTIES OF MERCHANTABILITY, FITNESS FOR A PARTICULAR PURPOSE, OR NON-INFRINGEMENT.

These resources are intended for developers skilled in the art designing with Marki products. You are solely responsible for (1) selecting the appropriate products for your application, (2) designing, validating, and testing your application, and (3) ensuring your application meets applicable standards and other requirements. Marki makes no guarantee regarding the suitability of its products for any particular purpose, nor does Marki assume any liability whatsoever arising out of your use or application of any Marki product.

Marki grants you permission to use these resources only for development of an application that uses Marki products. Other reproduction or use of these resources is strictly prohibited. No license is granted to any other Marki intellectual property or to any third-party intellectual property. Marki reserves the right to make changes to the product(s) or information contained herein without notice.

MARKI MICROWAVE and T3 MIXER are trademarks or registered trademarks of Marki Microwave, Inc. All other trademarks used are the property of their respective owners.

© 2023, Marki Microwave, Inc