

APM-7516PA

1 GHz – 22 GHz Low Phase Noise Amplifier

DEVICE OVERVIEW

General Description

The APM-7516 is a robust broadband distributed, low phase noise LO driver amplifier designed to provide greater than +20 dBm output power with excellent return losses and high input power handling. This amplifier uses GaAs HBT technology for low phase noise and is optimized to provide enough power to drive the LO port of an S-diode mixer from 1 GHz to 18 GHz or of an H or L diode mixer from 1 GHz to 22 GHz. This amplifier can be operated with a variety of bias conditions for both low power and high-power applications.

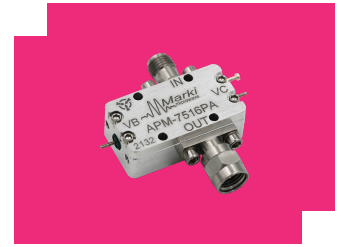

Features

- -164 dBc/Hz phase noise at 10 kHz offset frequency
- +20 dBm output power up to 18GHz
- High Linearity (+33 dBm OIP3)
- Excellent Return Losses
- +20dBm Input Power Handling
- Positive-only biasing

Applications

- Mobile test and measurement equipment
- 5G transceivers
- Driver amplifier L,H,S – diode mixers
- Radar
- SATCOM

Functional Block Diagram

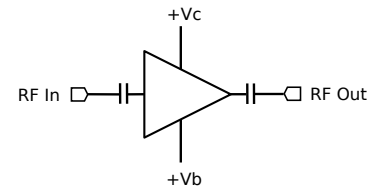

Part Ordering Options

Part Number	Description	Package	Connectors	Green Status	Product Lifecycle	Export Classification
APM-7516PA	1 GHz – 22 GHz Low Phase Noise Amplifier	PA	<u>Standard</u>	REACH RoHS	Released	EAR99

Table Of Contents

■ Device Overview

- General Description
- Features
- Applications
- Functional Block Diagram

■ Port Configuration and Functions

- Port Diagram
- Port Functions

■ Revision History

■ Specifications

- Absolute Maximum Ratings
- Fit and MTTF Table
- Package Information
- Recommended Operating Conditions
- Sequencing Requirements
- Electrical Specifications
- APM-7516PA Typical Performance Plots
- Typical Performance Plots of Marki Mixers with APM-7516PA LO Driver
- Time Domain Plots

■ Mechanical Data

- Outline Drawing

Revision History

Revision Code	Revision Date	Comment
-	2022-02-01	Initial Datasheet Release
A	2023-02-01	Added IP2 Plots
B	2026-02-13	MTTF Table Added.

Port Configuration and Functions

Port Diagram

A port diagram of the APM-7516PA is shown below.

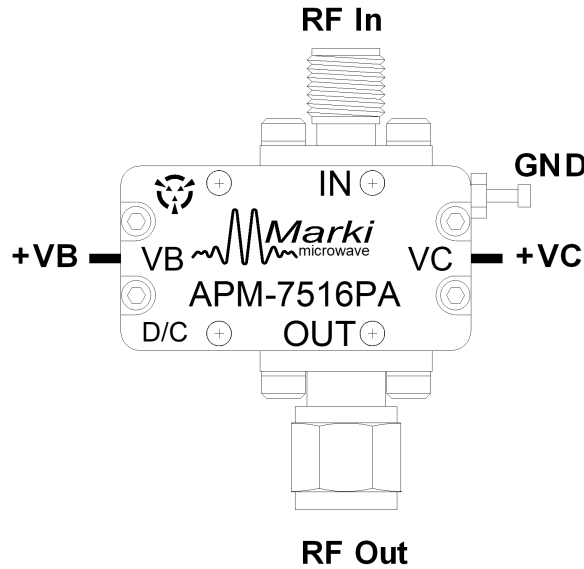

Port Functions

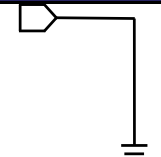
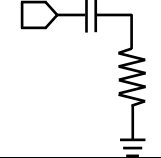
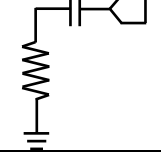
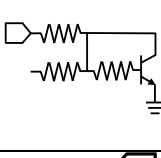
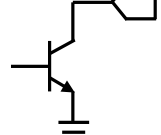
Port	Function	Connector Type	Description	DC Equivalent Circuit
GND	Ground	-	Housing or outside of the coaxial cables must be connected to a DC/RF ground potential with high thermal and electrical conductivity.	
RF In	RF Input	2.92F	This is the RF Input port of the amplifier die. It is RF matched to 50 Ω, and has built-in DC blocking capacitors.	
RF Out	RF Output	2.92M	This is the amplifier's RF Output. It is RF matched to 50 Ω and has built-in DC blocking capacitors. Must have less than 7:1 VSWR when operating.	
VB	Base Current Mirror Bias Port	-	Port VB is the DC voltage bias for the current mirror that controls collector current supplied to the amplifier. Larger voltages result in a higher current draw through port VC, effectively functioning as a gain control pin of the amplifier. See Typical Performance Plots for performance at different bias conditions.	
VC	Collector DC Supply Port	-	Port VC is the DC voltage supply that supplies the amplifier's collector current. It is connected directly to the VC port on the amplifier IC.	

Specifications

Absolute Maximum Ratings

The Absolute Maximum Ratings indicate limits beyond which damage may occur to the device. If these limits are exceeded, the device may become inoperable or have a reduced lifetime.

Parameter	Maximum Rating	Unit
Collector Positive Bias Voltage (Vc)	6	V
Continuous Power Dissipation (PDISS) (at 85 °C case temp.)	1.2	W
Maximum Operating Temperature	85	°C
Maximum Storage Temperature	150	°C
Max Junction Temperature for MTTF > 1E6 hours	125	°C
Minimum Operating Temperature	-40	°C
Minimum Storage Temperature	-65	°C
Output Load VSWR	7	-
Positive Bias Current (Ic)	240	mA
Positive DC Current Mirror Current (Ib)	15	mA
Positive DC Current Mirror Voltage (Vb)	6	V
RF Input Power	20	dBm
θJC, Junction to Ambient Thermal Resistance	33	°C/W

FIT and MTTF Table

T (°C)	λ (TIF)	MTTF (hr)	MTTF (yr)
105	2,441.45	4.10E+05	47
85	310.48	3.22E+06	368
55	8.79	1.14E+08	12,992
25	0.12	8.24E+09	941,063

Package Information

Parameter	Details	Rating
Dimensions	-	28.5 x 15 mm

Recommended Operating Conditions

The Recommended Operating Conditions indicate the limits, inside which the device should be operated, to guarantee the performance given in Electrical Specifications. Operating outside these limits may not necessarily cause damage to the device, but the performance may degrade outside the limits of the electrical specifications. For limits, above which damage may occur, see Absolute Maximum Ratings.

Parameter	Min	Nominal	Max	Unit
Positive DC Voltage (VC)	-	5	-	V
Positive DC Current Mirror Voltage (VB)	-	5	-	V
Positive DC Current Mirror Current (Ib) ¹	-	5	-	mA
Positive DC Current (Ic) ²	-	106	-	mA

[1][2] Recommended operating current conditions given without RF input applied. Please see typical performance plots for relationship between RF input power and DC current draw.

Sequencing Requirements

There is no sequencing required to power up or power down the amplifier. Amplifier must have an output load connected when operating.

Electrical Specifications

The electrical specifications apply at TA=+25°C in a 50Ω system. Min and Max limits apply only to our connectorized units and are guaranteed at TA=+25°C.

Parameter	Test Conditions	Minimum Frequency (GHz)	Maximum Frequency (GHz)	Min	Typ	Max	Unit
Current Consumption	5V/4V	-	-	-	74	-	mA
Current Consumption	5V/5V	-	-	-	106	-	mA
Current Consumption	5V/6V	-	-	-	141	-	mA
Current Mirror, Ib	5V/4V	-	-	-	4	-	mA
Current Mirror, Ib	5V/5V	-	-	-	5	-	mA
Current Mirror, Ib	5V/6V	-	-	-	7	-	mA
Input IP3	5V/5V, -15 dBm Input Power	1	22	-	21	-	dBm
Input Power for Saturation	5V/5V	1	22	-	12	-	dBm
Input Return Loss	5V/5V bias, -15 dBm Input Power	1	22	-	18	-	dB
Noise Figure	5V/5V bias, -30 dBm Input Power	1	22	-	5.1	-	dB
Output IP3	5V/5V, -15 dBm Input Power	1	22	-	33	-	dBm
Output P1dB	5V/5V	1	22	-	18	-	dBm
Output Return Loss	5V/5V bias, -15 dBm Input Power	1	22	-	20	-	dB
Phase Noise @ 10 kHz Offset	+13 dBm Input power	4	4	-	-164	-	dBc/Hz
Reverse Isolation	5V/5V bias, -15 dBm Input Power	1	22	-	34	-	dB
Saturated Output Power	5V/5V bias, P5dB	15	22	-	20	-	dBm
Saturated Output Power	5V/5V bias, P5dB	1	3	-	23	-	dBm
Saturated Output Power	5V/5V bias, P5dB	3	15	19	23	-	dBm
Small Signal Gain	5V/5V bias, -15 dBm Input Power	15	22	-	11	-	dB
Small Signal Gain	5V/5V bias, -15 dBm Input Power	1	3	-	12	-	dB
Small Signal Gain	5V/5V bias, -15 dBm Input Power	3	15	10	12.5	-	dB

APM-7516PA

1 GHz – 22 GHz Low Phase Noise Amplifier

APM-7516PA Typical Performance Plots

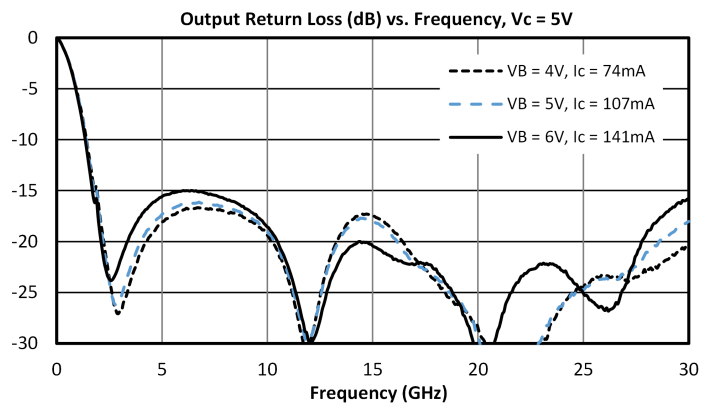
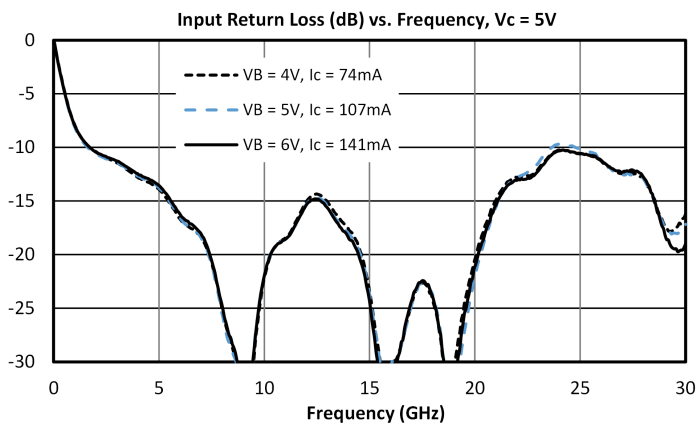
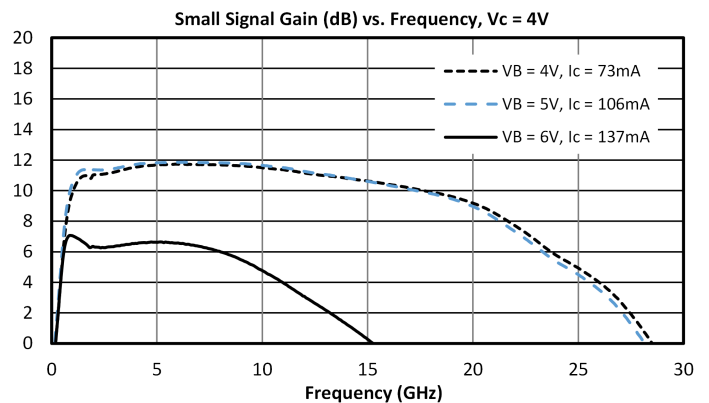
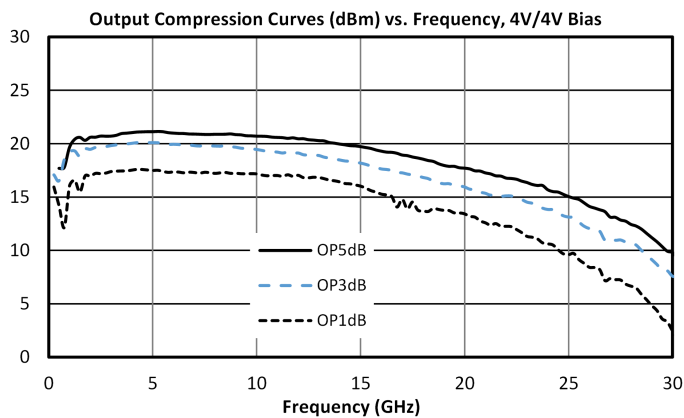
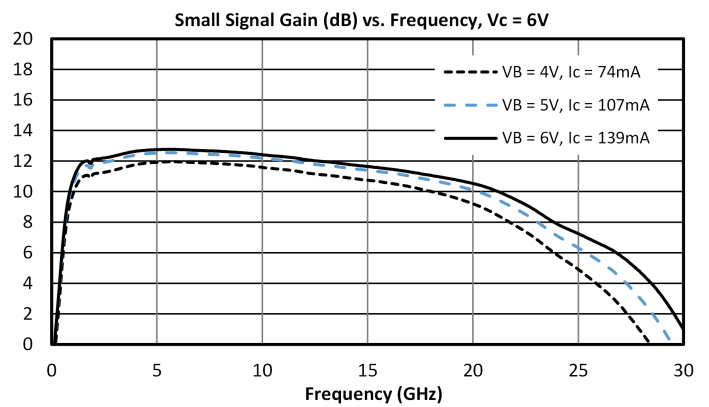
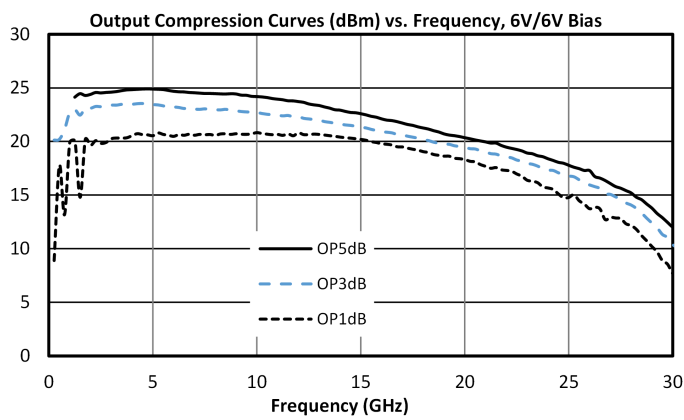
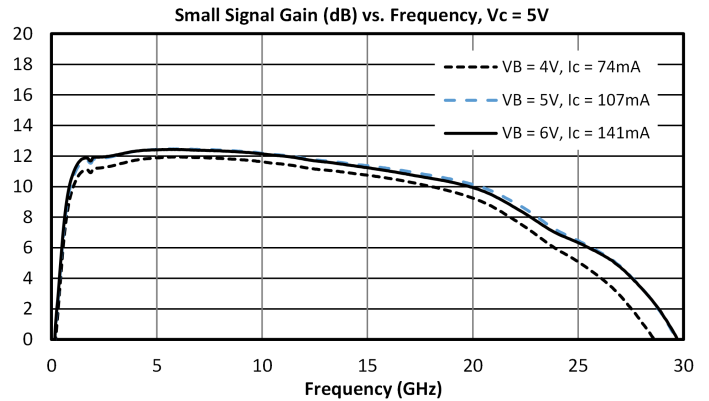
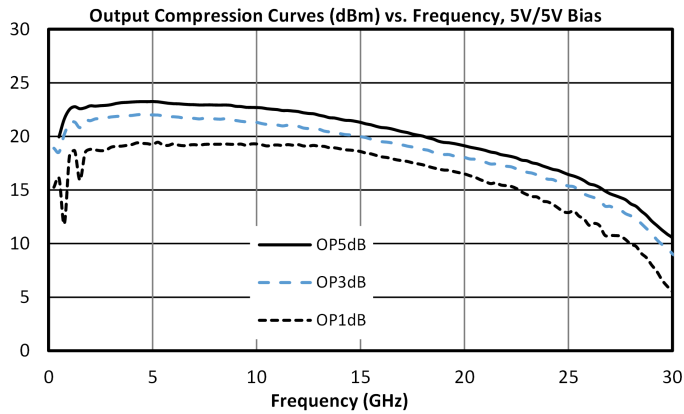

APM-7516PA

1 GHz – 22 GHz Low Phase Noise Amplifier

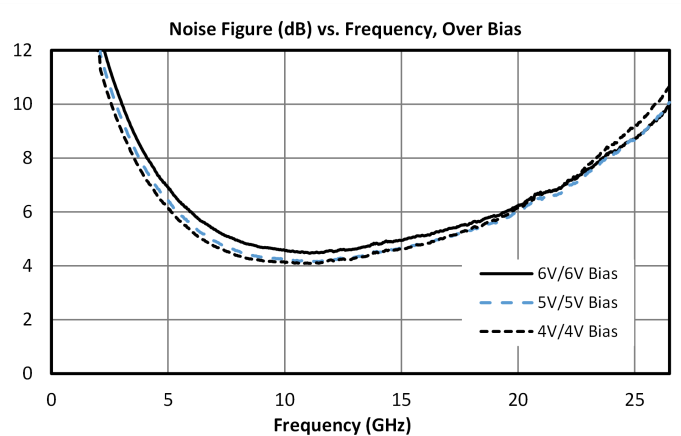
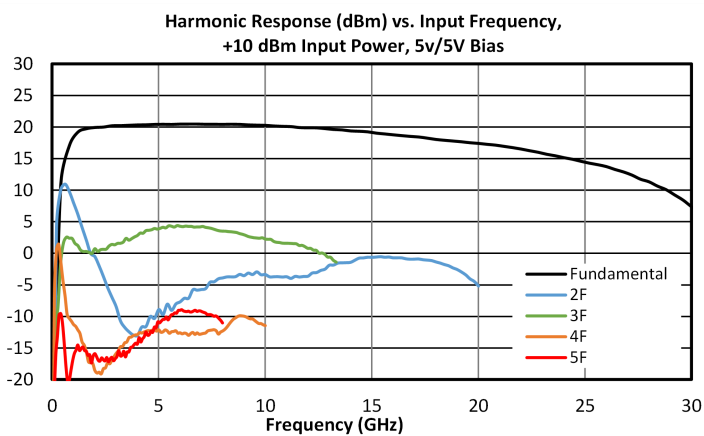
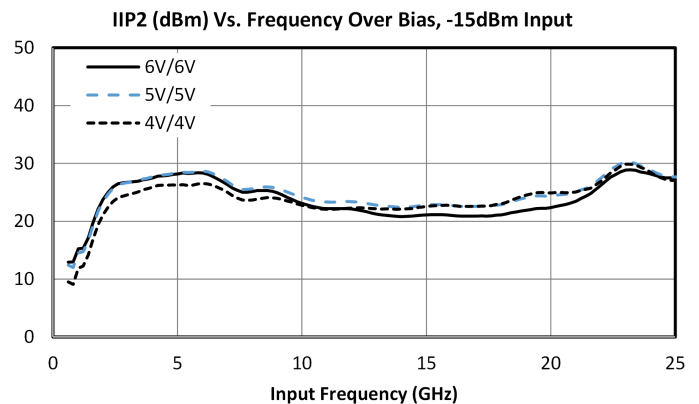
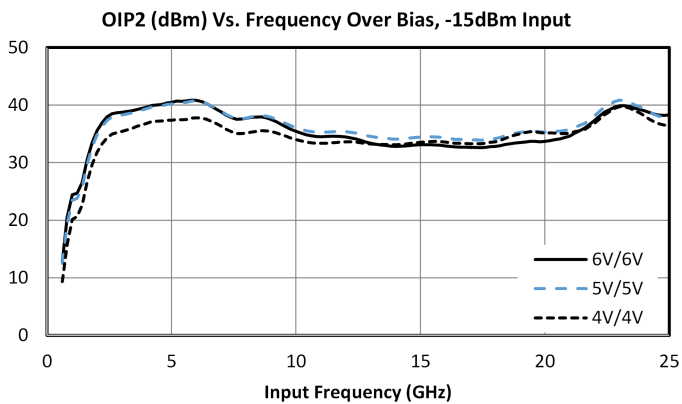
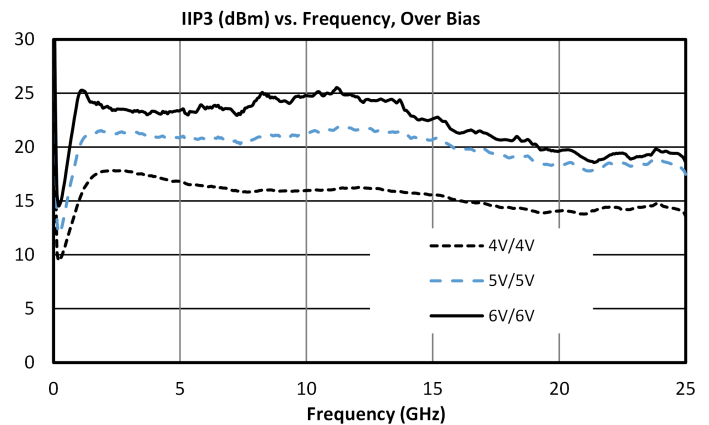
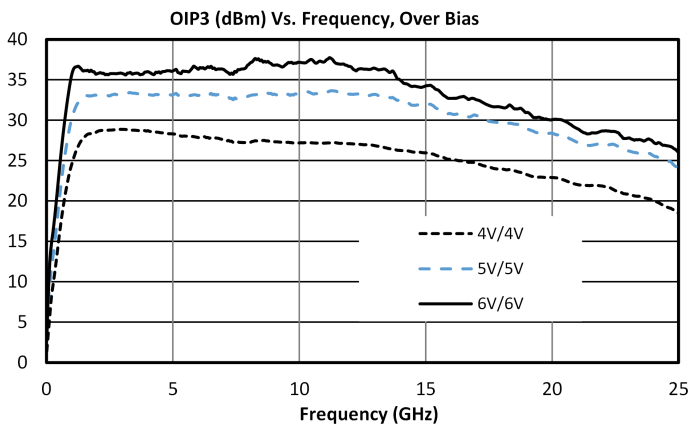
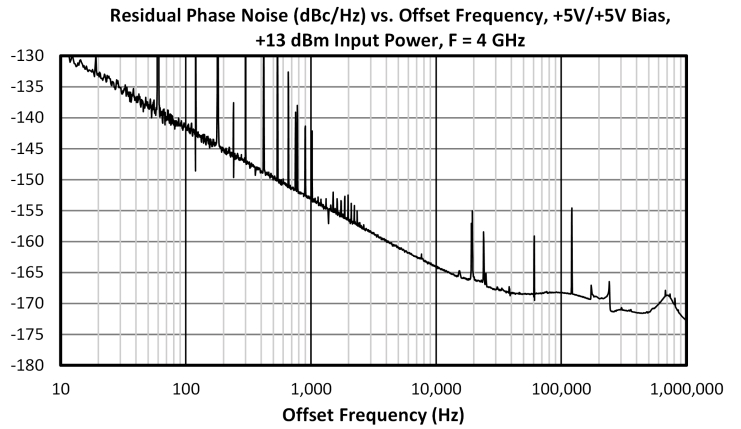
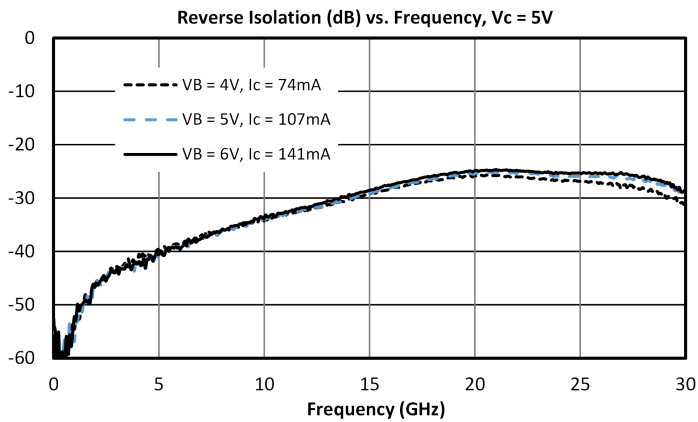

APM-7516PA

1 GHz – 22 GHz Low Phase Noise Amplifier

Output Power (dBm) vs. Frequency, Over Temperature, +10dBm Input Power, 5V/5V Bias

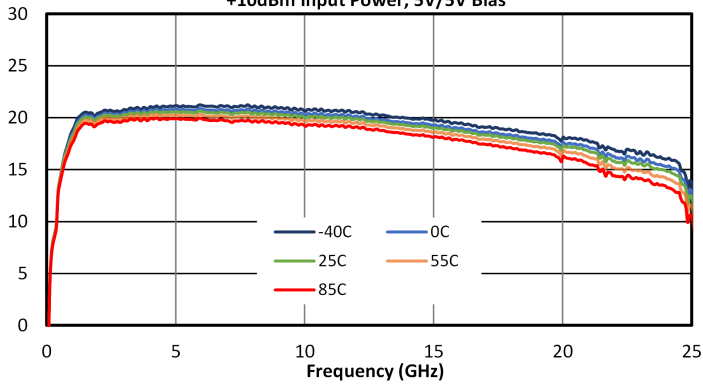

Small Signal Gain (dB) vs. Frequency, Over Temperature, 5V/5V Bias

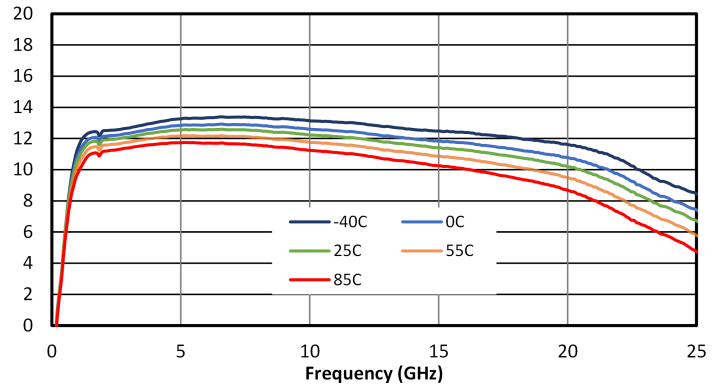

Output Power (dBm), Gain (dB), and PAE (%) vs. Input Power, F = 5 GHz, 5V/5V Bias

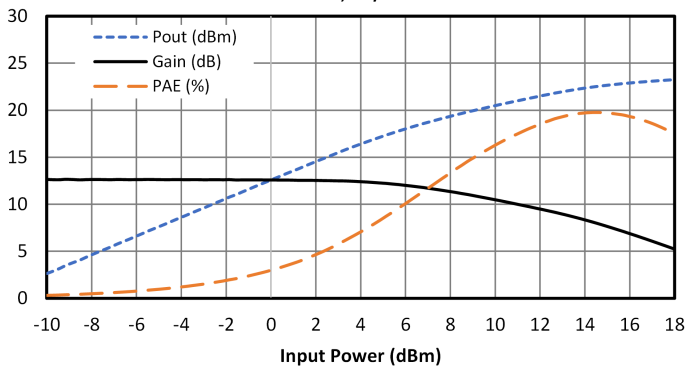

Output Power (dBm), Gain (dB), and PAE (%) vs. Input Power, F = 10 GHz, 5V/5V Bias

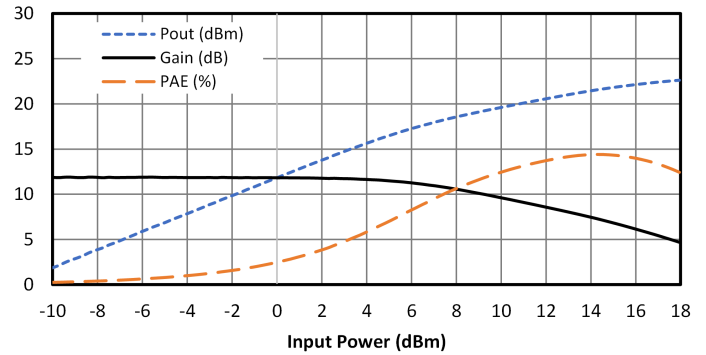

Output Power (dBm), Gain (dB), and PAE (%) vs. Input Power, F = 15 GHz, 5V/5V Bias

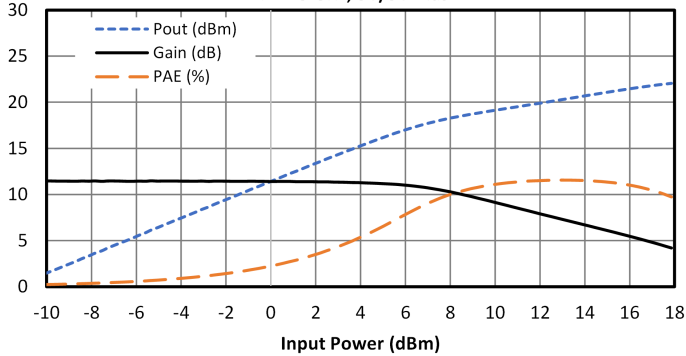

Collector Current (mA) vs. RF Input Power, Over Frequency, 5V/5V Bias

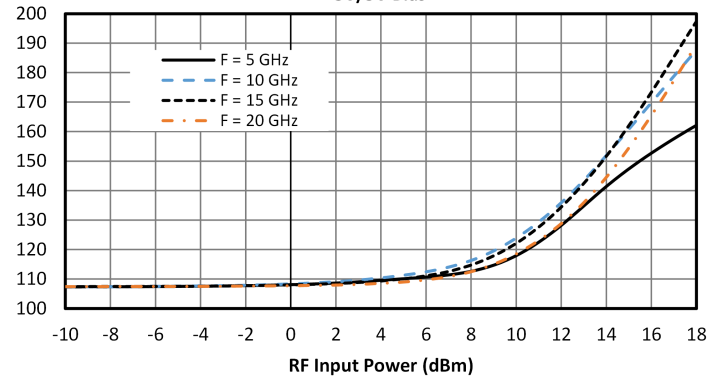

Ic, Ib (mA) vs. Vb (Vc = 5V)

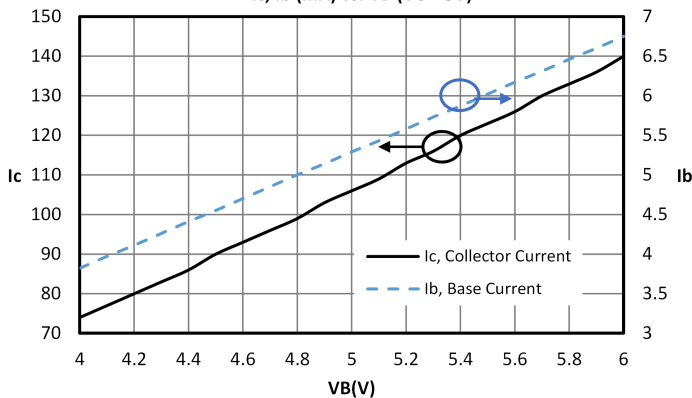

APM-7516PA

1 GHz – 22 GHz Low Phase Noise Amplifier

Typical Performance Plots of Marki Mixers with APM-7516PA LO Driver

MM1-0626S Config A Conv. Loss (dB) vs. Frequency, APM-7516PA LO Driver, 5V/5V Bias, 91 MHz IF Freq.

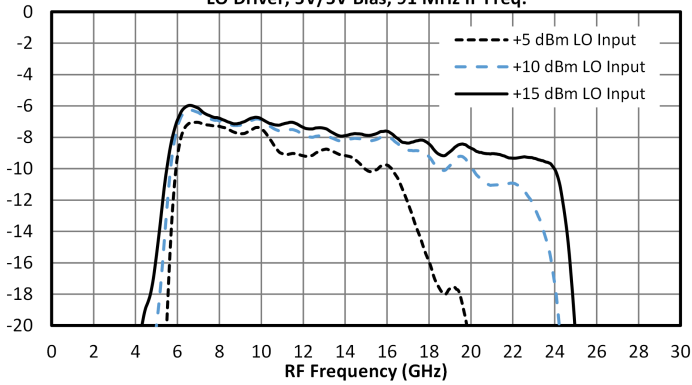

MM1-0626S IIP3 (dBm) vs. Frequency, APM-7516PA LO Driver, 5V/5V Bias, 91 MHz IF Freq.

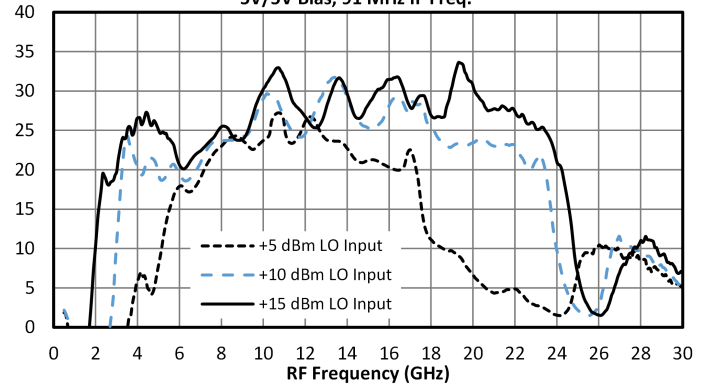

MM1-0222H Config A Conv. Loss (dB) vs. Frequency, APM-7516PA LO Driver, 5V/5V Bias, 91 MHz IF Freq.

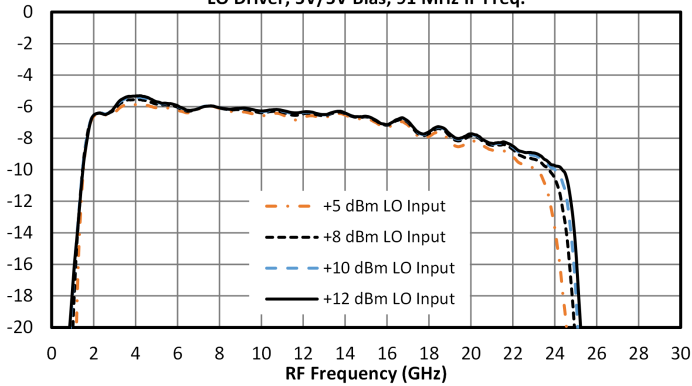

MM1-0222H IIP3 (dBm) vs. Frequency, APM-7516PA LO Driver, 5V/5V Bias, 91 MHz IF Freq.

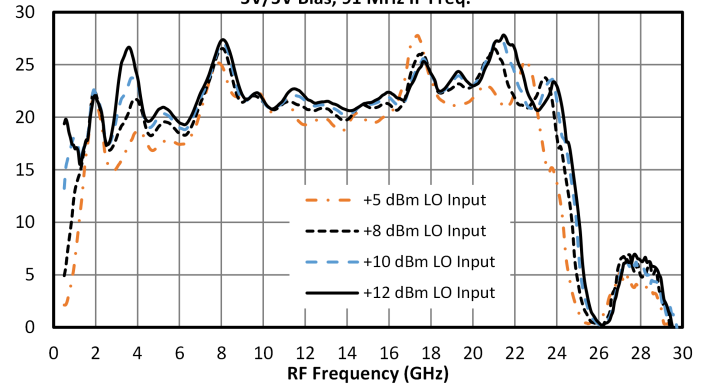

MM1-0312S Config A Conv. Loss (dB) vs. Frequency, APM-7516PA LO Driver, 5V/5V Bias, 91 MHz IF Freq.

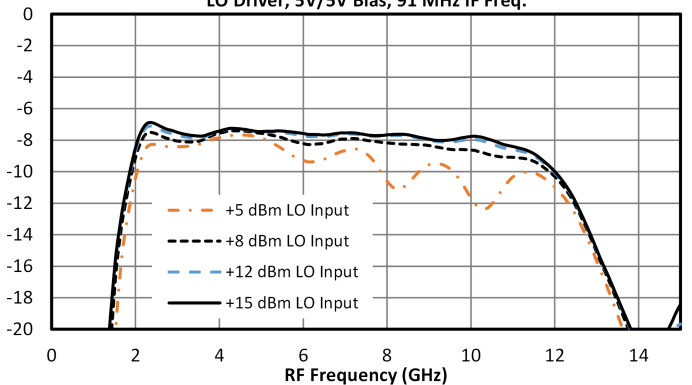

MM1-0312S IIP3 (dBm) vs. Frequency, APM-7516PA LO Driver, 5V/5V Bias, 91 MHz IF Freq.

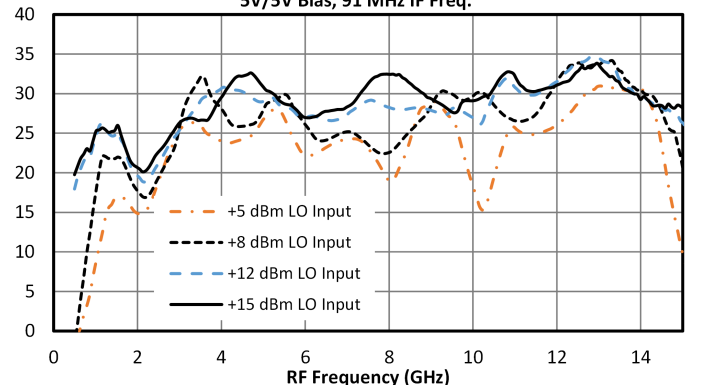

APM-7516PA

1 GHz – 22 GHz Low Phase Noise Amplifier

Time Domain Plots

Output Waveform (V) vs. Time,
F = 2 GHz, +5V/+5V Bias, +10 dBm Input Power

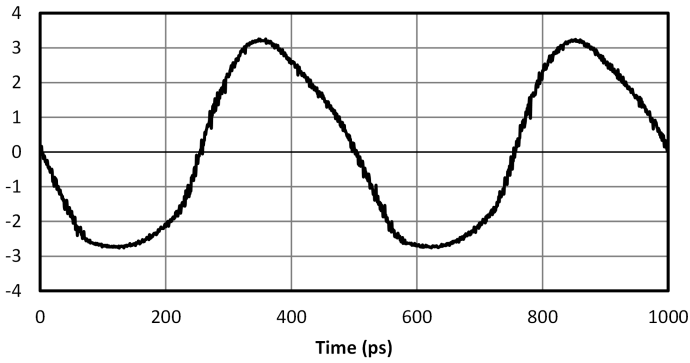

Output Waveform (V) vs. Time,
F = 2 GHz, +5V/+5V Bias, +15 dBm Input Power

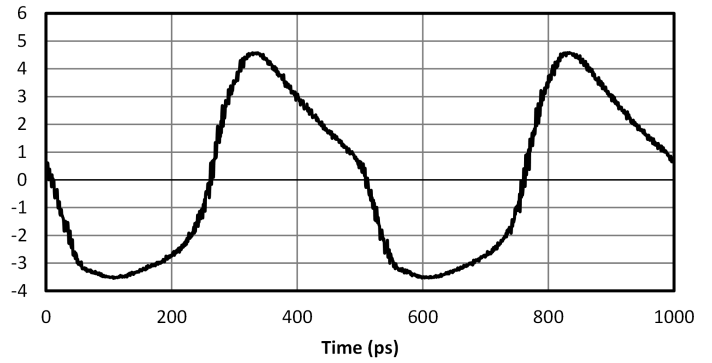

Output Waveform (V) vs. Time,
F = 5 GHz, +5V/+5V Bias, +15 dBm Input Power

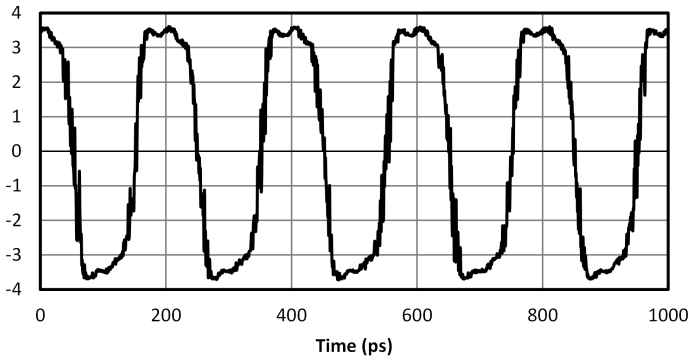

Output Waveform (V) vs. Time,
F = 10 GHz, +5V/+5V Bias, +15 dBm Input Power

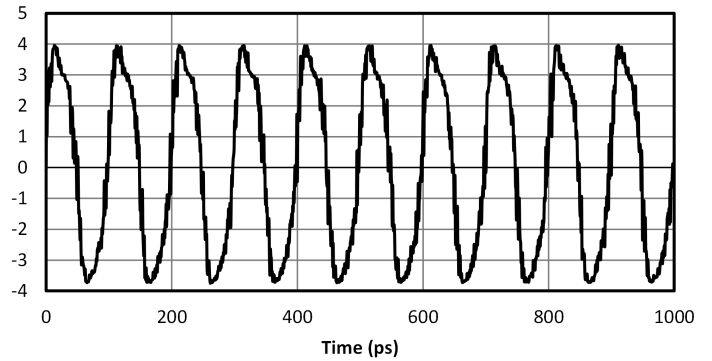

Mechanical Data

Outline Drawing

Download : [Outline 2D Drawing](#)

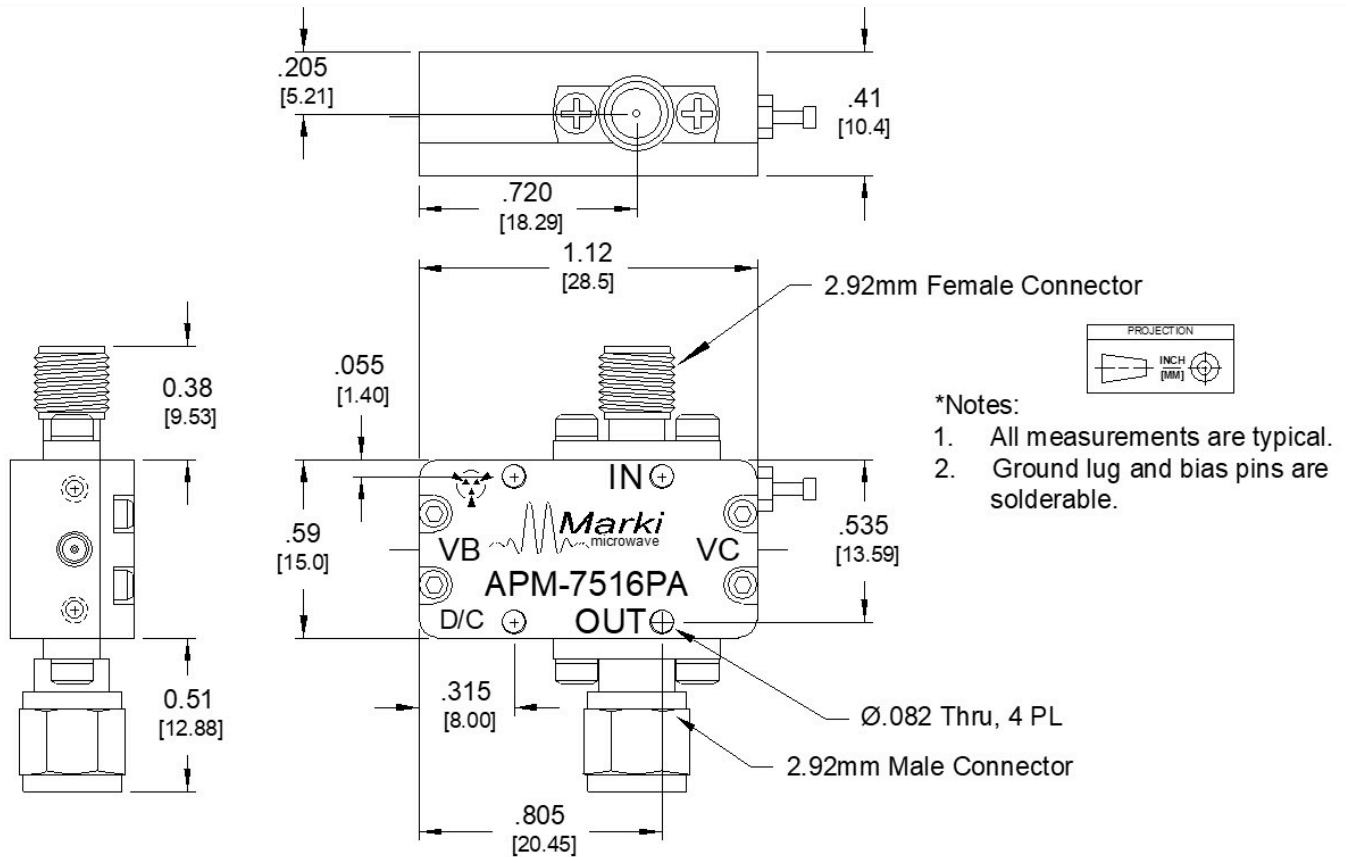

DISCLAIMER

MARKI MICROWAVE, LLC., (“MARKI”) PROVIDES TECHNICAL SPECIFICATIONS AND DATA (INCLUDING DATASHEETS), APPLICATION OR OTHER DESIGN ADVICE, WEB TOOLS, AND OTHER INFORMATION AND RESOURCES “AS IS” AND WITH ALL FAULTS. MARKI DISCLAIMS ALL WARRANTIES, EXPRESS OR IMPLIED, INCLUDING, WITHOUT LIMITATION, ANY IMPLIED WARRANTIES OF MERCHANTABILITY, FITNESS FOR A PARTICULAR PURPOSE, OR NON-INFRINGEMENT.

These resources are intended for developers skilled in the art designing with Marki products. You are solely responsible for (1) selecting the appropriate products for your application, (2) designing, validating, and testing your application, and (3) ensuring your application meets applicable standards and other requirements. Marki makes no guarantee regarding the suitability of its products for any particular purpose, nor does Marki assume any liability whatsoever arising out of your use or application of any Marki product.

Marki grants you permission to use these resources only for development of an application that uses Marki products. Other reproduction or use of these resources is strictly prohibited. No license is granted to any other Marki intellectual property or to any third-party intellectual property. Marki reserves the right to make changes to the product(s) or information contained herein without notice.

MARKI MICROWAVE and T3 MIXER are trademarks or registered trademarks of Marki Microwave, LLC. All other trademarks used are the property of their respective owners.

© 2022 - 2023, 2026, Marki Microwave, LLC