

MM1-1453LSM-2

GaAs MMIC Double Balanced Mixer

DEVICE OVERVIEW

General Description

The MM1-1453LSM is a GaAs MMIC double balanced mixer that features excellent conversion loss, superior isolations and spurious performance across a broad bandwidth. MM1-1453LSM works well as both an up and down converter and is recommend for low power applications that demand high linearity. If a higher LO drive is required, the MM1-1453HSM offers similar specifications in the same surface mount package. The MM1-1453LSM is available in a 4x4 mm QFN package. Evaluation boards are also available. The AMM-6702SM is recommended as the ideal LO driver for the MM1-1453LSM.

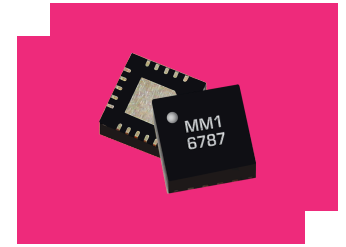

Features

RF/LO response: 14GHz - 53GHz
 IF response: DC – 22 GHz
 Conversion Loss: 8 dB
 LO to RF Isolation: 56 dB

Applications

- Test and Measurement Equipment
- SATCOM
- Radar
- mmWave Tuner Mixer

Functional Block Diagram

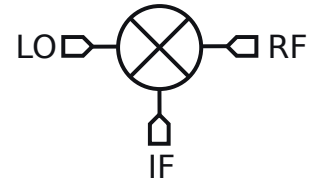

Part Ordering Options

Part Number	Description	Package	Green Status	Product Lifecycle	Export Classification
MM1-1453LSM-2	GaAs MMIC Double Balanced Mixer	QFN	REACH RoHS	Released	EAR99
EVAL-MM1-1453L	Evaluation Board, GaAs MMIC 14- 53 GHz Double Balanced Mixer	EVAL	REACH RoHS	Released	EAR99

Table Of Contents

- **Device Overview**
 - General Description
 - Features
 - Applications
 - Functional Block Diagram
- **Port Configuration and Functions**
 - Port Diagram
 - Port Functions
- **Revision History**
- **Specifications**
 - Absolute Maximum Ratings
 - Package Information
 - Recommended Operating Conditions
 - Sequencing Requirements
 - Electrical Specifications
 - Typical Performance Plots
 - Typical Performance Plots: IP3
 - Typical Performance Plots: LO Harmonic Isolation
 - Typical Spurious Performance: Tuner Mixer
 - Spur Tables
- **Operation**
 - Application Circuit Description
- **Mechanical Data**
 - Outline Drawing
- **Footprint Image**
- **Evaluation Board**
 - Evaluation Board Outline Drawing

Revision History

Revision Code	Revision Date	Comment
-	2020-08-01	Datasheet Initial Release

Port Configuration and Functions

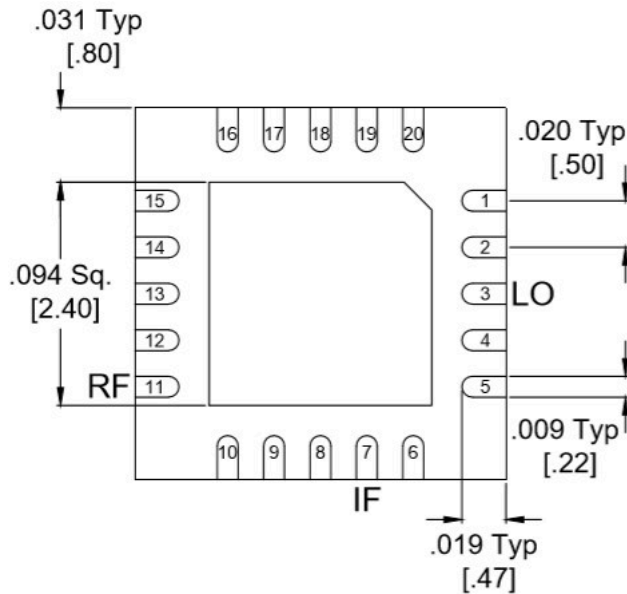

Port Diagram

A bottom-up view of the MM1-1453LSM's SM package outline drawing is shown below. The MM1-1453LSM has the input and output ports given in Port Functions. The MM1-1453LSM can be used in either an up or down conversion. For configuration A, input the LO into pin 3, use pin 11 for the RF, and pin 7 for the IF. For configuration B, input the LO into pin 11, use pin 3 for the RF, and pin 7 for the IF.

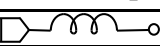

Port Functions

Configuration A

Port	Function	Description	Equivalent Circuit for Package
GND	Ground	SM package ground path is provided through the ground paddle.	
Pin 11	RF	Pin 11 is DC open and AC matched to 50 Ohms from 14 to 53 GHz.	
Pin 3	LO	Pin 3 is DC open and AC matched to 50 Ohms from 14 to 53 GHz.	
Pin 7	IF	Pin 7 is DC coupled to the diodes. Blocking capacitor is optional.	

Configuration B

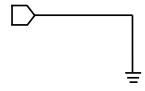
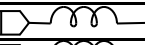
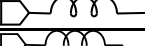
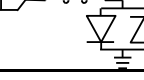
Port	Function	Description	Equivalent Circuit for Package
GND	Ground	SM package ground path is provided through the ground paddle.	
Pin 11	LO	Pin 11 is DC open and AC matched to 50 Ohms from 14 to 53 GHz.	
Pin 3	RF	Pin 3 is DC open and AC matched to 50 Ohms from 14 to 53 GHz.	
Pin 7	IF	Pin 7 is DC coupled to the diodes. Blocking capacitor is optional.	

Specifications

Absolute Maximum Ratings

The Absolute Maximum Ratings indicate limits beyond which damage may occur to the device. If these limits are exceeded, the device may be inoperable or have a reduced lifetime.

Parameter	Maximum Rating	Unit
Maximum Operating Temperature	100	°C
Maximum Storage Temperature	125	°C
Minimum Operating Temperature	-55	°C
Minimum Storage Temperature	-65	°C
Pin 7 DC Current	30	mA
Power Handling, at any Port	30	dBm

Package Information

Parameter	Details	Rating
ESD	250 to < 500 Volts	HBM Class 1A
Weight	Package name: QFN	0.041g
Dimensions	-	4 x 4 mm
Moisture Sensitivity Level	-	MSL 1

Recommended Operating Conditions

The Recommended Operating Conditions indicate the limits, inside which the device should be operated, to guarantee the performance given in Electrical Specifications. Operating outside these limits may not necessarily cause damage to the device, but the performance may degrade outside the limits of the electrical specifications. For limits, above which damage may occur, see Absolute Maximum Ratings.

Parameter	Min	Nominal	Max	Unit
Ambient Temperature	-55	25	100	°C
LO Input Power	7	-	15	dBm

Sequencing Requirements

There is no requirement to apply power to the ports in a specific order. However, it is recommended to provide a 50Ω termination to each port before applying power. This is a passive diode mixer that requires no DC bias.

Electrical Specifications

The electrical specifications apply at TA=+25°C in a 50Ω system. Typical data shown is for a down conversion application with a +13dBm sine wave LO input.

Parameter	Port Configuration	Test Conditions	Min	Typ	Max	Unit
Conversion Loss ¹	A	RF/LO = 14 - 50 GHz IF = 91 MHz	-	8	12	dB
Conversion Loss ²	A	RF/LO = 50 - 53 GHz IF = 91 MHz	-	13	14	dB
Input 1 dB Gain Compression Point (P1dB)	A	-	-	2	-	dBm
Input IP3	A	RF/LO = 14 - 53 GHz IF = 91 MHz	-	13	-	dBm
Isolation, LO to IF	A	IF/LO = 14 - 53 GHz	-	35	-	dB
Isolation, LO to RF	A	RF/LO = 14 - 53 GHz	-	56	-	dB
Isolation, RF to IF	A	RF/IF = 14 - 53 GHz	-	49	-	dB
Conversion Loss ³	B	RF/LO = 14 - 50 GHz IF = 91 MHz	-	9	11	dB
Conversion Loss ⁴	B	RF/LO = 50 - 53 GHz IF = 91 MHz	-	12	13	dB
Input 1 dB Gain Compression Point (P1dB)	B	-	-	3	-	dBm
Input IP3	B	RF/LO = 14 - 53 GHz IF = 91 MHz	-	16	-	dBm
Isolation, LO to IF	B	IF/LO = 14 - 53 GHz	-	51	-	dB
Isolation, LO to RF	B	RF/LO = 14 - 53 GHz	-	54	-	dB
Isolation, RF to IF	B	RF/IF = 14 - 53 GHz	-	38	-	dB
IF Frequency Range	-	-	0	-	22	GHz
LO Frequency Range	-	-	14	-	53	GHz
Noise Figure ⁵	-	RF/LO = 14 - 53 GHz IF = 91 MHz	-	8	-	dB
RF Frequency Range	-	-	14	-	53	GHz

[1][2][3][4] Measured as a down converter to a fixed 91MHz IF.

[5] Mixer Noise Figure typically measures within 0.5 dB of conversion loss for IF frequencies greater than 5 MHz.

Typical Performance Plots

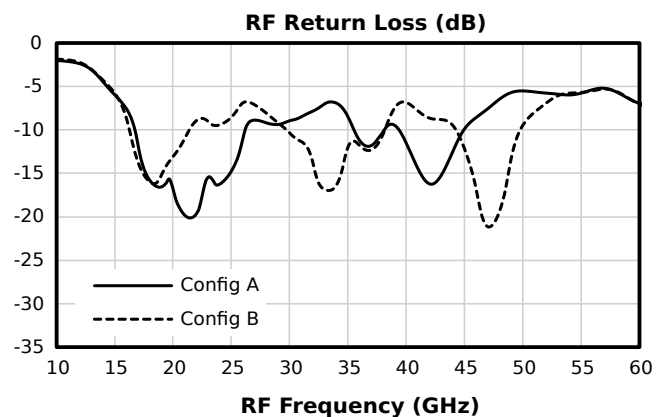
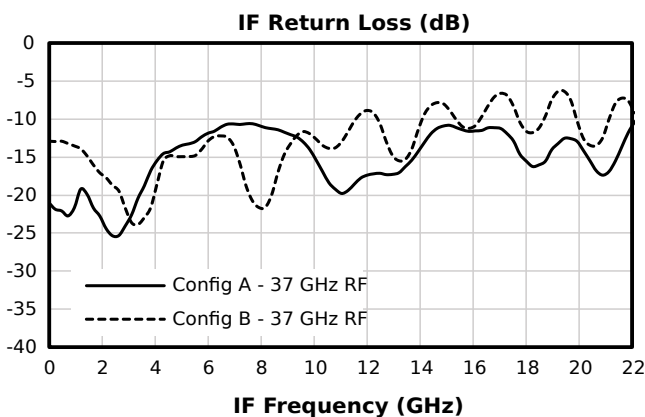
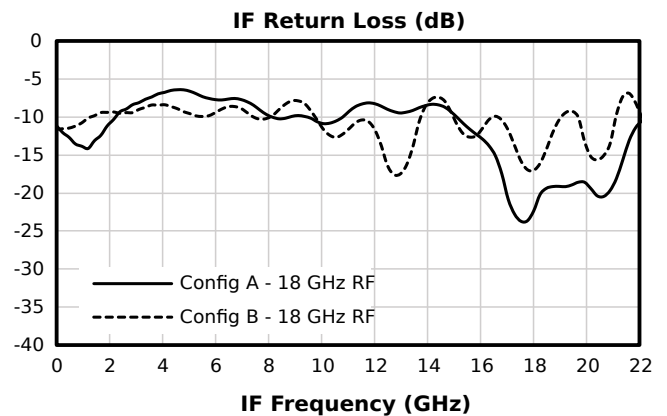
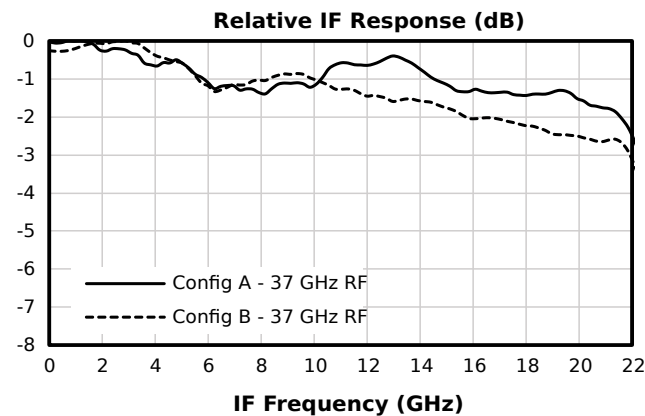
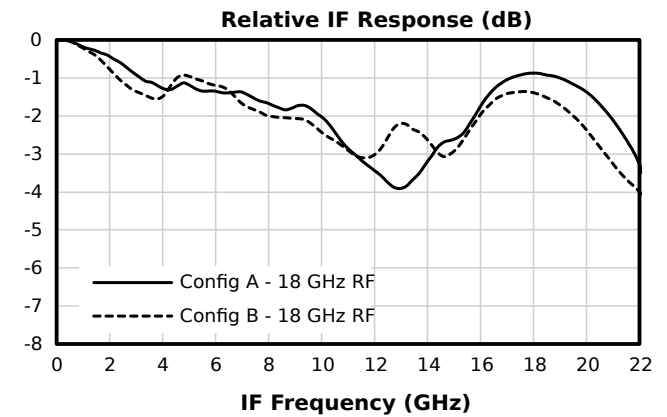
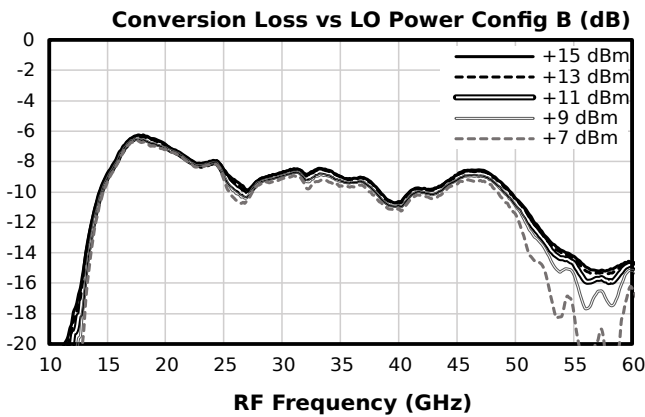
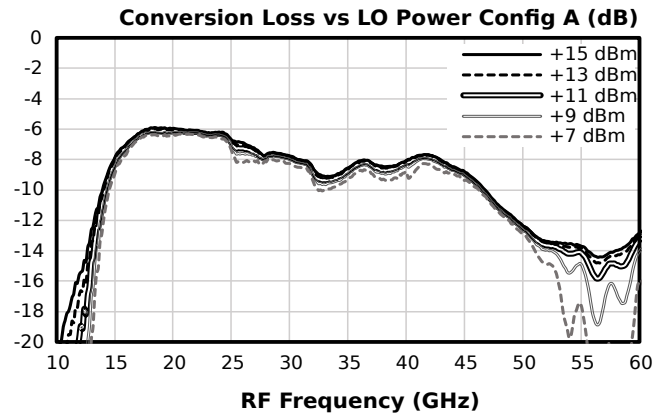
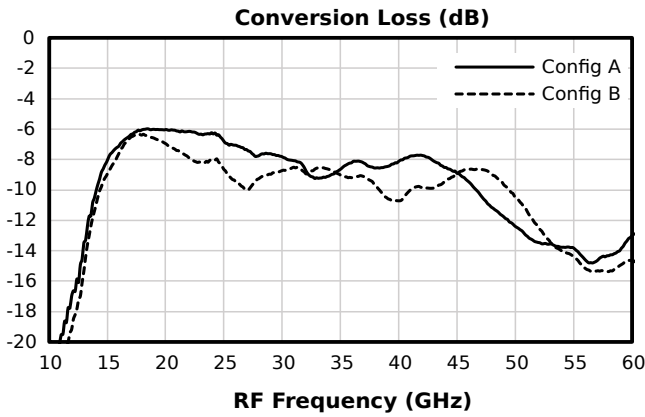

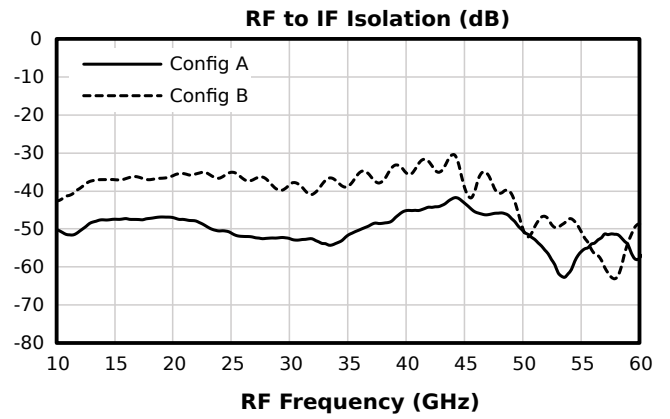
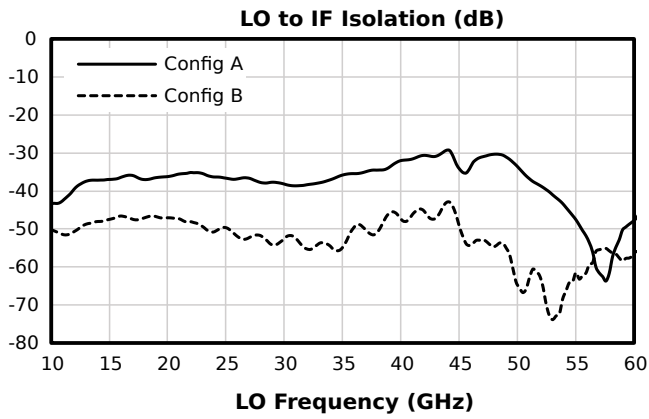
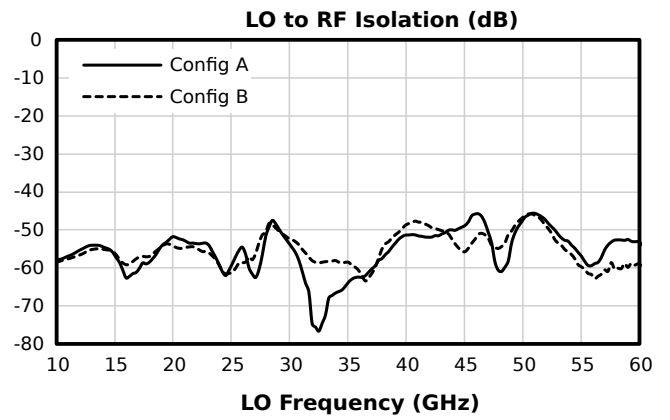
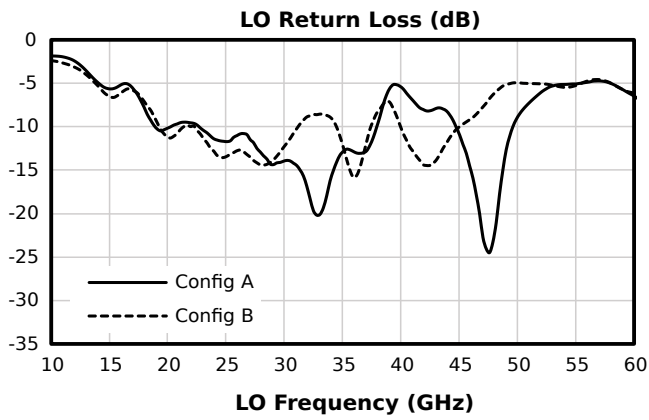

Typical Performance Plots: IP3

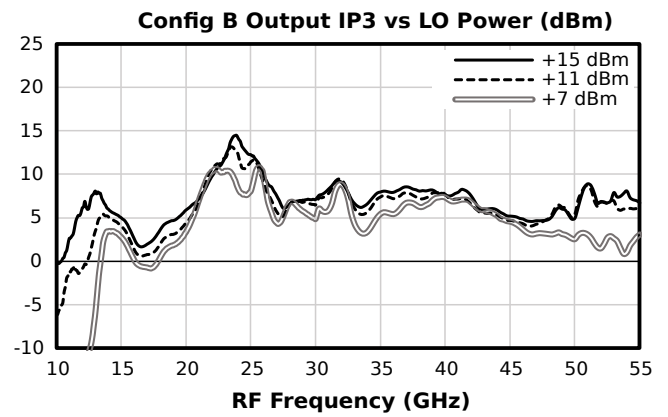
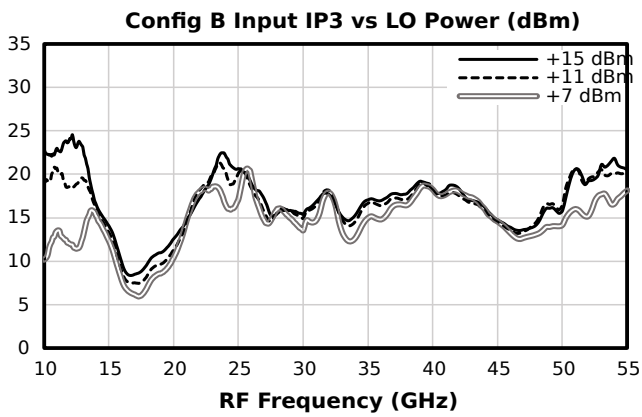
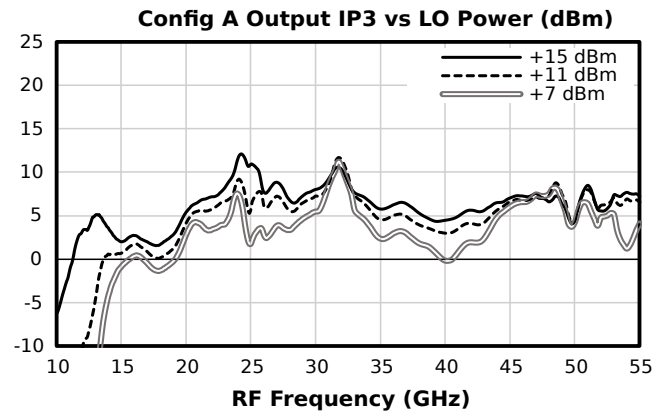
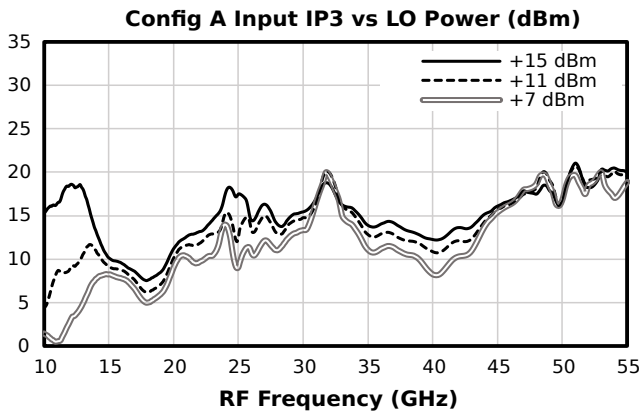
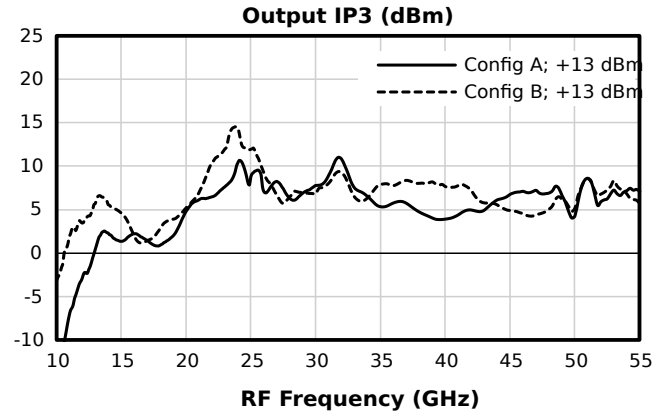
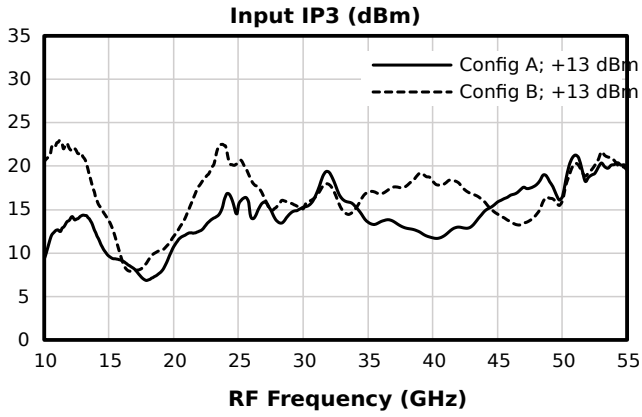

Typical Performance Plots: LO Harmonic Isolation

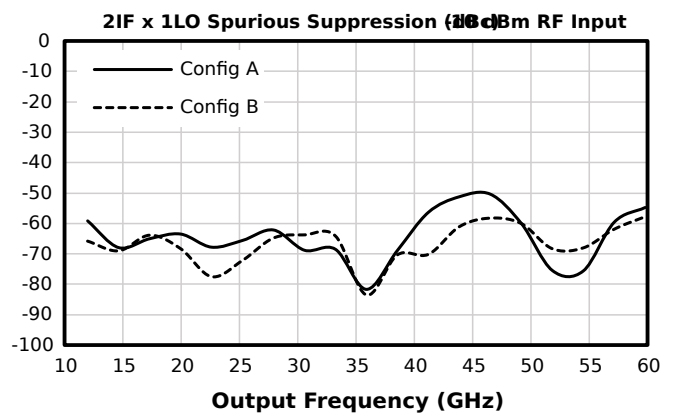
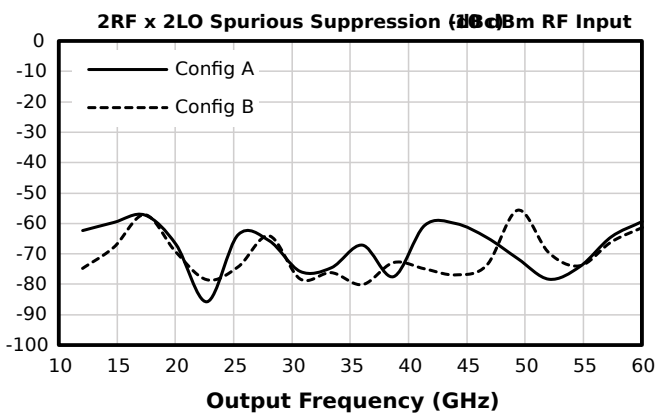
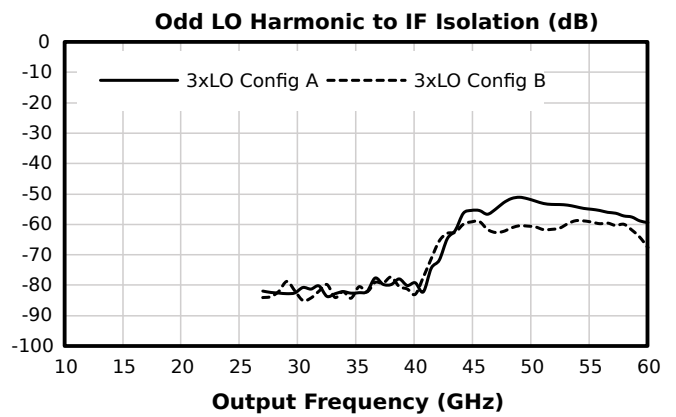
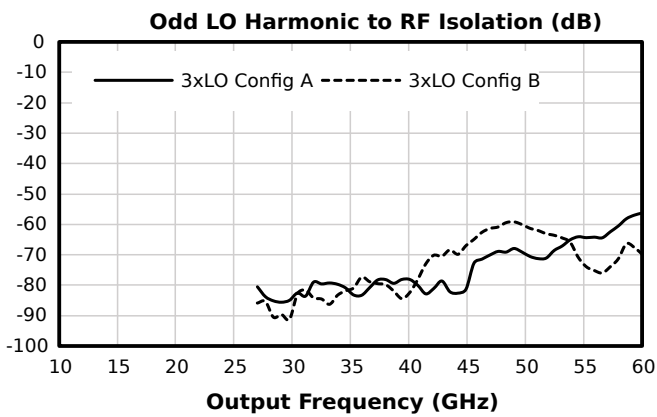
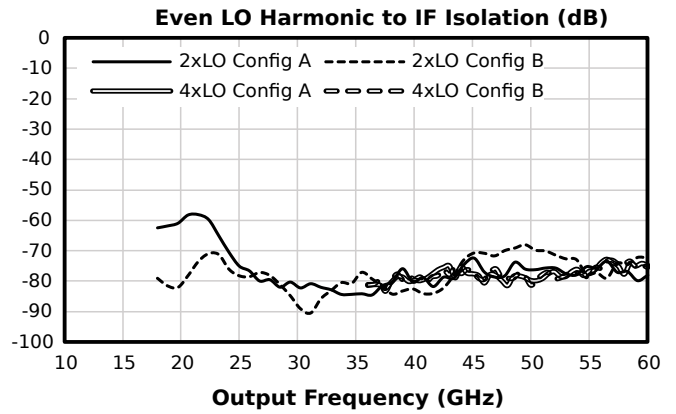
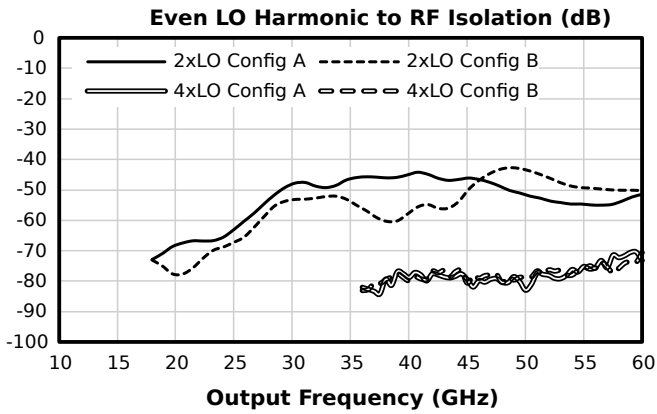

Typical Spurious Performance: Tuner Mixer

Tuner mixer performance plots are taken with the following test conditions and frequency plan:

Parameter	Start	Nominal	Stop	Units
IF Input Frequency	0		24	GHz
IF Input Power		-10		dBm
LO Input Frequency	24		48	GHz
LO Input Power		+13		dBm
RF Output Frequency		24		GHz

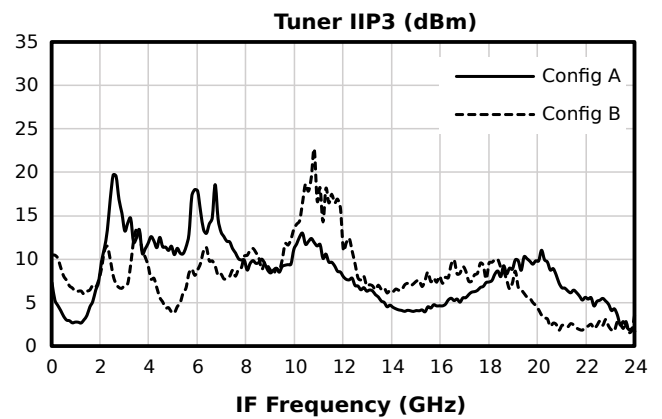
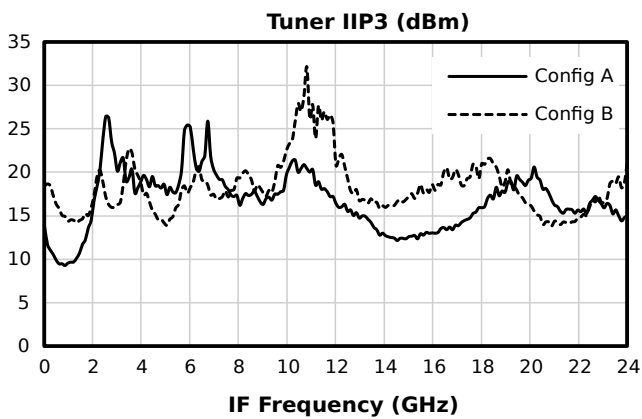
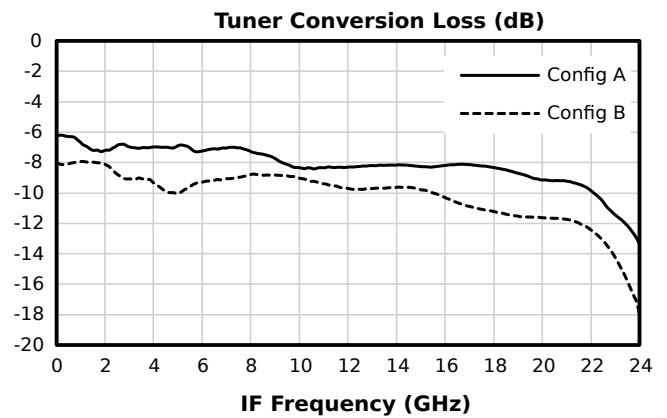
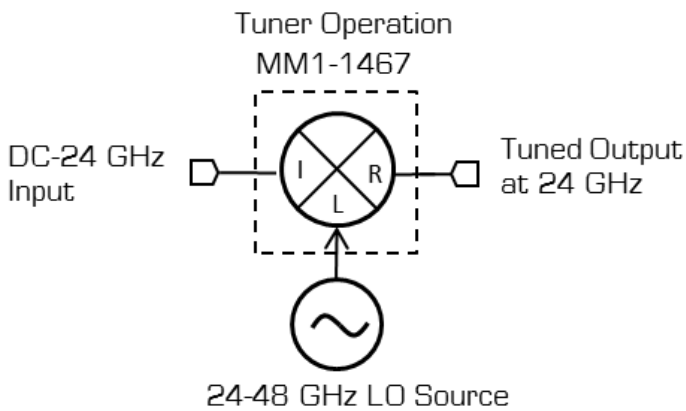

Spur Table

Typical Spurious Performance: Down-Conversion

Typical spurious data is provided by selecting RF and LO frequencies ($\pm m \cdot LO \pm n \cdot RF$) within the RF/LO bands, to create a spurious output within the IF band. The mixer is swept across the full spurious band and the mean is calculated. The numbers shown in the table below are for a -10 dBm RF input. Spurious suppression is scaled for different RF power levels by $(n-1)$, where “n” is the RF spur order. For example, the $2RF \times 2LO$ spur is 68 dBc for a -10 dBm input, so a -20 dBm RF input creates a spur that is $(2-1) \times (-10 \text{ dB})$ lower, or 78 dBc. Data is shown for the frequency plan in 3.6 Typical Performance. $mLO \times 0RF$ plots can be found in section 3.6.2 Typical Performance Plots: LO Harmonic Isolation. $0LO \times 1RF$ plot is identical to the plot of LO-RF isolation.

Typical Down-conversion spurious suppression (dBc): Config A (B)

-10 dBm RF Input	0xLO	1xLO	2xLO	3xLO	4xLO	5xLO
1xRF	39 (27)	Reference	44 (35)	16 (14)	46 (32)	N/A
2xRF	89 (90)	52 (63)	68 (71)	57 (61)	70 (72)	62 (67)
3xRF	90 (86)	54 (57)	85 (80)	62 (64)	85 (79)	61 (62)
4xRF	124 (124)	92 (112)	93 (104)	95 (102)	106 (110)	100 (104)
5xRF	N/A	110 (130)	110 (102)	101 (107)	121 (116)	105 (110)

Typical Spurious Performance: Up-Conversion

Typical spurious data is taken by mixing an input within the IF band, with LO frequencies ($\pm m \cdot LO \pm n \cdot IF$), to create a spurious output within the RF output band. The mixer is swept across the full spurious output band and the mean is calculated. The numbers shown in the table below are for a -10 dBm IF input. Spurious suppression is scaled for different IF input power levels by (n-1), where “n” is the IF spur order. For example, the 2IFx1LO spur is typically 64 dBc for a -10 dBm input with a sine-wave LO, so a -20 dBm IF input creates a spur that is (2-1) x (-10 dB) lower, or 74 dBc. Data is shown for the frequency plan in 3.6 Typical Performance.

Typical Up-conversion spurious suppression (dBc): Config A (B)

-10 dBm IF Input	0xLO	1xLO	2xLO	3xLO	4xLO	5xLO
1xIF	39 (27)	Reference	44 (36)	15 (13)	51 (34)	N/A
2xIF	63 (64)	64 (67)	56 (57)	73 (68)	63 (63)	82 (78)
3xIF	82 (79)	53 (57)	81 (73)	49 (47)	81 (66)	59 (62)
4xIF	98 (96)	102 (104)	94 (95)	100 (99)	94 (92)	103 (99)
5xIF	98 (98)	91 (97)	128 (121)	78 (79)	105 (99)	102 (79)

Application Circuit Description

Ports Operation

IF Port – Used as input on an upconversion, output on downconversion, or LO port in a band shifting application. Signals should be connected by 50 ohm microstrip or coplanar traces to well matched broadband 50 ohm sources and loads. Blocking capacitor is recommended if DC voltage is present on the line.

RF Port – Used as input on a downconversion, output on upconversion, or output in a band shifting application. Signals should be connected by 50 ohm microstrip or coplanar traces to well matched broadband 50 ohm sources and loads.

Filtering and Matching- Filtering is generally desired for spurious and image removal on the output port of the mixer. Reflective filters can cause out of band signals to reflect back into the mixer and cause conversion loss ripple, erroneous spurs, and other undesired behaviors. To eliminate these problems it is recommend that the filters be placed as close to the output port as possible. If undesired behavior is still observed, a diplexer with one port terminated or a 1-3 dB attenuator may reduce this problem.

RF Ground – The ground paddle of the QFN should be connected to a low noise RF ground with very low electrical resistance for high frequency operation.

LO Port – The noise floor of the LO input signal should be less than the value of the noise floor plus isolation of the mixer, or a filter is recommended to prevent reduction in dynamic range. An LO amplifier is required if the LO power is below the recommended drive level. It is important to use an amplifier with a broadband 50 ohm match such that it does not reflect spurious signals back into the mixer or other system circuitry.

Mechanical Data

Outline Drawing

Download : [Outline 2D Drawing](#) | [Outline 3D Drawing](#) | [Outline 3D STP](#)

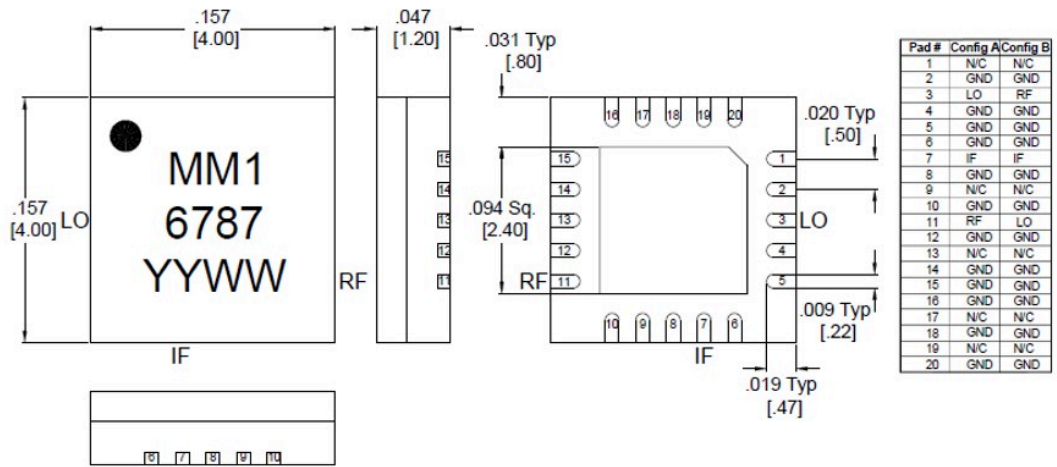

- Substrate material is LCP.
- I/O Leads and Ground Paddle plating is (from base to finish):
 - Ni: 0.5um MIN
 - Pd: 0.08um MIN
 - Au 0.05um MAX
- All unconnected pads should be connected to PCB RF ground.

Footprint Image

Download : [Footprint Drawing](#)

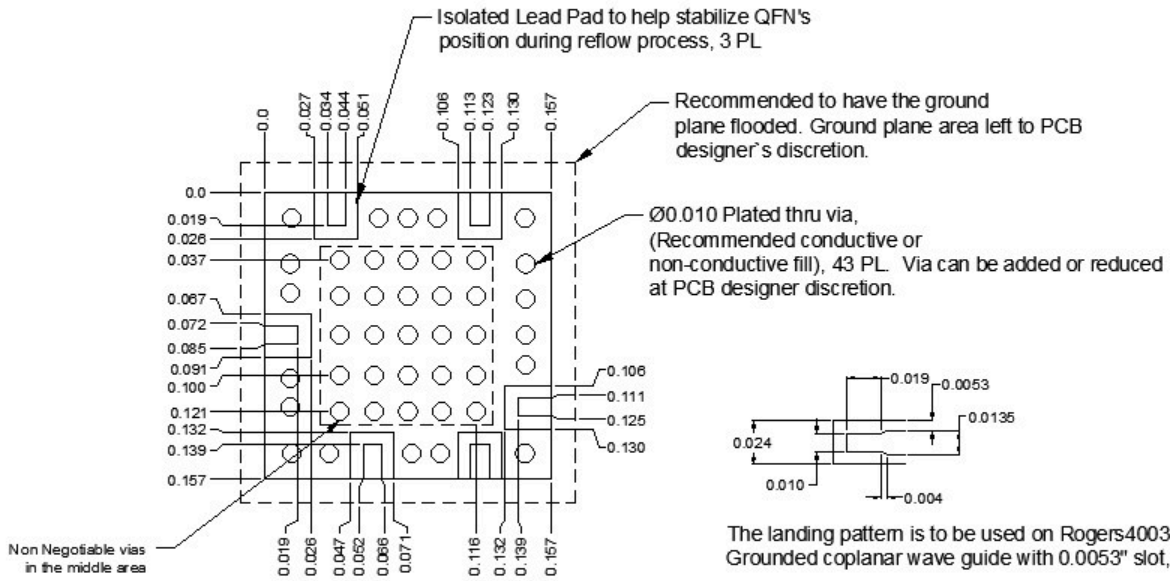

Evaluation Board - Outline Drawing

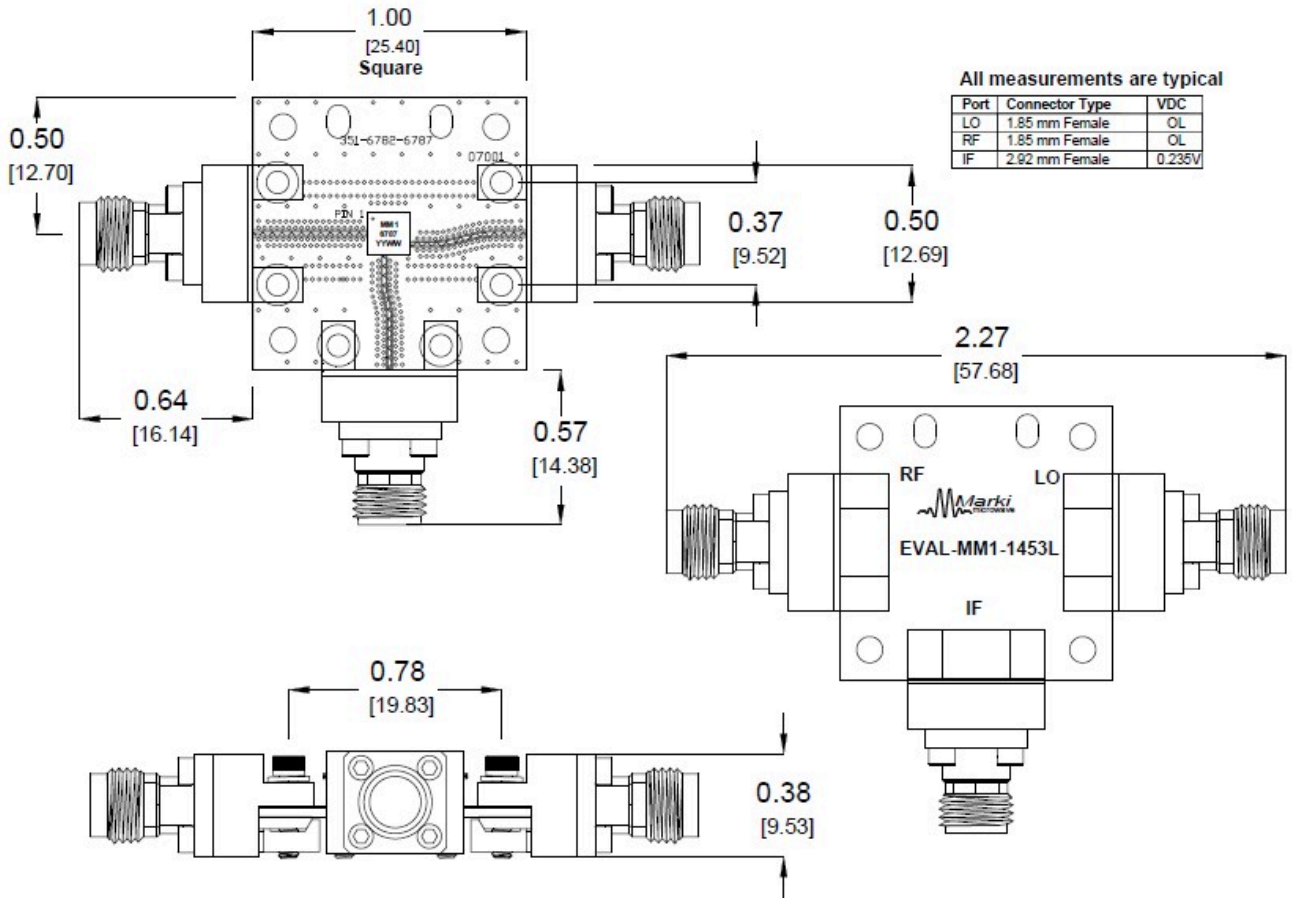

DISCLAIMER

MARKI MICROWAVE, INC., ("MARKI") PROVIDES TECHNICAL SPECIFICATIONS AND DATA (INCLUDING DATASHEETS), APPLICATION OR OTHER DESIGN ADVICE, WEB TOOLS, AND OTHER INFORMATION AND RESOURCES "AS IS" AND WITH ALL FAULTS. MARKI DISCLAIMS ALL WARRANTIES, EXPRESS OR IMPLIED, INCLUDING, WITHOUT LIMITATION, ANY IMPLIED WARRANTIES OF MERCHANTABILITY, FITNESS FOR A PARTICULAR PURPOSE, OR NON-INFRINGEMENT.

These resources are intended for developers skilled in the art designing with Marki products. You are solely responsible for (1) selecting the appropriate products for your application, (2) designing, validating, and testing your application, and (3) ensuring your application meets applicable standards and other requirements. Marki makes no guarantee regarding the suitability of its products for any particular purpose, nor does Marki assume any liability whatsoever arising out of your use or application of any Marki product.

Marki grants you permission to use these resources only for development of an application that uses Marki products. Other reproduction or use of these resources is strictly prohibited. No license is granted to any other Marki intellectual property or to any third-party intellectual property. Marki reserves the right to make changes to the product(s) or information contained herein without notice.

MARKI MICROWAVE and T3 MIXER are trademarks or registered trademarks of Marki Microwave, Inc. All other trademarks used are the property of their respective owners.

© 2020, Marki Microwave, Inc