

MT3-0113SCQG-2

GaAs MMIC High Dynamic Range Mixer

DEVICE OVERVIEW

General Description

The MT3-0113SCQG is a triple balanced passive diode GaAs MMIC mixer offering high dynamic range, low conversion loss, and excellent repeatability. As with all T3 mixers, this mixer offers unparalleled nonlinear performance in terms of IIP3, P1dB, and spurious performance with a flexible LO drive requirement from +22 dBm to +30 dBm. The MT3-0113SCQG is available in a surface-mount outline, or in an SMA connectorized evaluation fixture. The MT3-0113SCQG is a superior alternative to Marki Microwave carrier and packaged T3 mixers, and is form-fit compatible with legacy T3's in the CQ and CQG footprints.

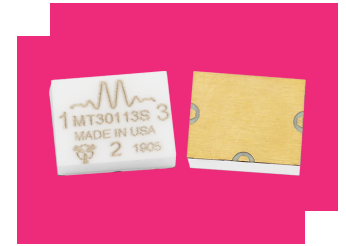

Features

- Form-Fit Compatible with Legacy CQ and CQG T3 Mixers
- Broadband, Overlapping RF, LO and IF
- Suitable for Up or Down Conversion
- Compatible with Sine or Square-Wave LO
- Industry-Leading Spurious, IP3, and P1dB Performance

Applications

N/A

Functional Block Diagram

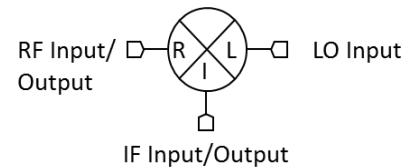

Part Ordering Options

Part Number	Description	Package	Green Status	Product Lifecycle	Export Classification
MT3-0113SCQG-2	GaAs MMIC High Dynamic Range Mixer	CQG	REACH RoHS	Released	EAR99
EVAL-MT3-0113S	Evaluation Board, GaAs MMIC High Dynamic Range Mixer	EVAL	REACH RoHS	Released	EAR99

Table Of Contents

- **Device Overview**
 - General Description
 - Features
 - Applications
 - Functional Block Diagram
- **Port Configuration and Functions**
 - Port Diagram
 - Port Functions
- **Revision History**
- **Specifications**
 - Absolute Maximum Ratings
 - Package Information
 - Recommended Operating Conditions
 - Electrical Specifications
 - Typical Performance Plots
 - Spur Tables
- **Operation**
 - Application Information
- **Mechanical Data**
 - Outline Drawing
- **Footprint Image**
- **Evaluation Board**
- **Notes**

Revision History

Revision Code	Revision Date	Comment
-	2019-08-01	Initial Release
A	2020-05-01	Changed cover to ceramic

Port Configuration and Functions

Port Diagram

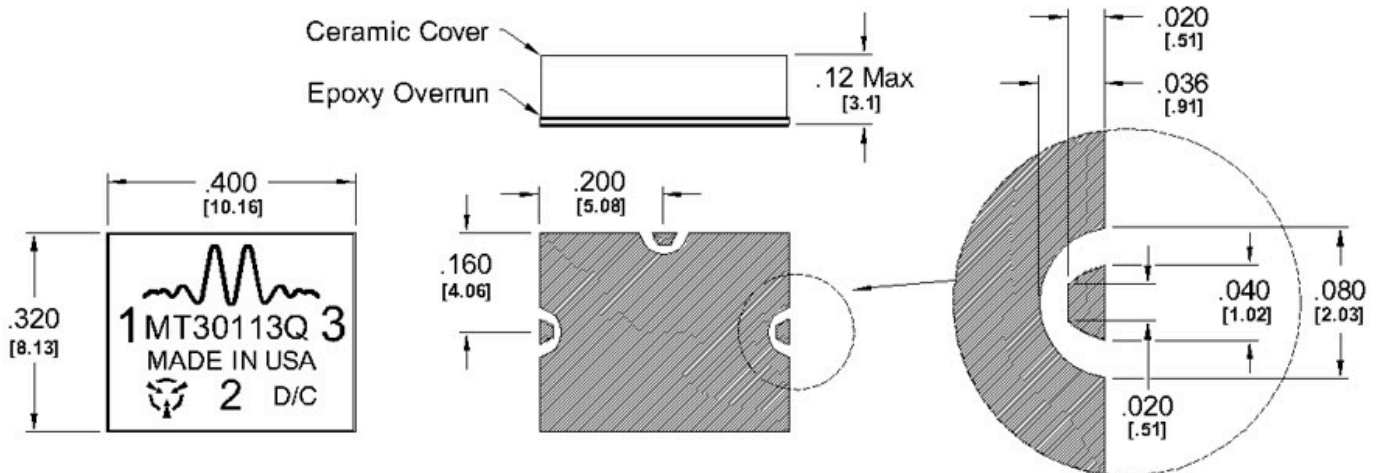

I/O Connections & Ground Plane Finish is Gold Flash, 5 to 10 μ -inches, over Solderable Nickel, 100-200 μ -inches, over Cu.

Port Functions

Configuration A

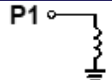
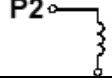
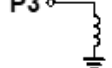
Port	Function	Description	Equivalent Circuit for Package
Port 1	LO Input	Port 1 is DC short and AC matched to 50 Ω from 1.5 to 13 GHz. Blocking capacitor is optional.	
Port 2	IF Input/Output	Port 2 is DC open. Blocking capacitor is optional.	
Port 3	RF Input / Output	Port 3 is DC short and AC matched to 50 Ω from 1.5 to 13 GHz. Blocking capacitor is optional.	

Configuration B

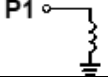
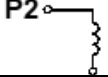
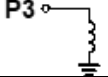
Port	Function	Description	Equivalent Circuit for Package
Port 1	RF Input / Output	Port 1 is DC short and AC matched to 50 Ω from 1.5 to 13 GHz. Blocking capacitor is optional.	
Port 2	IF Input/Output	Port 2 is DC open. Blocking capacitor is optional.	
Port 3	LO Input	Port 3 is DC short and AC matched to 50 Ω from 1.5 to 13 GHz. Blocking capacitor is optional.	

Specifications

Absolute Maximum Ratings

Parameter	Maximum Rating	Unit
Maximum Operating Temperature	100	°C
Maximum Storage Temperature	150	°C
Minimum Operating Temperature	-40	°C
Minimum Storage Temperature	-40	°C
RF Power Handling	33	dBm

Package Information

Parameter	Details	Rating
ESD	250 to < 500 Volts	HBM Class 1A
Dimensions	-	10.16 x 8.13 mm
Moisture Sensitivity Level	-	MSL 1

Recommended Operating Conditions

Parameter	Min	Nominal	Max	Unit
LO Input Power	22	-	30	-

Electrical Specifications

Specifications guaranteed over -40 to +100°C temperature range, measured in a 50Ω system.

Parameter	Port Configuration	Test Conditions	Min	Typ	Max	Unit
Conversion Loss ¹	A	LO/RF=1.5-13 GHz IF=0.01-0.5 GHz LO Drive Level=27 dBm	-	8.5	12	dB
Conversion Loss ²	A	LO/RF=1.5-13 GHz IF=0.5-7.0 GHz	-	11.5	-	dB
IF Frequency Range	A	-	0.01	-	7	GHz
Input IP3 ³	A	LO/RF=1.5-13 GHz IF=0.01-7 GHz LO drive level=22-30 dBm	-	36	-	dBm
LO Frequency Range	A	-	1.5	-	13	GHz
RF Frequency Range	A	-	1.5	-	13	GHz
Conversion Loss ⁴	B	LO/RF=1.5-13 GHz IF=0.01-0.5 GHz LO Drive Level=27 dBm	-	8.5	-	dB
Conversion Loss ⁵	B	LO/RF=1.5-13 GHz IF=0.5-7.0 GHz	-	11.5	-	dB
Input IP3 ⁶	B	LO/RF=1.5-13 GHz IF=0.01-7 GHz LO drive level=22-30 dBm	-	35	-	dBm
Isolation, LO to RF	-	-	-	40	-	dB

[1][2][4][5] Unless otherwise specified, Conversion Loss and Spurious data is measured with a 100 MHz fixed IF.

[3][6] The typical value is for a +27 dBm LO. IP3 is dependent on LO drive and waveform. See plots and data sheet notes for more details.

Typical Performance Plots

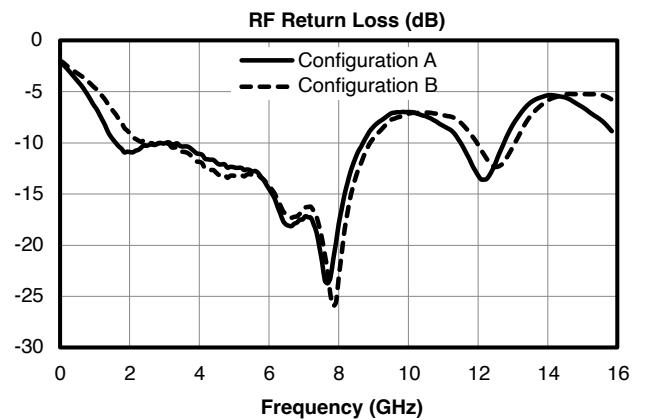
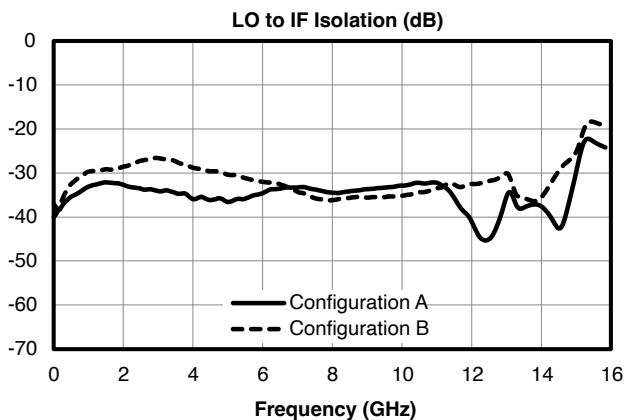
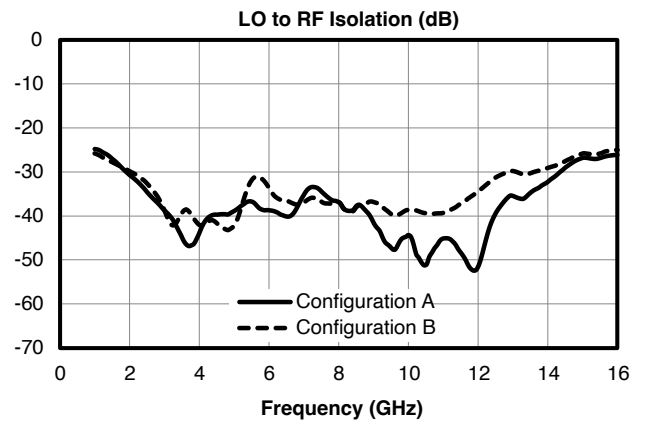
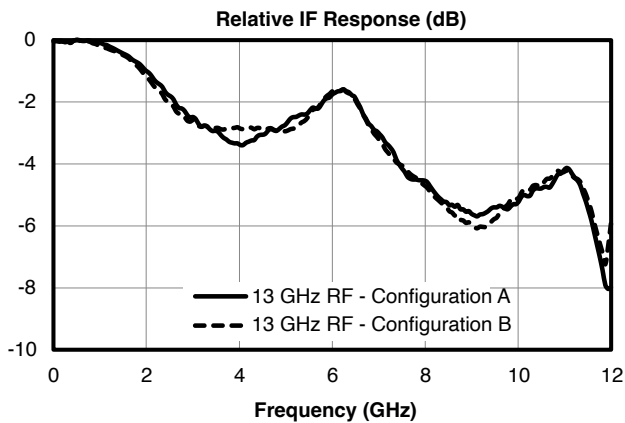
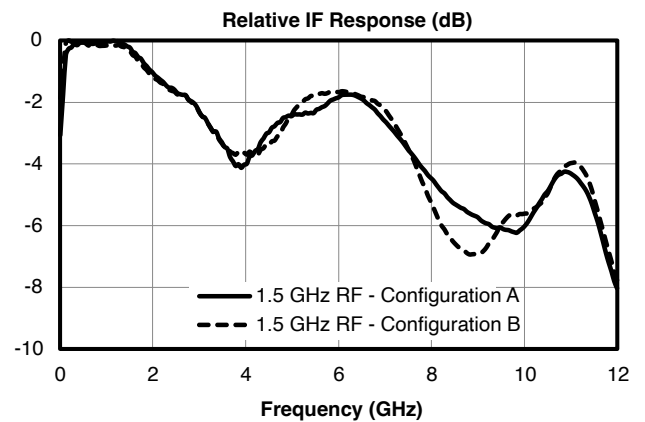
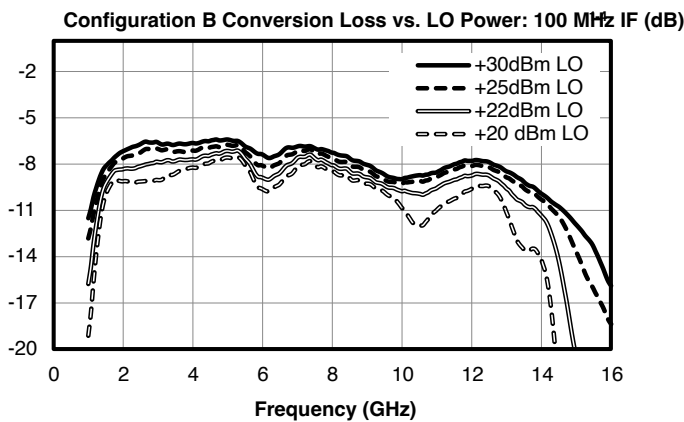
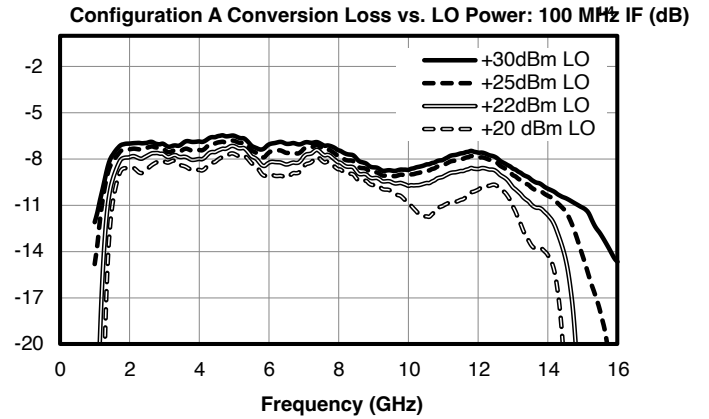
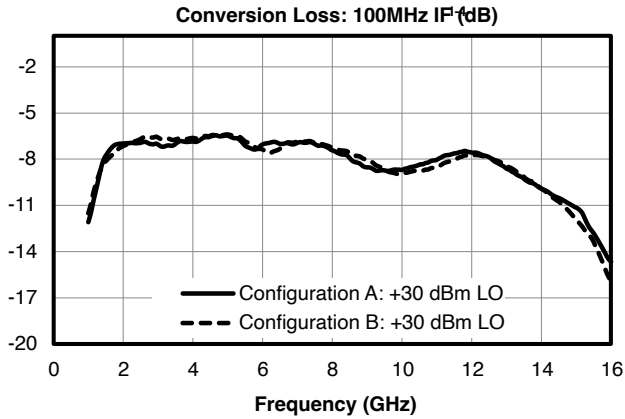

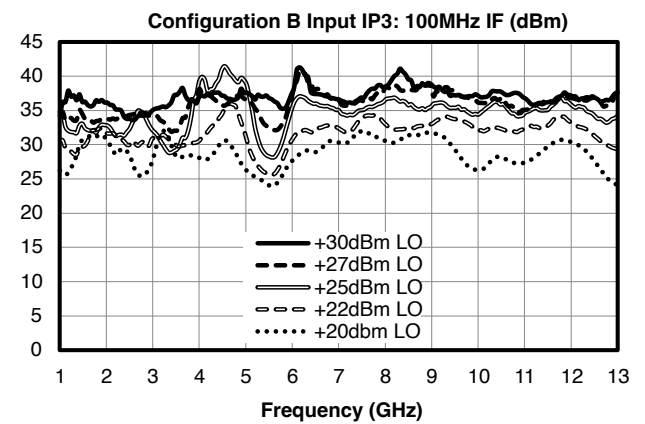
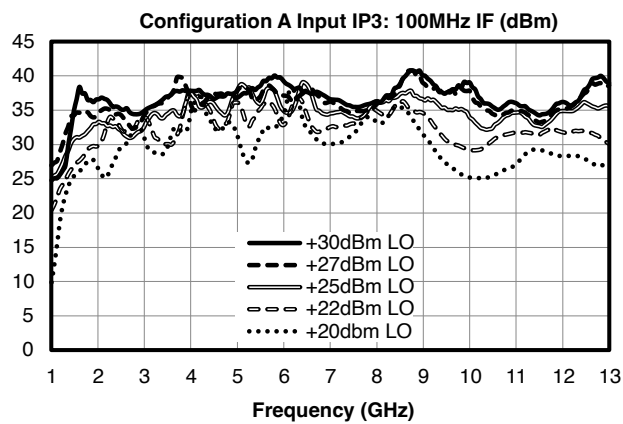
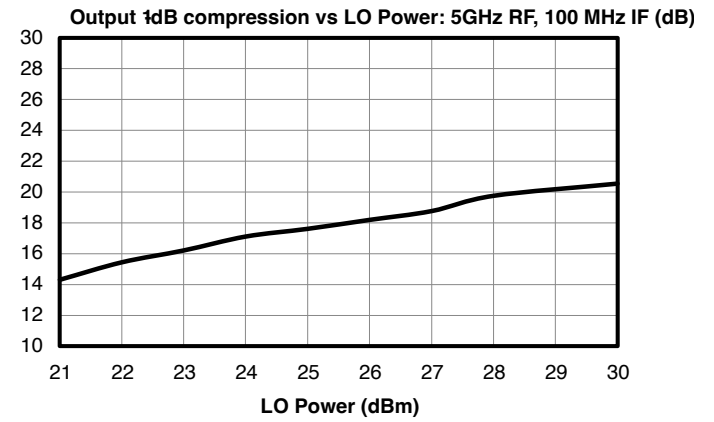
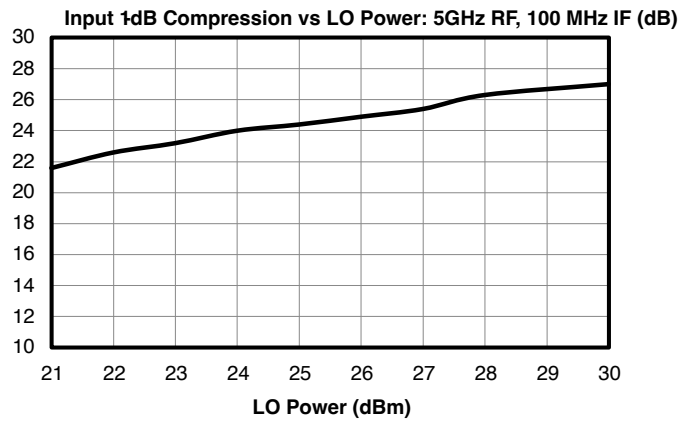
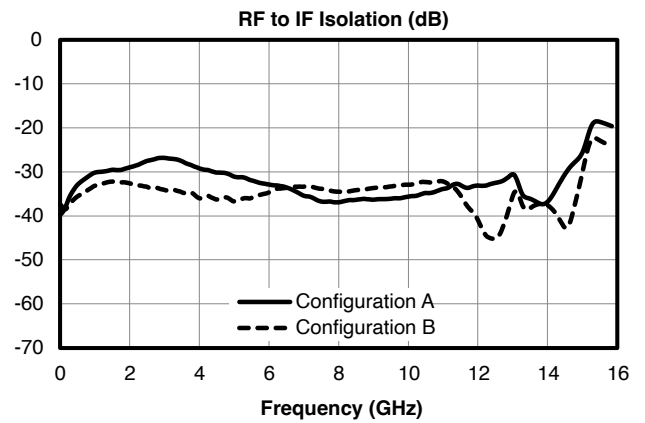
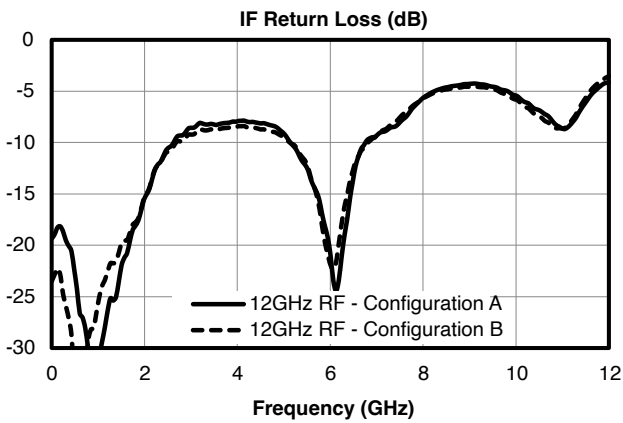
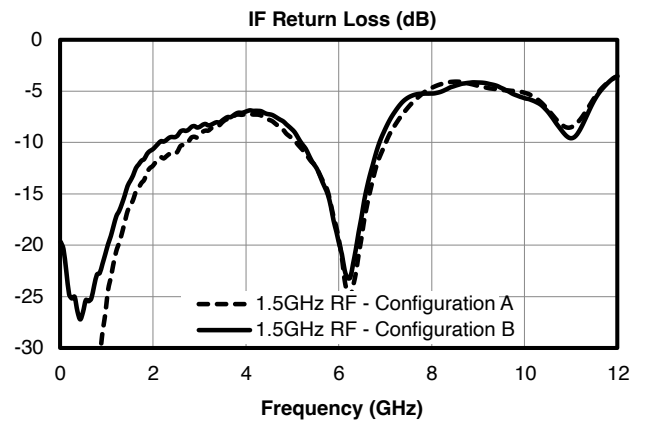
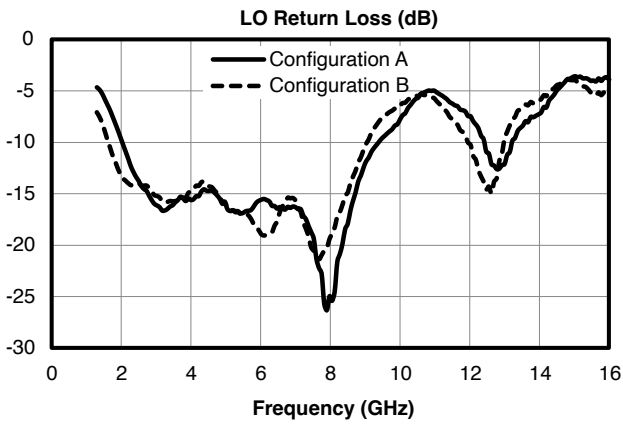

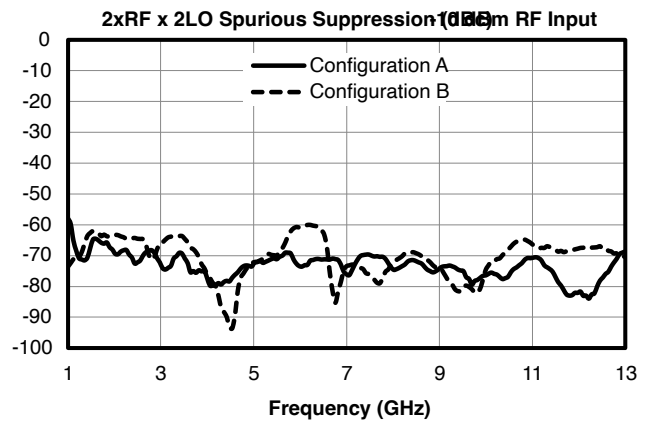
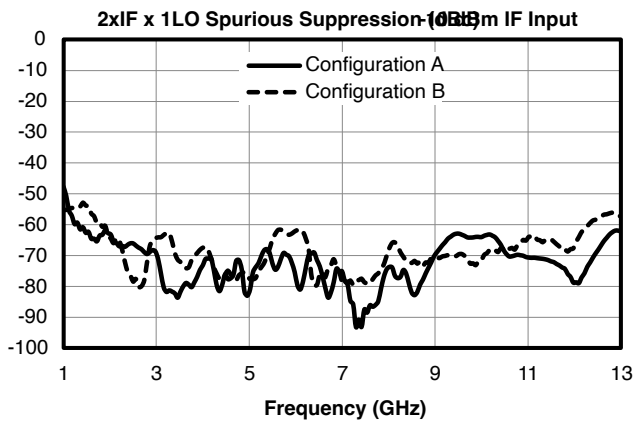
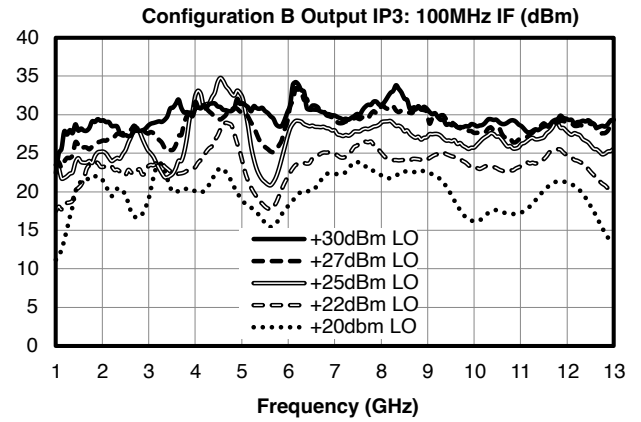
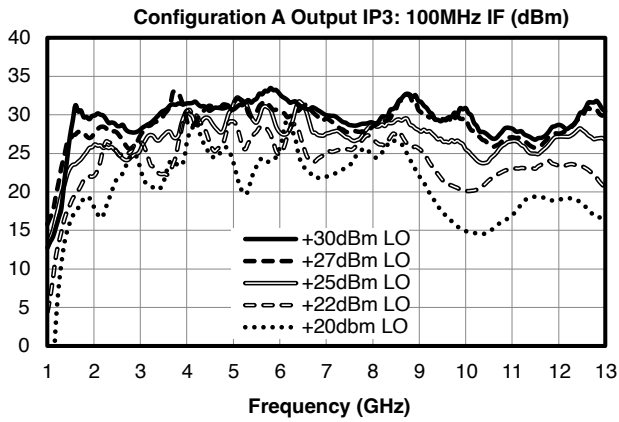

Spur Table

Example Downconversion Spurious Suppression

The numbers shown in the chart below are for a 0 dBm RF input. Spurious suppression is scaled for different RF power levels by (n-1), where “n” is the RF spur order. For example, the 2RFx2LO spur is 67 dBc for the A configuration for a 0 dBm input with a sine-wave LO, so a -10 dBm RF input creates a spur that is (2-1) x (-10 dB) dB lower, or 77 dBc.

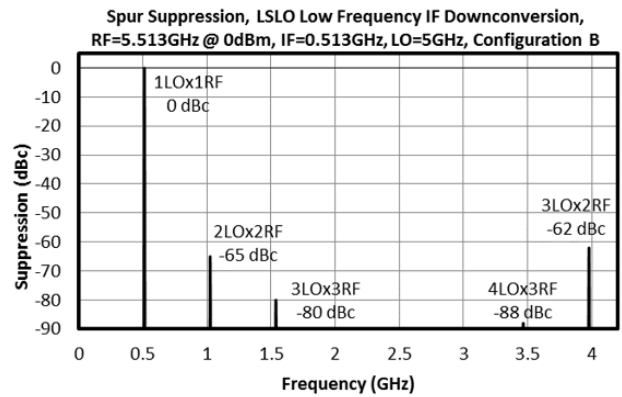
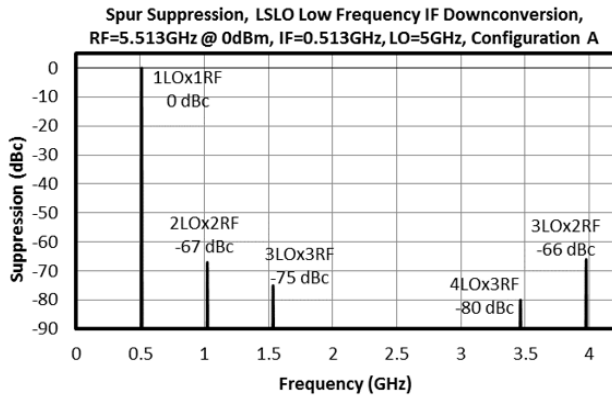

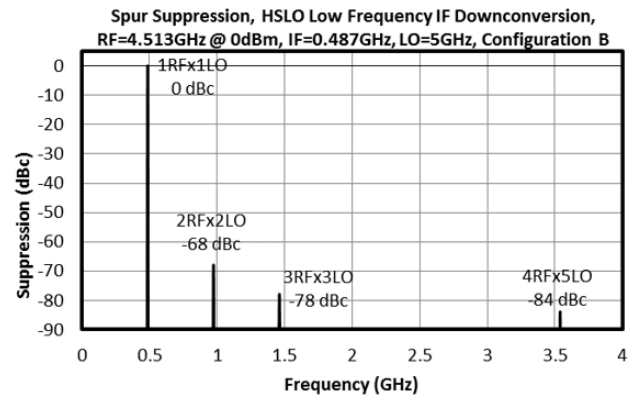
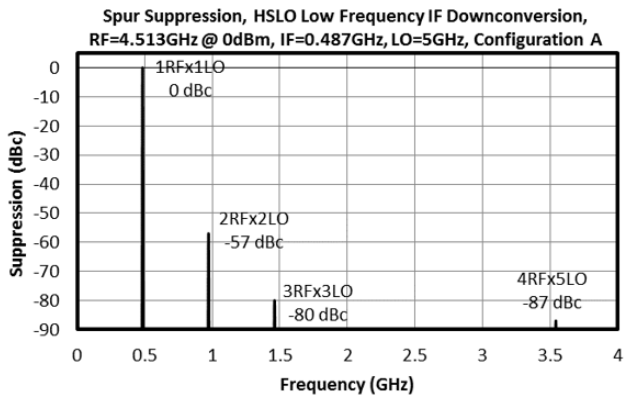

Example Upconversion Spurious Suppression

The numbers shown in the chart below are for a 0 dBm RF input. Spurious suppression is scaled for different RF power levels by (n-1), where “n” is the RF spur order. For example, the 1LOx2IF spur is 56 dBc for the A configuration for a 0 dBm input with a sine-wave LO, so a -10 dBm IF input creates a spur that is (2-1) x (-10 dB) dB lower, or 66 dBc.

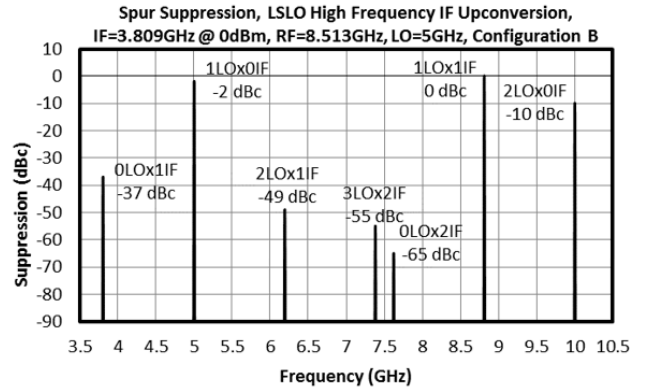
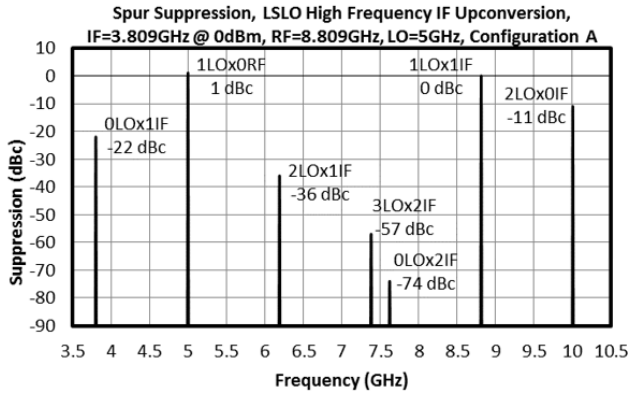

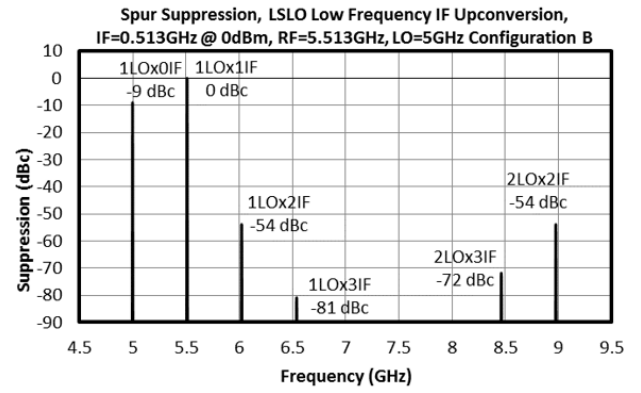
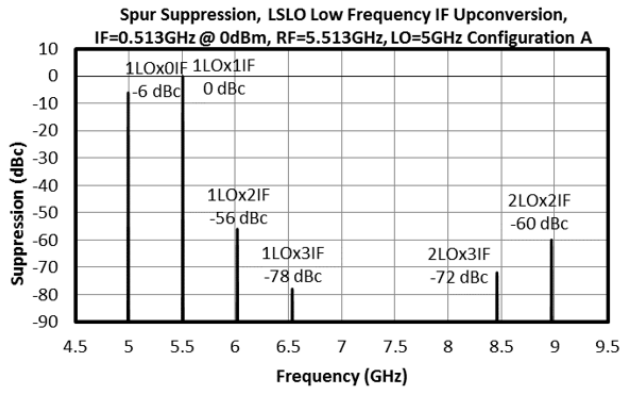

Application Information

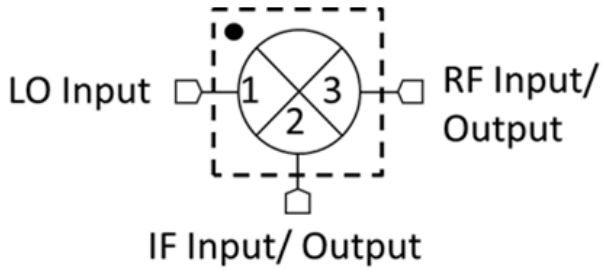

Configuration A

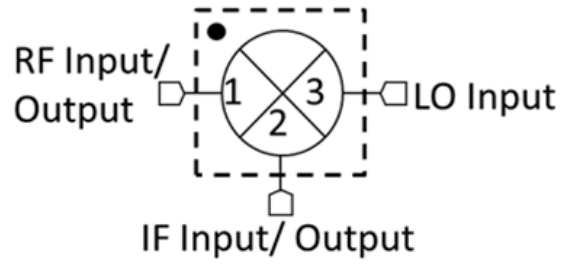

Configuration B

Configuration A/B refer to the same part number (MT3-0113SCQG) used in one of two different ways for optimal spurious performance. For the lowest conversion loss, use the mixer in Configuration A (port 1 as the LO input, port 3 as the RF input or output). If you need to use a lower LO drive, use the mixer in Configuration B (port 1 as the RF input or output, port 3 as the LO input). For optimal spurious suppression, experimentation or simulation is required to choose between Configuration A and B.

Mechanical Data

Outline Drawing

Download : [Outline 3D Drawing](#) | [Outline 3D STP](#)

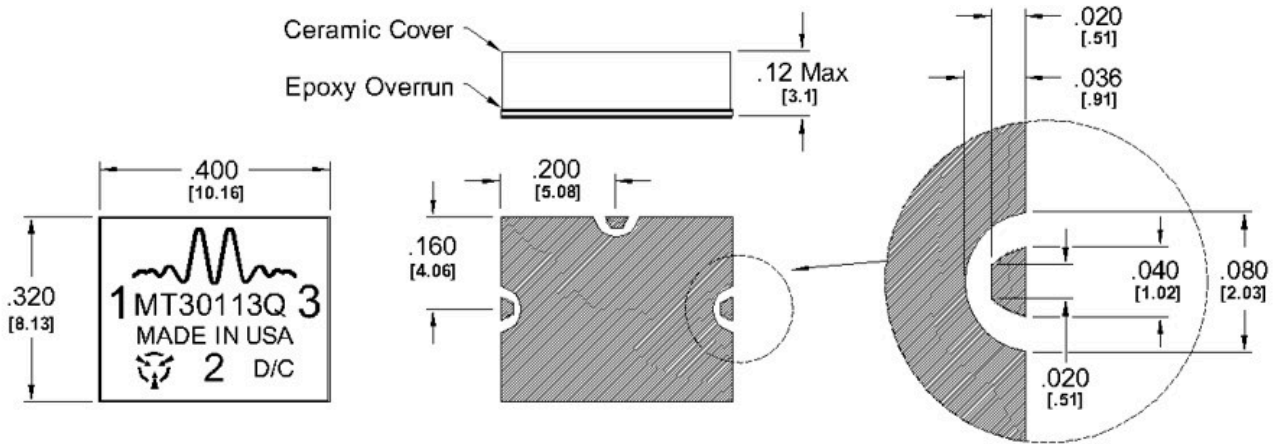

I/O Connections & Ground Plane Finish is Gold Flash, 5 to 10 μ -inches, over Solderable Nickel, 100-200 μ -inches, over Cu.

Footprint Image

Download : [Footprint Drawing](#)

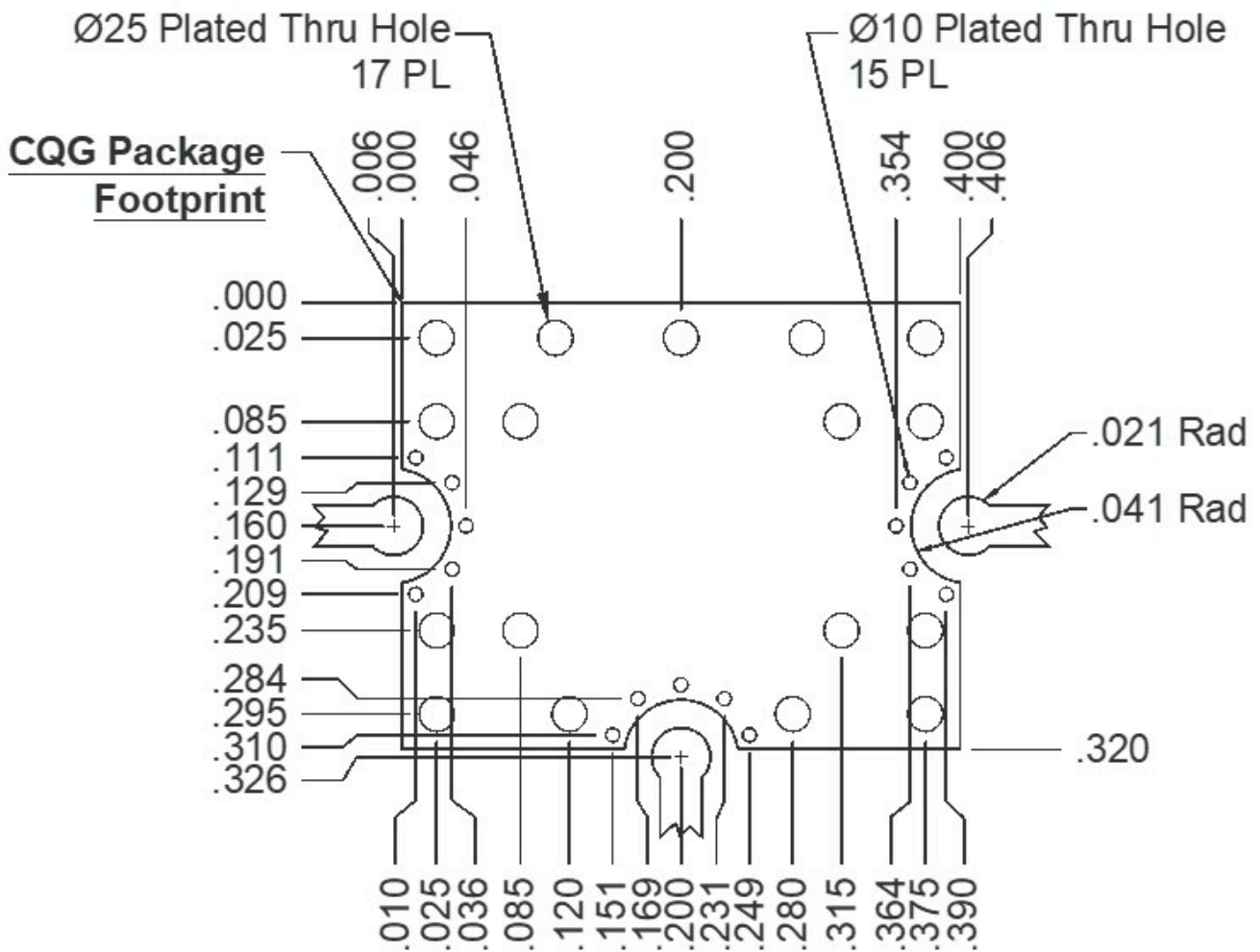

Notes

DATA SHEET NOTES:

1. Mixer Conversion Loss Plot IF frequency is 100 MHz unless otherwise specified.
2. Mixer Noise Figure typically measures within 0.5 dB of conversion loss for IF frequencies greater than 5 MHz.
3. Conversion Loss typically degrades less than 0.5 dB at +100°C and improves less than 0.5 dB at -40°C.
4. Unless otherwise specified, sine-wave data is taken with +27 dBm LO drive.
5. Specifications are subject to change without notice. Contact Marki Microwave for the most recent specifications and data sheets.
6. Catalog mixer circuits are continually improved. Configuration control requires custom mixer model numbers and specifications.

DISCLAIMER

MARKI MICROWAVE, INC., ("MARKI") PROVIDES TECHNICAL SPECIFICATIONS AND DATA (INCLUDING DATASHEETS), APPLICATION OR OTHER DESIGN ADVICE, WEB TOOLS, AND OTHER INFORMATION AND RESOURCES "AS IS" AND WITH ALL FAULTS. MARKI DISCLAIMS ALL WARRANTIES, EXPRESS OR IMPLIED, INCLUDING, WITHOUT LIMITATION, ANY IMPLIED WARRANTIES OF MERCHANTABILITY, FITNESS FOR A PARTICULAR PURPOSE, OR NON-INFRINGEMENT.

These resources are intended for developers skilled in the art designing with Marki products. You are solely responsible for (1) selecting the appropriate products for your application, (2) designing, validating, and testing your application, and (3) ensuring your application meets applicable standards and other requirements. Marki makes no guarantee regarding the suitability of its products for any particular purpose, nor does Marki assume any liability whatsoever arising out of your use or application of any Marki product.

Marki grants you permission to use these resources only for development of an application that uses Marki products. Other reproduction or use of these resources is strictly prohibited. No license is granted to any other Marki intellectual property or to any third-party intellectual property. Marki reserves the right to make changes to the product(s) or information contained herein without notice.

MARKI MICROWAVE and T3 MIXER are trademarks or registered trademarks of Marki Microwave, Inc. All other trademarks used are the property of their respective owners.

© 2019 - 2020, Marki Microwave, Inc