

# MT3A-0113HCSM

## Two-Tone-Terminator Mixer/LO Amplifier

### DEVICE OVERVIEW

#### General Description

The MT3A-0113HCSM is a versatile, robust, and broadband Two-Tone-Terminator mixer integrated with a low phase noise LO driver amplifier. The MT3A-0113HCSM employs the most sophisticated mixer on the market today and offers unparalleled performance when compared to all other mixer technologies. The MT3A-0113HCSM delivers exceptional IMD suppression with low conversion loss and high IP3. The integrated positive bias only LO amplifier allows for high linearity with LO drive levels down to just +5dBm.

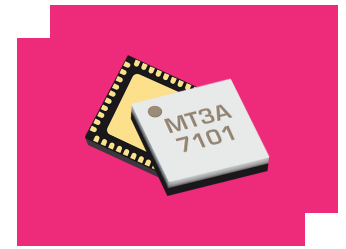

#### Features

- RF/LO response: 1.5GHz - 13 GHz
- IF response: 0.5 – 8.5 GHz
- Conversion Loss: 9.5 dB
- Minimum LO drive: +5 dBm

#### Applications

- Test and Measurement Equipment
- SATCOM
- Radar
- Electronic Warfare

#### Functional Block Diagram

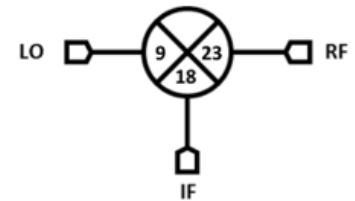

#### Part Ordering Options

Part Number	Description	Package	Green Status	Product Lifecycle	Export Classification
MT3A-0113HCSM	Two-Tone-Terminator Mixer/LO Amplifier	QFN	REACH RoHS	Released	EAR99
EVB-MT3A-0113HC	Evaluation Board, Two-Tone-Terminator 1.5 - 13 GHz Mixer.	EVB	Non-RoHS	Released	EAR99

**Table Of Contents**

- **Device Overview**
  - General Description
  - Features
  - Applications
  - Functional Block Diagram
- **Port Configuration and Functions**
  - Port Diagram
  - Port Functions
- **Revision History**
- **Specifications**
  - Absolute Maximum Ratings
  - Package Information
  - Recommended Operating Conditions
  - Electrical Specifications
  - Typical Performance Plots
  - Spur Tables
- **Operation**
  - Application Circuit
  - Application Circuit Description
- **Mechanical Data**
  - Outline Drawing
- **Footprint Image**
- **Evaluation Board**
  - Evaluation Board Outline Drawing
  - Evaluation Board - Application Circuit

**Revision History**

Revision Code	Revision Date	Comment
-	2021-10-01	Datasheet Initial Release



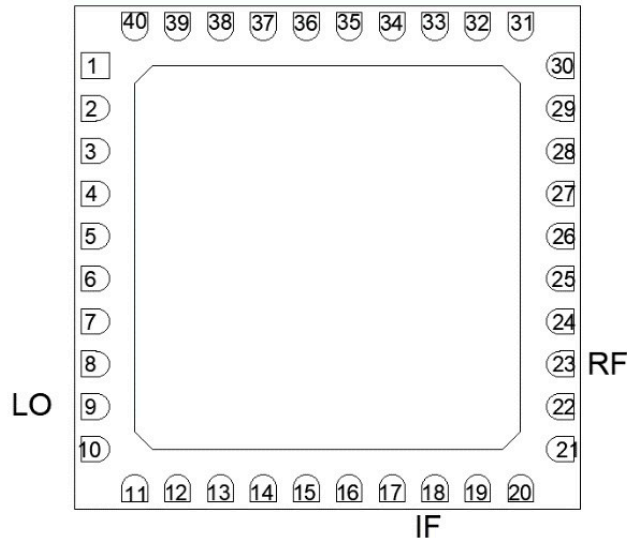

**Port Configuration and Functions**

**Port Diagram**

A top-down x-ray view of the MT3A-0113HCSM’s CSM Package outline drawing is shown below. The MT3A-0113HCSM has the input and output ports given in Port Functions.

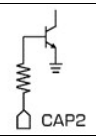
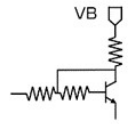

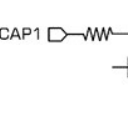
**Port Functions**

Port	Function	Description	DC Equivalent Circuit
GND	Ground	IC backside must be connected to a DC/RF ground with high thermal and electrical conductivity.	GND 
Pin 13	Cap 2	Pin 13 allows the user to attach additional off chip bypass capacitance to provide adequate low frequency AC grounding termination to the input matching network. The value should be at least 100nF.	
Pin 15	VB	Pin 15 is the DC voltage bias for the current mirror that controls collector current supplied to the amplifier. Larger voltages result in a higher current draw through port VC, effectively functioning as a gain control pin of the amplifier.	
Pin 18	IF	Pin 18 is DC blocked and AC matched to 50 Ohms from 500 MHz to 8.5 GHz.	IF 
Pin 23	RF	Pin 23 is DC short to ground and AC matched to 50 Ohms from 1.5 GHz to 13 GHz. Blocking capacitor is optional.	RF 
Pin 3	Cap 1	Pin 3 allows the user to attach additional off chip bypass capacitance to provide adequate low frequency AC grounding termination to the input matching network. The value should be at least 100nF.	CAP1 
Pin 38	VC	Pin 38 is the DC voltage supply that supplies the amplifier's collector current.	
Pin 9	LO	The LO port is DC blocked and AC matched to 50 Ohms from 1.5 GHz to 13 GHz.	LO 

## Specifications

### Absolute Maximum Ratings

The Absolute Maximum Ratings indicate limits beyond which damage may occur to the device. If these limits are exceeded, the device may be inoperable or have a reduced lifetime.

Parameter	Maximum Rating	Unit
DC Bias Current	150	mA
DC Voltage on VB or VC	8	V
LO Power Handling	15	dBm
Maximum Operating Temperature	85	°C
Maximum Storage Temperature	125	°C
Max Junction Temperature for MTTF > 1E6 hours	125	°C
Max Power Dissipation for MTTF of 1E6 hours at 85°C Baseplate Temperature	650	mW
Minimum Operating Temperature	-55	°C
Minimum Storage Temperature	-65	°C
RF Power Handling	25	dBm
θJC, Junction to Case Thermal Resistance	61	°C/W

### Package Information

Parameter	Details	Rating
ESD	250 to < 500 Volts	HBM Class 1A
Dimensions	-	6 x 6 mm
Moisture Sensitivity Level	-	MSL 1

### Recommended Operating Conditions

Parameter	Min	Nominal	Max	Unit
Ambient Temperature	55	25	85	°C
LO Input Power	5	12	15	dBm
Positive DC Voltage (VC) <sup>1</sup>	5	7	8	V
Positive DC Current Mirror Voltage (VB)	5	6	8	V
Current Draw	80	120	150	mA

<sup>[1]</sup> There is no sequencing required to apply DC or RF power to the mixer.

## Electrical Specifications

The electrical specifications apply at TA=+25°C in a 50Ω system. Typical data shown is for a down conversion application with a +12dBm sine wave LO input to the integrated LO driver amp biased at +6VB/+7VC.

Parameter	Test Conditions	Min	Typ	Max	Unit
IF Frequency Range	-	0.5	-	8.5	GHz
LO Frequency Range	-	1.5	-	13	GHz
RF Frequency Range	-	1.5	-	13	GHz
Conversion Loss <sup>1</sup>	RF/LO = 1.5 - 13 GHz I = 0.5 - 2 GHz	-	9.5	14	dB
Conversion Loss	RF/LO = 1.5 - 13 GHz I = 2 - 8.5 GHz	-	11.5	-	dB
Current Consumption	+6.0VB/+7.0VC	80	120	150	mA
Input IP3	RF/LO = 1.5 - 13 GHz I = 0.5 - 2 GHz	-	28	-	dBm
Input P0.1 dB	-	-	13	-	dBm
Noise Figure <sup>2</sup>	RF/LO = 1.5 - 13 GHz I = 0.5 - 2 GHz	-	10	-	dB

[1] Measured as a down converter to a fixed 1 GHz IF.

[2] Mixer Noise Figure typically measures within 0.5 dB of conversion loss for IF frequencies greater than 5 MHz.

**Typical Performance Plots**

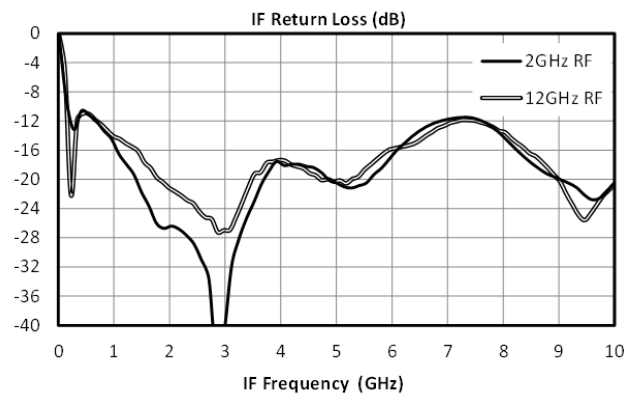
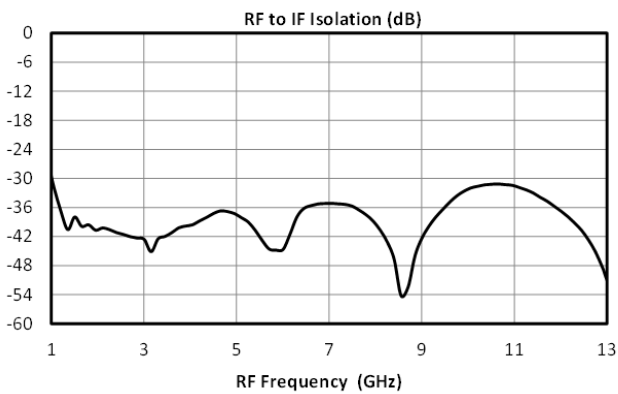
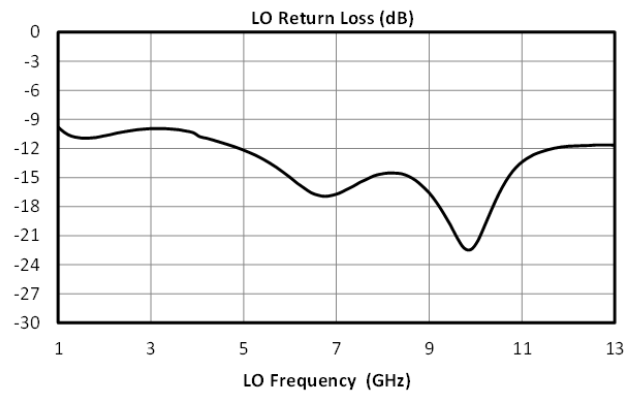
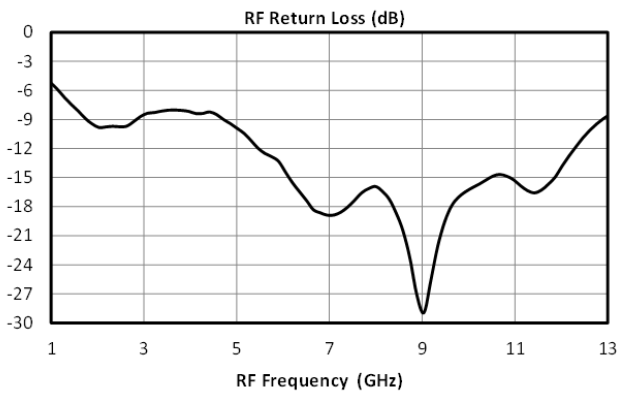
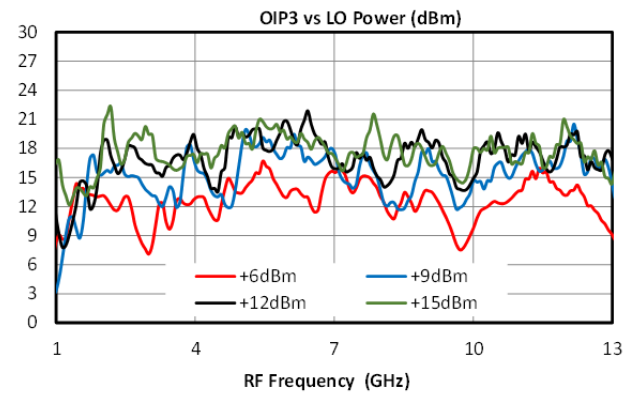
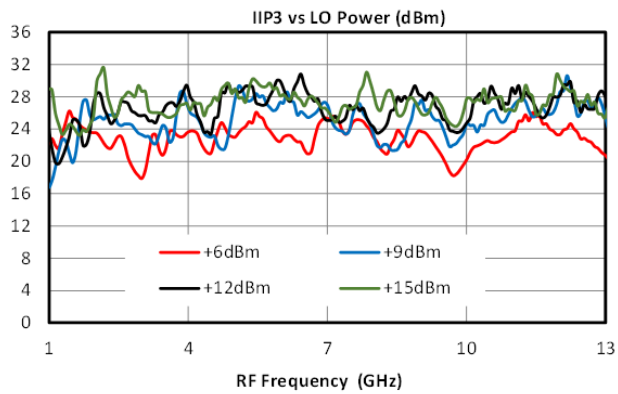
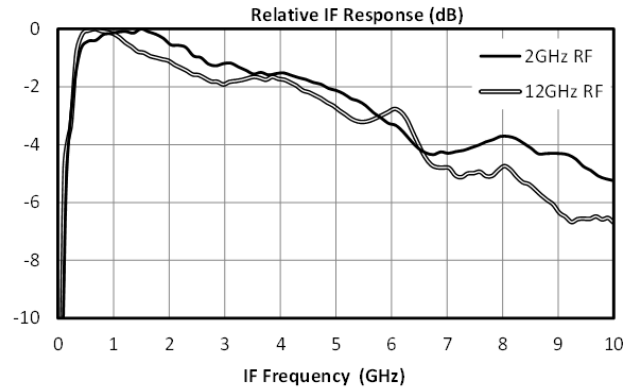
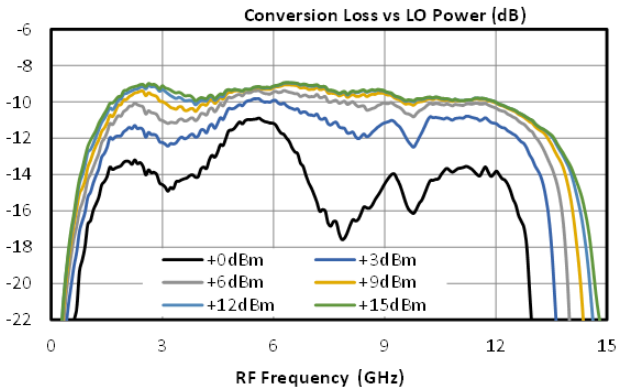

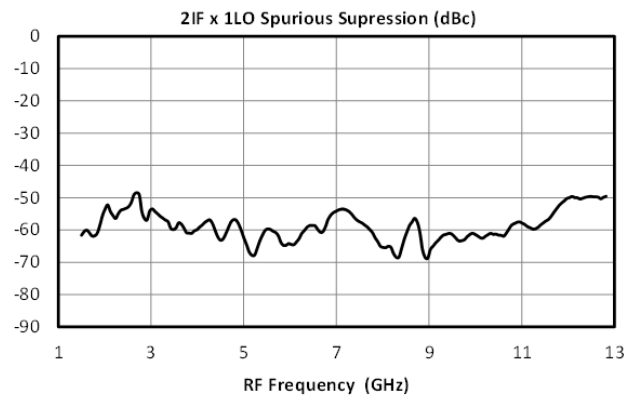
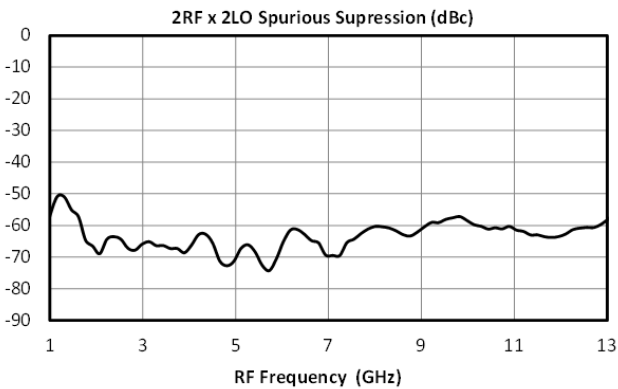
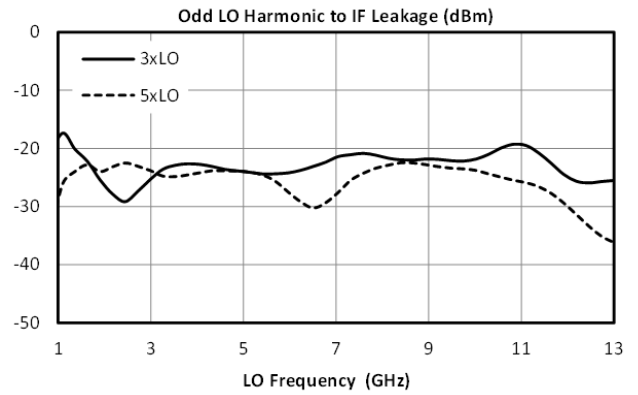
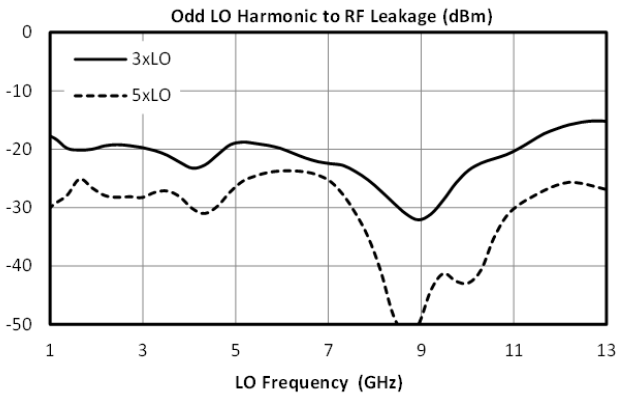
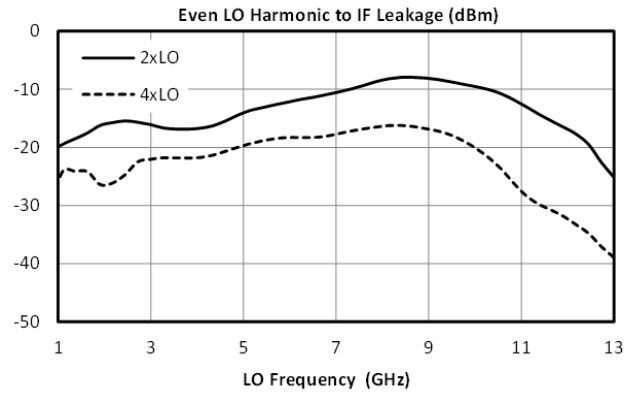
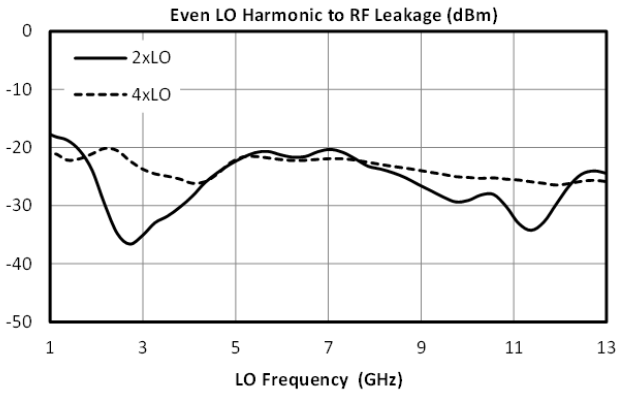
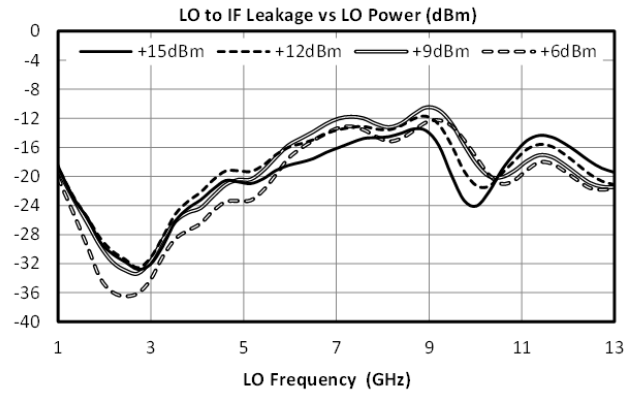
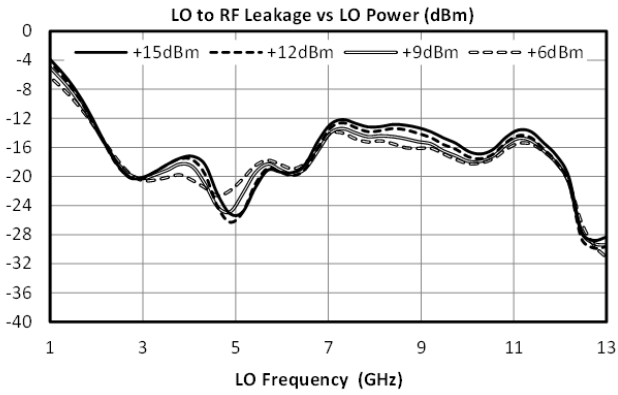

## Spur Table

### Typical Spurious Performance: Down-Conversion

Typical spurious data is provided by selecting RF and LO frequencies ( $\pm m \cdot LO \pm n \cdot RF$ ) within the RF/LO bands, to create a spurious output within the IF band. The mixer is swept across the full spurious band and the mean is calculated. The numbers shown in the table below are for a -10 dBm RF input. Spurious suppression is scaled for different RF power levels by  $(n-1)$ , where “n” is the RF spur order. For example, the  $2RF \times 2LO$  spur is 63 dBc for a -10 dBm input, so a -20 dBm RF input creates a spur that is  $(2-1) \times (-10 \text{ dB})$  lower, or 73 dBc. Data is shown for the frequency plan in Typical Performance section.  $mLO \pm nRF$  plots can be found in section 3.6.2.  $0LO \pm 1RF$  plot is identical to the plot of LO-RF isolation.

**Typical Down-conversion spurious suppression (dBc)**

-10 dBm RF Input	0xLO	1xLO	2xLO	3xLO	4xLO	5xLO
1xRF	23	Reference	21	18	18	20
2xRF	64	65	63	41	63	62
3xRF	95	81	57	80	83	84
4xRF	103	115	111	112	112	112
5xRF	128	132	129	129	129	129

**Typical Spurious Performance: Up-Conversion**

Typical spurious data is taken by mixing an input within the IF band, with LO frequencies ( $\pm m \cdot LO \pm n \cdot IF$ ), to create a spurious output within the RF output band. The mixer is swept across the full spurious output band and the mean is calculated. The numbers shown in the table below are for a -10 dBm IF input. Spurious suppression is scaled for different IF input power levels by (n-1), where “n” is the IF spur order. For example, the 2IFx1LO spur is typically 63 dBc for a -10 dBm input with a sine-wave LO, so a -20 dBm IF input creates a spur that is (2-1) x (-10 dB) lower, or 73 dBc. Data is shown for the frequency plan in Typical Performance section.

**Typical Up-conversion spurious suppression (dBc)**

-10 dBm IF Input	0xLO	1xLO	2xLO	3xLO	4xLO	5xLO
1xIF	22	Reference	20	18	18	24
2xIF	67	63	66	41	63	53
3xIF	92	81	56	78	75	73
4xIF	116	109	114	107	108	101
5xIF	127	124	127	120	123	118

**Application Circuit**

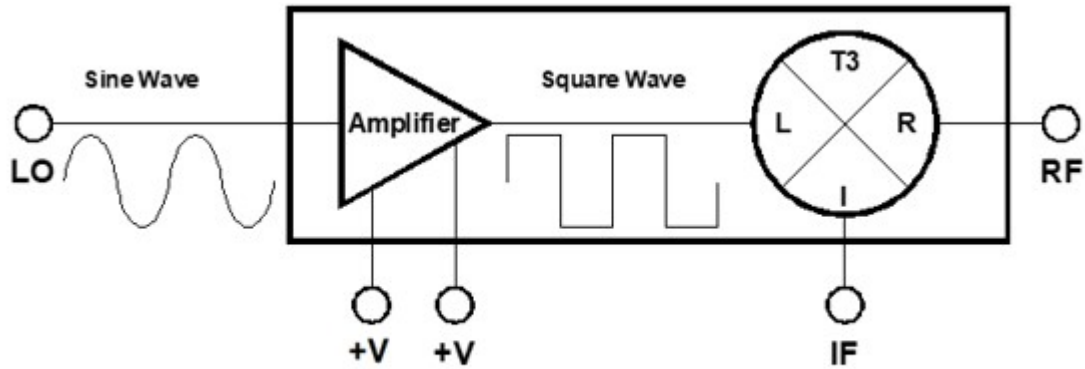

See T3 Mixer Primer for benefits of square wave LO drive with T3 mixers

## Application Circuit Description

### Ports Operation

**IF Port** – Used as input on an upconversion, output on downconversion, or LO port in a band shifting application. Signals should be connected by 50 ohm microstrip or coplanar traces to well matched broadband 50 ohm sources and loads.

**RF Port** – Used as input on a downconversion, output on upconversion, or output in a band shifting application. Signals should be connected by 50 ohm microstrip or coplanar traces to well matched broadband 50 ohm sources and loads.

**LO Port** – The noise floor of the LO input signal should be less than the value of the noise floor plus isolation of the mixer, or a filter is recommended to prevent reduction in dynamic range. An integrated LO amplifier is included, allowing for superior performance with LO power below the typical recommended drive level.

**Filtering and Matching** – Filtering is generally desired for spurious and image removal on the output port of the mixer. Reflective filters can cause out of band signals to reflect back into the mixer and cause conversion loss ripple, erroneous spurs, and other undesired behaviors. To eliminate these problems it is recommended that the filters be placed as close to the output port as possible. If undesired behavior is still observed, a diplexer with one port terminated or a 1-3 dB attenuator may reduce this problem.

**RF Ground**– The ground paddle of the QFN should be connected to a low noise RF ground with very low electrical resistance for high frequency operation.

### Mechanical Data

### Outline Drawing

Download : [Outline 3D Drawing](#) | [Outline 3D STP](#)

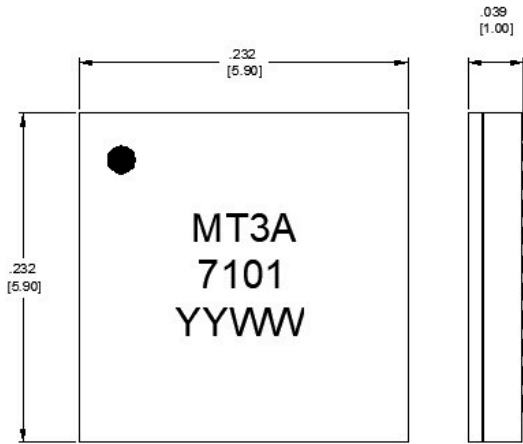

Finish: ENEPIG		
Ni	8.89µm MAX	1.27µm MIN
Pd	0.17µm MAX	0.07µm MIN
Au	0.254µm MAX	0.03µm MIN

Table A

Notes (unless otherwise specified):

1. Substrate material is Ceramic.
2. All unconnected pins should be connected to PCB RF ground.

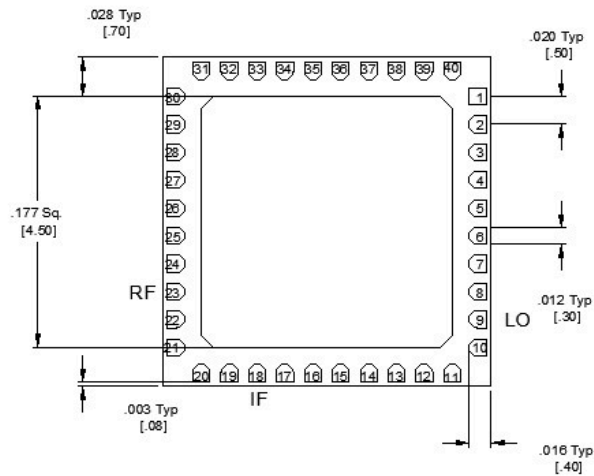

Pad #	Function
1	N/C
2	N/C
3	Cap 1
4	N/C
5	N/C
6	N/C
7	N/C
8	N/C
9	LO
10	N/C
11	N/C
12	N/C
13	Cap 2
14	N/C
15	VB
16	N/C
17	N/C
18	IF
19	N/C
20	N/C
21	N/C
22	N/C
23	RF
24	N/C
25	N/C
26	N/C
27	N/C
28	N/C
29	N/C
30	N/C
31	N/C
32	N/C
33	N/C
34	N/C
35	N/C
36	N/C
37	N/C
38	VC
39	N/C
40	N/C

## MT3A-0113HCSM

### Two-Tone-Terminator Mixer/LO Amplifier

#### Footprint Image

QFN 6mm Plastic Sample Drawing  
X-Ray view

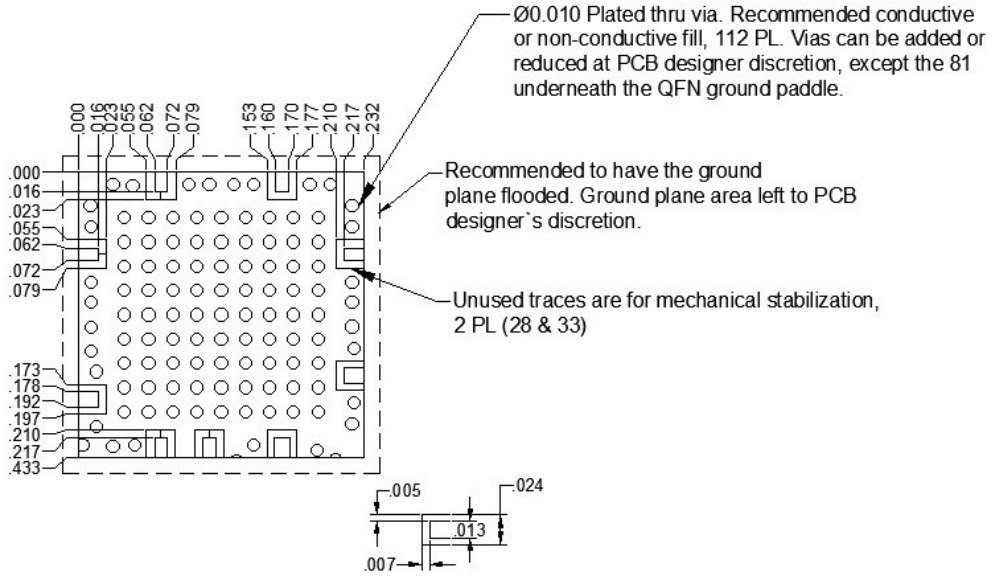
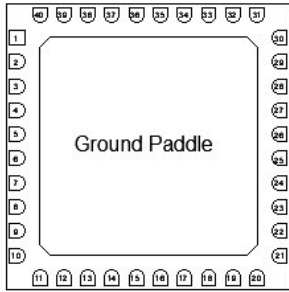

Material Rogers 4003 008"  $\frac{1}{2}$  Oz Cu both sides.

### Evaluation Board - Outline Drawing

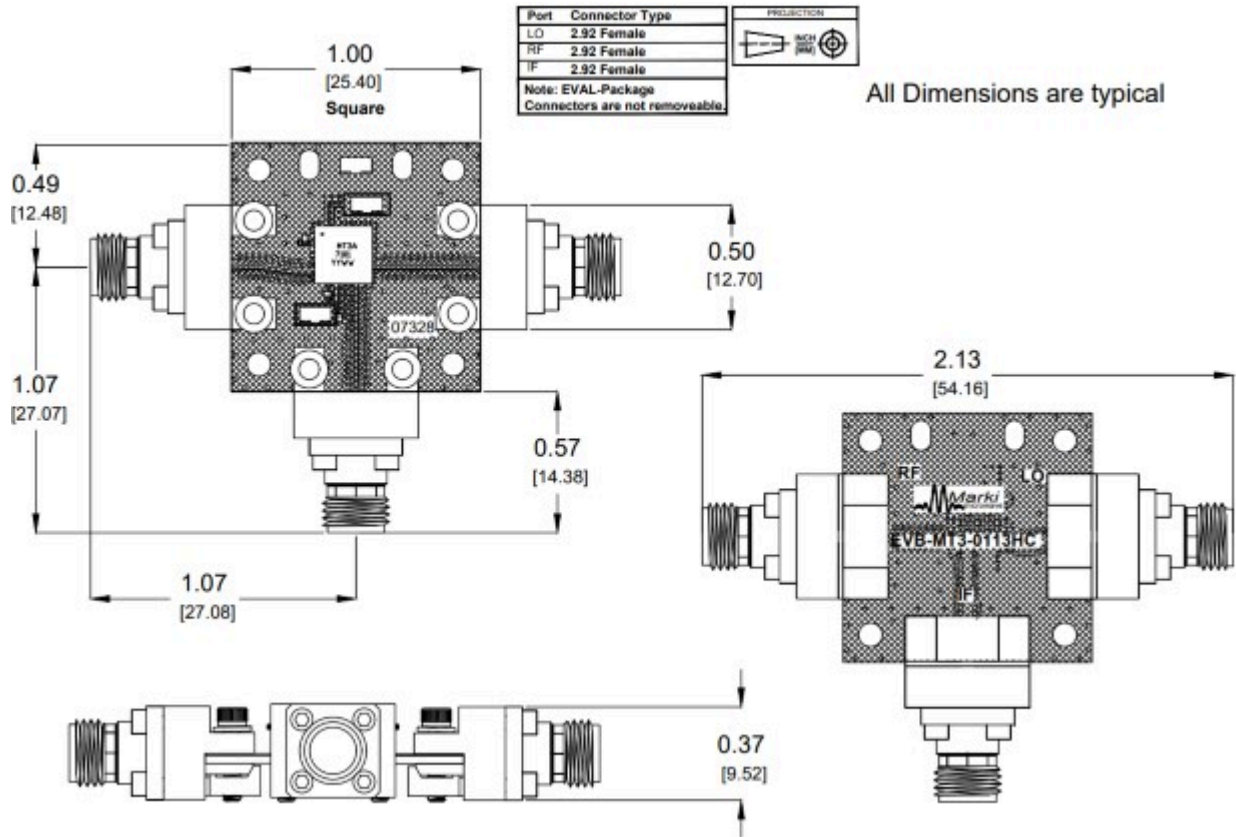

**Evaluation Board - Application Circuit**

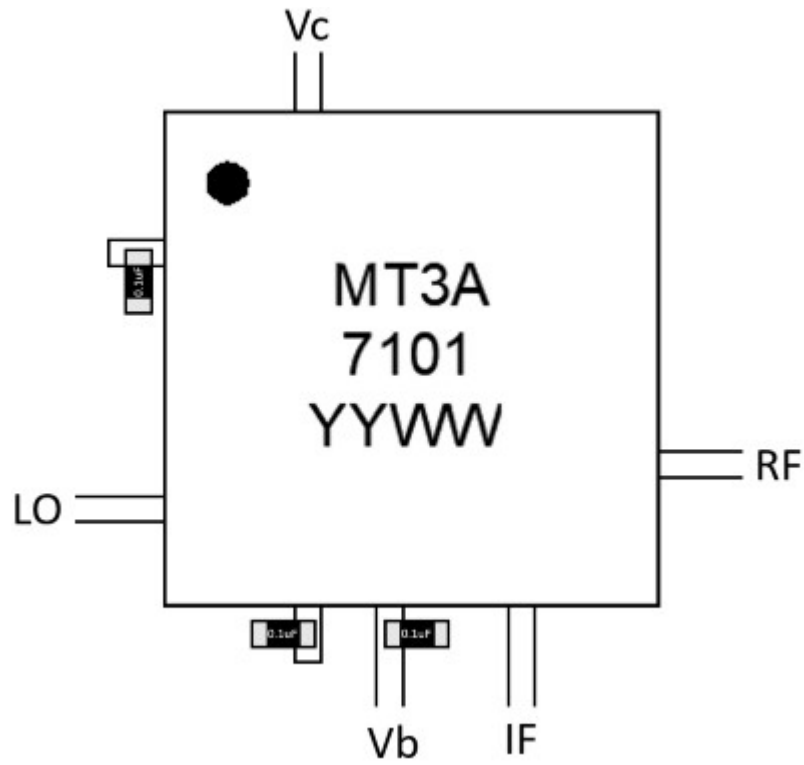

**DISCLAIMER**

MARKI MICROWAVE, LLC., ("MARKI") PROVIDES TECHNICAL SPECIFICATIONS AND DATA (INCLUDING DATASHEETS), APPLICATION OR OTHER DESIGN ADVICE, WEB TOOLS, AND OTHER INFORMATION AND RESOURCES "AS IS" AND WITH ALL FAULTS. MARKI DISCLAIMS ALL WARRANTIES, EXPRESS OR IMPLIED, INCLUDING, WITHOUT LIMITATION, ANY IMPLIED WARRANTIES OF MERCHANTABILITY, FITNESS FOR A PARTICULAR PURPOSE, OR NON-INFRINGEMENT.

These resources are intended for developers skilled in the art designing with Marki products. You are solely responsible for (1) selecting the appropriate products for your application, (2) designing, validating, and testing your application, and (3) ensuring your application meets applicable standards and other requirements. Marki makes no guarantee regarding the suitability of its products for any particular purpose, nor does Marki assume any liability whatsoever arising out of your use or application of any Marki product.

Marki grants you permission to use these resources only for development of an application that uses Marki products. Other reproduction or use of these resources is strictly prohibited. No license is granted to any other Marki intellectual property or to any third-party intellectual property. Marki reserves the right to make changes to the product(s) or information contained herein without notice.

MARKI MICROWAVE and T3 MIXER are trademarks or registered trademarks of Marki Microwave, LLC. All other trademarks used are the property of their respective owners.

© 2021, Marki Microwave, LLC