

ABSD-10169PSM

30 GHz Single Ended to Differential Active Balun

DEVICE OVERVIEW

General Description

The ABSD-10169PSM is a GaAs active MMIC balun in a 3mm QFN surface mount package. Its frequency ranges from DC to 30 GHz and offers 9 dB single ended to differential gain (low end limited by DC block). The 3mm QFN package is a lead free, RoHS compliant package compatible with standard leaded and lead-free solder reflows. Connectorized evaluation packages are available. The ABSD-10168PSM is an excellent choice for active single ended to differential mode conversion and higher order Nyquist sampling in analog to digital converters.

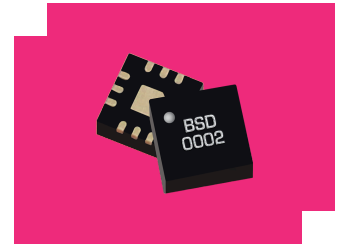

[Download s-parameters here](#)

Features

- 2:1 Impedance Ratio
- 30 GHz Active Balun (Single Ended to Differential Mode Conversion)
- Designed for Optimal Phase/Amplitude Balance
- 9 dB Single Ended to Differential Gain
- RoHS Compliant

Applications

- High-Speed Data
- Analog to Digital Converters
- Digital to Analog Converters

Functional Block Diagram

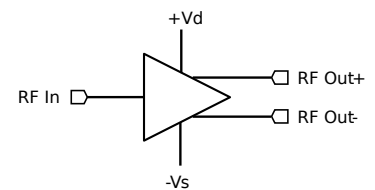

Part Ordering Options

Part Number	Description	Package	Green Status	Product Lifecycle	Export Classification
ABSD-10169PSM	30 GHz Single Ended to Differential Active Balun	QFN	REACH RoHS	Released	EAR99
EVB-ABSD-10169P	Evaluation Board	EVB	REACH RoHS	Released	EAR99

Table Of Contents

- **Device Overview**
 - General Description
 - Features
 - Applications
 - Functional Block Diagram
- **Port Configuration and Functions**
 - Port Diagram
 - Port Functions
- **Revision History**
- **Specifications**
 - Absolute Maximum Ratings
 - Package Information
 - Recommended Operating Conditions
 - Electrical Specifications
 - Typical Performance Plots
 - Differential Linearity
 - Differential Noise Figure
- **Operation**
 - Application Circuit
 - Application Circuit Description
- **Mechanical Data**
 - Outline Drawing
- **Footprint Image**
- **Evaluation Board**
 - Evaluation Board Outline Drawing
- **Notes**

Revision History

Revision Code	Revision Date	Comment
-	2025-04-07	Initial Release
A	2025-05-23	Corrected absolute max current rating

Port Configuration and Functions

Port Diagram

Below is the port diagram for the ABSD-10169PSM. The diagram is shown as an x-ray view from the top down.

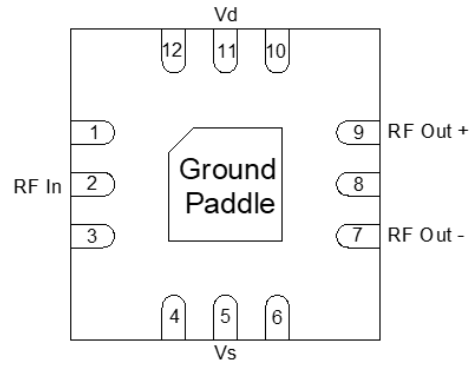

Port Functions

Port	Function	Description	DC Equivalent Circuit
11	Vd	Pin 11 is the positive DC supply voltage for the device.	-
1,3,4,6,8,10 and 12	Non-connect (NC)	These pins are not connected internally. Datasheet performance is tested with NC pins grounded.	-
2	RF Input	Pin 2 is the RF input of the device. This pin is internally RF matched to 50 Ohms and is DC coupled. This pin requires an external DC blocking capacitor if there is DC present on the input line. If no DC is present or the line is floating, an external DC blocking capacitor is unnecessary.	-
5	Vs	Pin 5 is the negative DC supply voltage for the device.	-
7	RF Out -	Pin 7 is the negative RF output of the device. This pin is internally RF matched to 50 Ohms and is DC coupled. This pin requires an external DC blocking capacitor.	-
9	RF Out +	Pin 9 is the positive RF output of the device. This pin is internally RF matched to 50 Ohms and is DC coupled. This pin requires an external DC blocking capacitor.	-
Paddle	Ground	Ground pad should be connected to RF/DC ground with low electrical and thermal resistance.	-

Specifications

Absolute Maximum Ratings

The Absolute Maximum Ratings indicate limits beyond which damage may occur to the device. If these limits are exceeded, the device may be inoperable or have a reduced lifetime. This device is designed and characterized in a 50Ω system (100Ω differential output), and operation in a reflective environment can cause performance degradation.

Parameter	Maximum Rating	Unit
Drain Current (Id) (No RF Applied) ¹	160	mA
Maximum Operating Temperature	85	°C
Maximum Storage Temperature	150	°C
Minimum Operating Temperature	-40	°C
Minimum Storage Temperature	-65	°C
RF Input Power	10	dBm
Total DC Supply Voltage (Vd-Vs)	11	V

^[1] Max current density across TFR

Package Information

Parameter	Details	Rating
ESD	< 50 Volts	HBM 0Z
Dimensions	-	3 x 3 mm
Moisture Sensitivity Level	-	MSL 1

Recommended Operating Conditions

Parameter	Min	Nominal	Max	Unit
Negative DC Voltage (Vs)	-4	-5	-5	V
Negative DC Current (Is) (No RF Input)	-94	-116	-116	mA
Positive DC Current (Id) (No RF Input)	111	137	137	mA
Positive DC Voltage (Vd)	4	5	5	V

Electrical Specifications

Specifications guaranteed for +25°C, measured in a 50Ω system. Measured data was taken on an evaluation board and includes PCB trace and connector effects unless otherwise noted.

Parameter	Test Conditions	Minimum Frequency (GHz)	Maximum Frequency (GHz)	Min	Typ	Max	Unit
Single-Ended Gain ¹	Vd=5V, Vs=-5V	0	30	-	6	-	dB
Differential Power Gain ²	Vd=5V, Vs=-5V	0	30	-	9	-	dB
Common Port Return Loss ³	Vd=5V, Vs=-5V	0	30	-	22	-	dB
Output Return Loss ⁴	Vd=5V, Vs=-5V	0	30	-	22	-	dB
Amplitude Balance	Vd=5V, Vs=-5V	0	30	-	0.1	-	dB
Phase Balance	Vd=5V, Vs=-5V	0	30	-	1	-	°
Nominal Phase Shift	Vd=5V, Vs=-5V	0	30	-	180	-	°
Common Mode Rejection	Vd=5V, Vs=-5V	0	30	-	40	-	dB
Reverse Isolation ⁵	Vd=5V, Vs=-5V	0	30	-	55	-	dB
Noise Figure ⁶	Vd=5V, Vs=-5V	0	30	-	9	-	dB
HD2	Vd=5V, Vs=-5V, differential output power=+3dBm	0	20	-	-52	-	dBc
HD3	Vd=5V, Vs=-5V, differential output power=+3dBm	0	13	-	-37	-	dBc
Output IP2	Vd=5V, Vs=-5V, Pin=+7dBm, Tone Spacing = 10MHz	0	20	-	55	-	dBm
Output IP3	Vd=5V, Vs=-5V, Pin=+7dBm, Tone Spacing = 10MHz	0	30	-	19	-	dBm
DC Supply Quiescent Current (Idq)	Vd=5V, Vs=-5V	-	-	-	137	-	mA
DC Supply Quiescent Current (Isq)	Vd=5V, Vs=-5V	-	-	-	-116	-	mA
Impedance Ratio	-	-	-	-	2:1	-	

[1][3][4][5] Measured single-ended with connector and evb effects de-embedded.

[2] Calculated as [(RF Out+) - (RF Out-)] relative to RF In.

[6] Measured using a balun at the output to re-combine the RF Out + and RF Out - signals. The external balun and associated losses are de-embedded from the measurement. EVB trace and connector losses are still present in the data.

Typical Performance Plots

Three port scattering parameters measured as three single-ended 50Ω ports. Small signal gain, return losses and reverse isolation have evb and connector effects de-embedded.

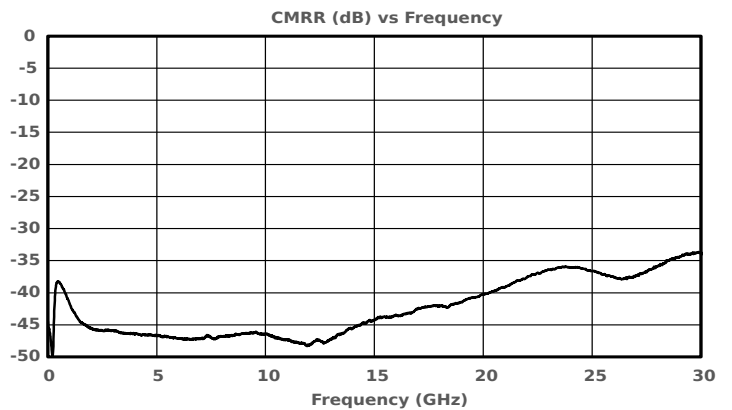
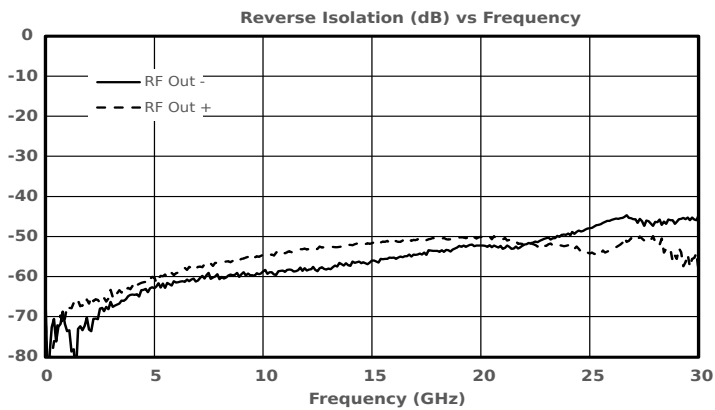
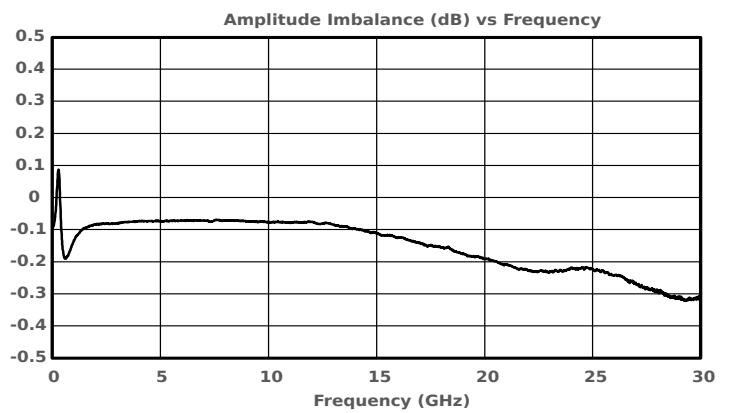
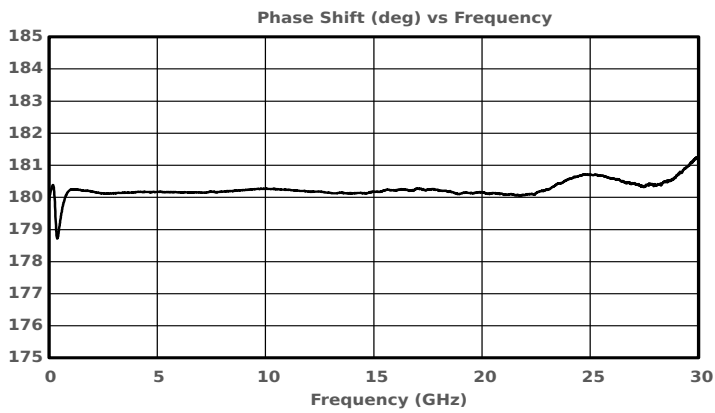
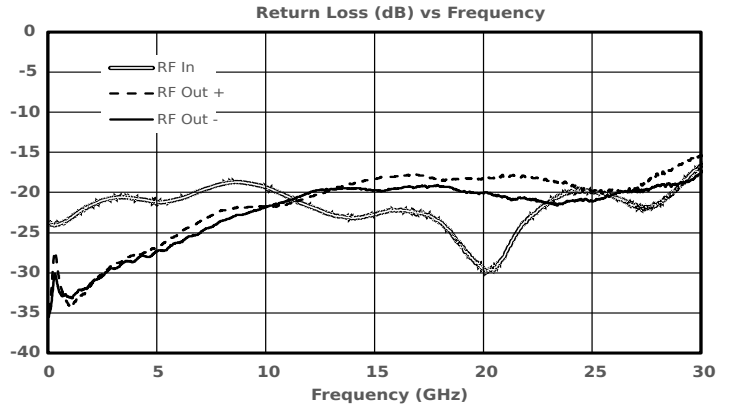
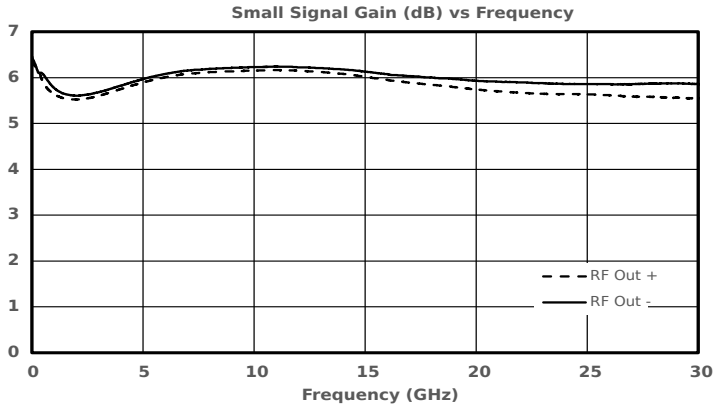

Differential Linearity

Measurements are with 50-Ω single-ended input, and 100-Ω differential output. EVB and connector effects are included in these measurements.

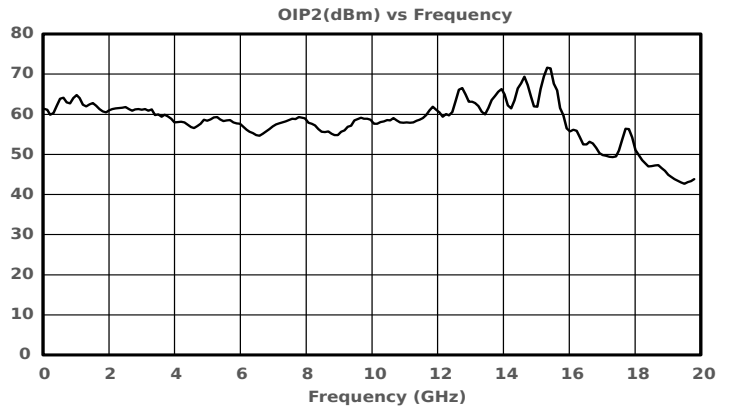
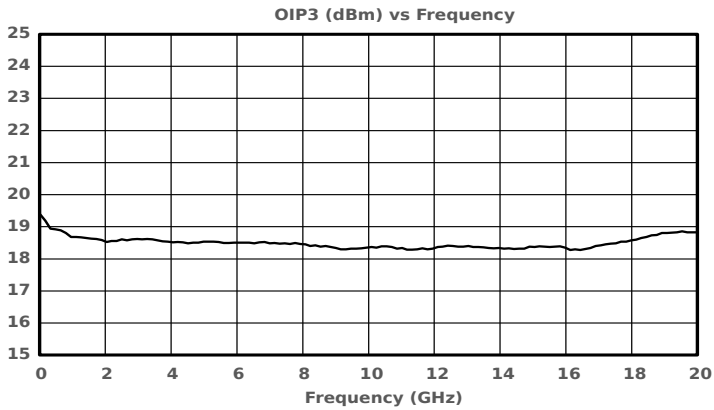
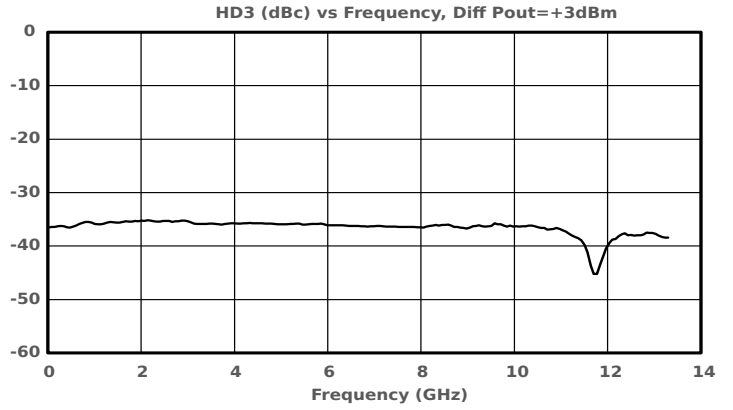
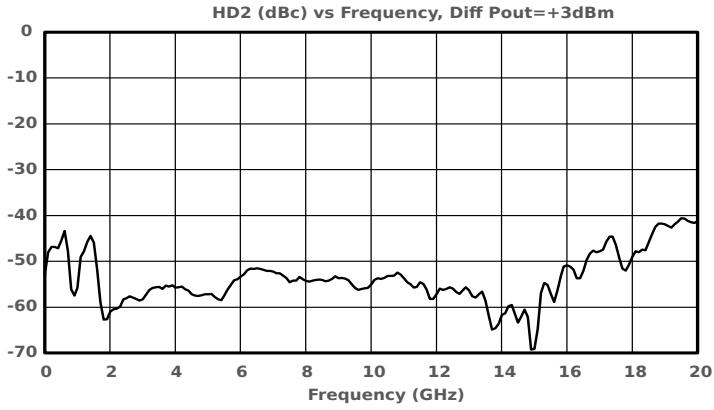

Differential Noise Figure

Measured differentially and includes EVB and connector noise contributions.

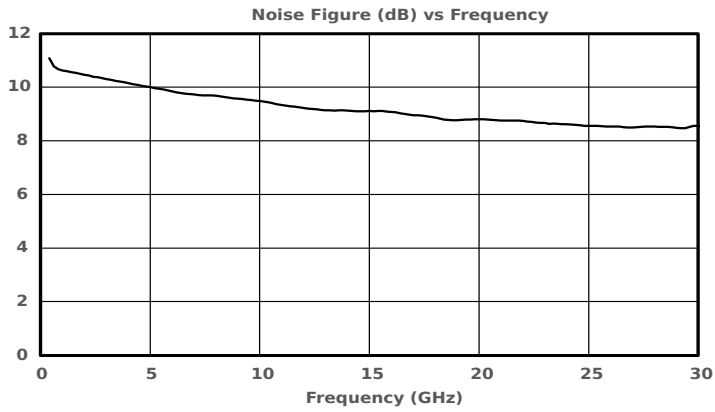

Application Circuit

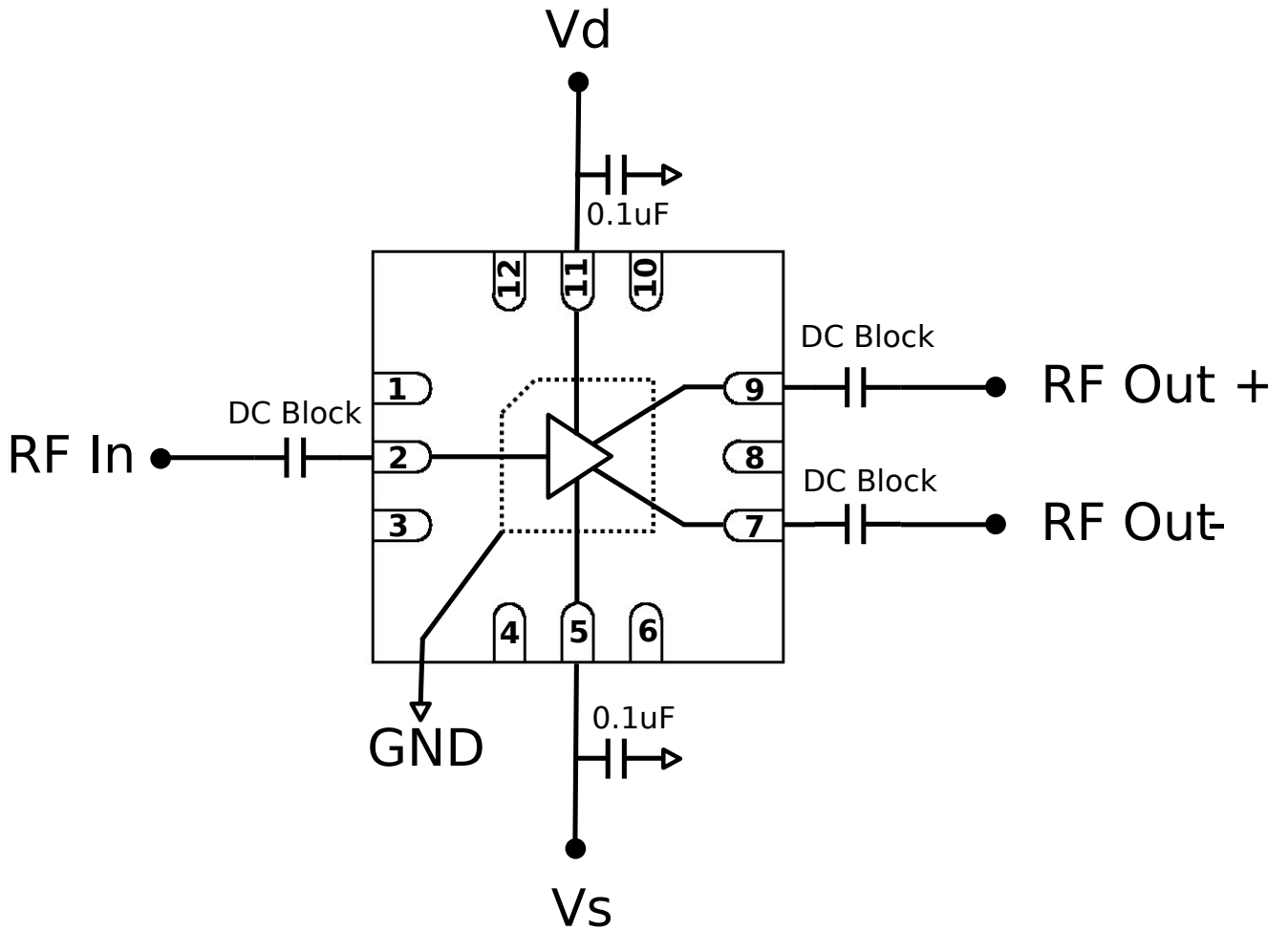

ABSD-10169PSM

30 GHz Single Ended to Differential Active Balun

Application Circuit Description

The application circuit for the ABSD-10169PSM is shown above. This part requires DC blocking capacitors at all RF pins (2,7 and 9). DC power is supplied via Vd (11) and Vs (5) pins. Positive DC voltage is applied to Vd and negative DC voltage is applied to Vs. It is recommended to provide 0.1uF bypass capacitors on the Vd and Vs supply lines. NC pins are not internally connected but should be grounded. The paddle of the QFN should be connected to GND via a low thermal and electrical resistance.

Mechanical Data

Outline Drawing

Download : [Outline 2D Drawing](#) | [Outline 3D Drawing](#) | [Outline 3D STP](#)

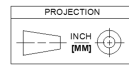
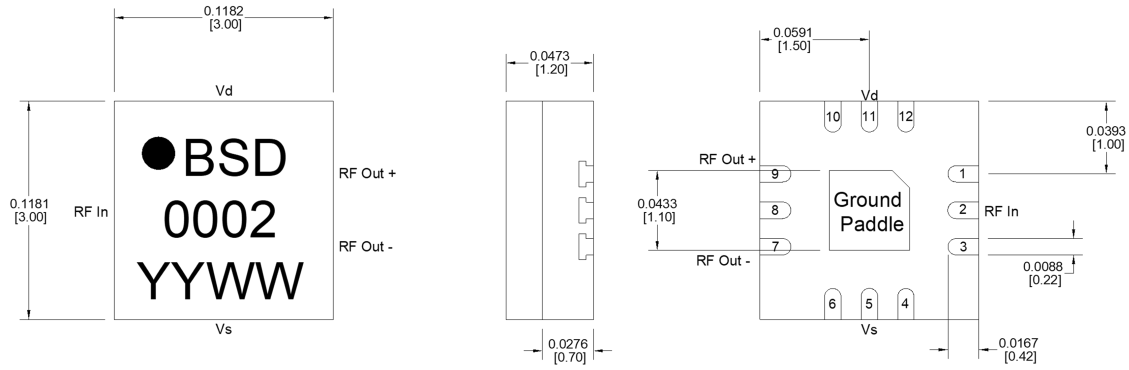

All dimensions are typical

Notes (unless otherwise specified):

1. Substrate material is LCP.
2. I/O Leads and Die Paddle are 0.05 micron Au over 0.02 microns Pd over 0.5 microns Ni.
3. All unconnected pins should be connected to PCB RF ground.

Pad #	Function
1	N/C
2	RF In
3	N/C
4	N/C
5	Vs
6	N/C
7	RF Out -
8	N/C
9	RF Out +
10	N/C
11	Vd
12	N/C

Footprint Image

Download : [Footprint Drawing](#)

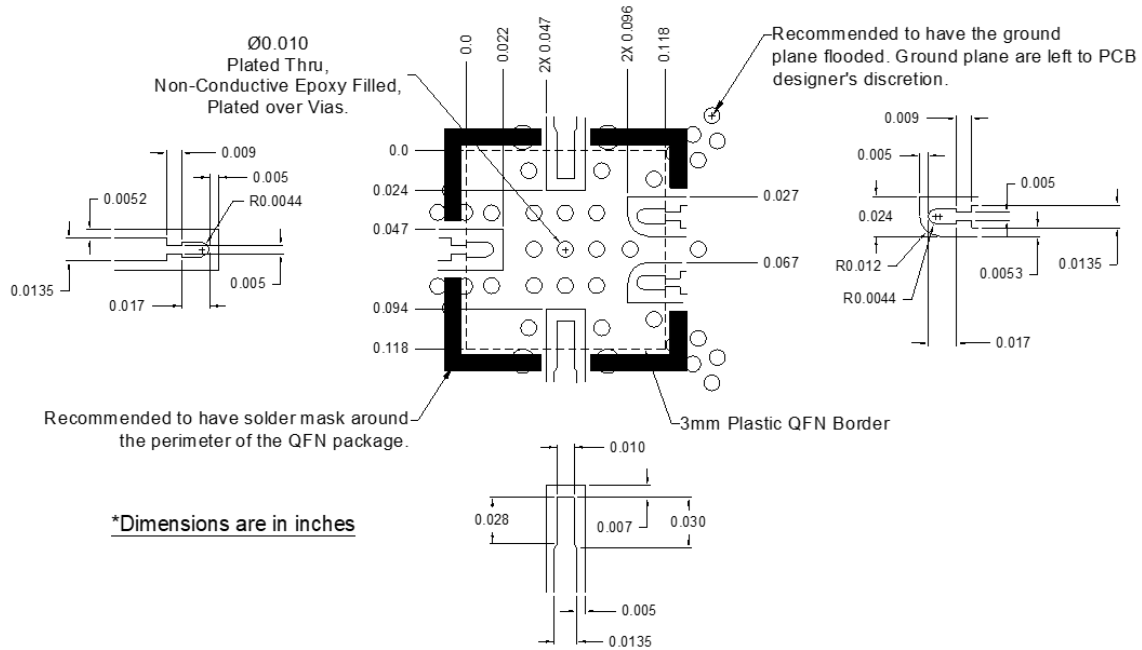

The landing pattern is to be used on Rogers 4003, 0.008" thick, $\frac{1}{2}$ Oz Cu both sides.

Evaluation Board - Outline Drawing

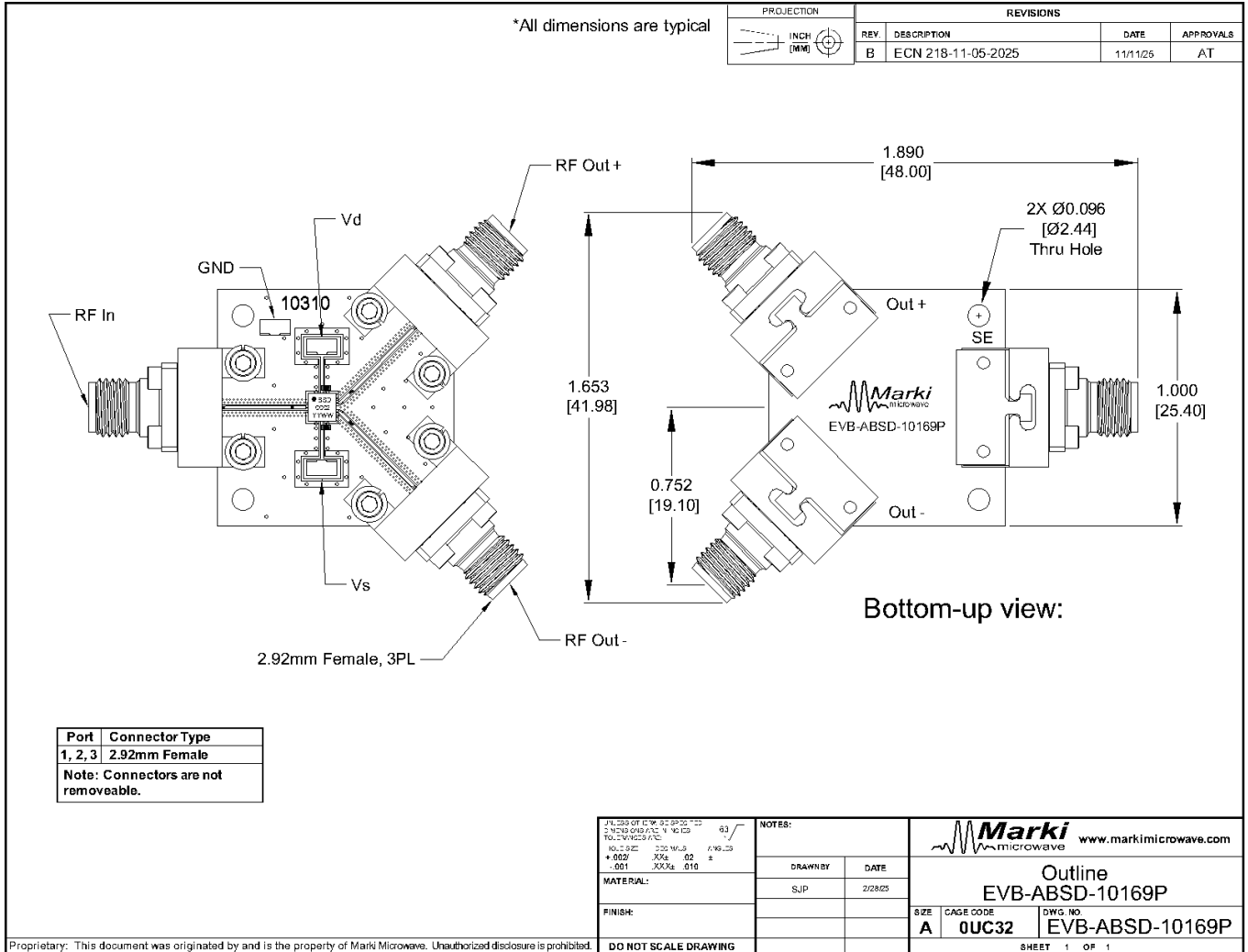

Notes

The RF transitions on the input and output traces of the recommended footprint are specific to the material type and thickness used on the Marki evaluation board. They are currently designed for single-ended 50 Ohm transmission line. They will need to be re-designed for pcb stackups using different materials and or different transmission line impedances.

DISCLAIMER

MARKI MICROWAVE, LLC., ("MARKI") PROVIDES TECHNICAL SPECIFICATIONS AND DATA (INCLUDING DATASHEETS), APPLICATION OR OTHER DESIGN ADVICE, WEB TOOLS, AND OTHER INFORMATION AND RESOURCES "AS IS" AND WITH ALL FAULTS. MARKI DISCLAIMS ALL WARRANTIES, EXPRESS OR IMPLIED, INCLUDING, WITHOUT LIMITATION, ANY IMPLIED WARRANTIES OF MERCHANTABILITY, FITNESS FOR A PARTICULAR PURPOSE, OR NON-INFRINGEMENT.

These resources are intended for developers skilled in the art designing with Marki products. You are solely responsible for (1) selecting the appropriate products for your application, (2) designing, validating, and testing your application, and (3) ensuring your application meets applicable standards and other requirements. Marki makes no guarantee regarding the suitability of its products for any particular purpose, nor does Marki assume any liability whatsoever arising out of your use or application of any Marki product.

Marki grants you permission to use these resources only for development of an application that uses Marki products. Other reproduction or use of these resources is strictly prohibited. No license is granted to any other Marki intellectual property or to any third-party intellectual property. Marki reserves the right to make changes to the product(s) or information contained herein without notice.

MARKI MICROWAVE and T3 MIXER are trademarks or registered trademarks of Marki Microwave, LLC. All other trademarks used are the property of their respective owners.

© 2025, Marki Microwave, LLC