

AMM-7200ACH

12 GHz – 46 GHz GaAs Driver Amplifier

DEVICE OVERVIEW

General Description

The AMM-7200ACH is a general-purpose broadband MMIC driver amplifier that provides +20 dBm output power suitable for driving a Marki H or L diode mixer at 12-46 GHz and S diode mixer from 14-40 GHz with low current consumption. The amplifier also has excellent return losses and a small die size which allows it to be used in a variety of applications. It has built in DC-blocking capacitors on the input and output.

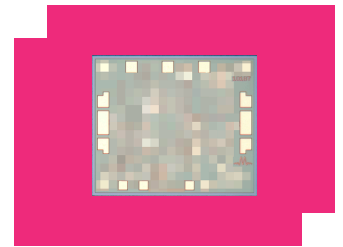

[Download s-parameters here](#)

Features

- +20 dBm Output Power
- 18 dB gain
- Excellent Return Losses
- Small Die size

Applications

- Mobile test and measurement equipment
- Radar
- SATCOM
- 5G transceivers
- Driver amplifier L,H,S – diode mixers

Functional Block Diagram

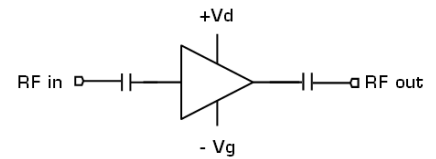

Part Ordering Options

Part Number	Description	Package	Green Status	Product Lifecycle	Export Classification
AMM-7200ACH	12 GHz – 46 GHz GaAs Driver Amplifier	CH	REACH RoHS	Released	3A001.b.2.d

Table Of Contents

- **Device Overview**
 - General Description
 - Features
 - Applications
 - Functional Block Diagram
- **Port Configuration and Functions**
 - Port Diagram
 - Port Functions
- **Revision History**
- **Specifications**
 - Absolute Maximum Ratings
 - Fit and MTTF Table
 - Package Information
 - Recommended Operating Conditions
 - Sequencing Requirements
 - Electrical Specifications
 - Typical Performance Plots
- **Operation**
 - Application Information
 - Application Circuit
 - Application Circuit Description
- **Mechanical Data**
 - Outline Drawing

Revision History

Revision Code	Revision Date	Comment
-	2024-09-10	Initial Release
A	2025-04-02	Outline Drawing update
B	2026-02-13	MTTF Table Added.

Port Configuration and Functions

Port Diagram

A port diagram of the AMM-7200ACH is shown below.

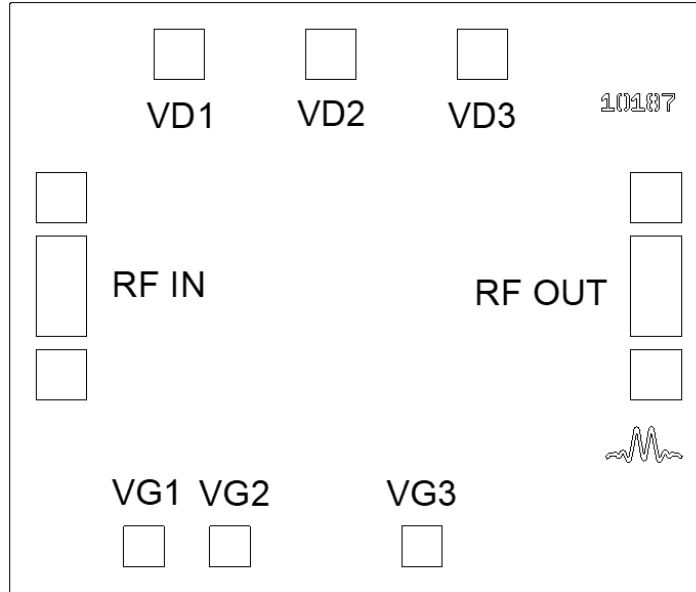

Port Functions

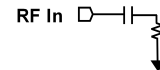
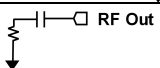
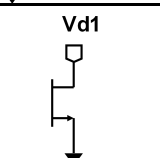
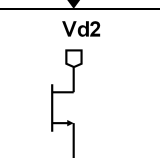
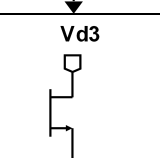
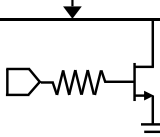
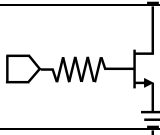
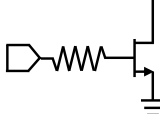
Port	Function	Description	DC Equivalent Circuit
GND	Ground	Ground is provided through the backside of the die. The backside of the die must be connected to a DC/RF ground with high thermal and electrical conductivity.	GND 
RF In	RF Input	This is the RF Input port of the amplifier die. It is internally DC blocked and RF matched to 50 Ω. RF input pad is GSG with 175 μm pitch.	
RF Out	RF Output	This is the RF Output port of the amplifier die. It is internally DC blocked and RF matched to 50 Ω. RF output pad is GSG with 175 μm pitch.	
VD1	Drain Supply Voltage	Pad VD1 supplies the drain voltage to the first stage of the 3-stage amplifier IC. Apply gate voltage to VG pins before applying drain voltage.	
VD2	Drain Supply Voltage	Pad VD2 supplies the drain voltage to the first stage of the 3-stage amplifier IC. Apply gate voltage to VG pins before applying drain voltage.	
VD3	Drain Supply Voltage	Pad VD3 supplies the drain voltage to the first stage of the 3-stage amplifier IC. Apply gate voltage to VG pins before applying drain voltage.	
VG1	Gate Supply Voltage	VG1 provides gate bias to the first stage of the 3-stage amplifier. The user should apply between -0.4 and -0.6V to VG1 pad before applying any VD drain supply.	
VG2	Gate Supply Voltage	VG2 provides gate bias to the first stage of the 3-stage amplifier. The user should apply between -0.4 and -0.6V to VG2 pad before applying any VD drain supply.	
VG3	Gate Supply Voltage	VG3 provides gate bias to the first stage of the 3-stage amplifier. The user should apply between -0.4 and -0.6V to VG3 pad before applying any VD drain supply.	

Specifications

Absolute Maximum Ratings

The Absolute Maximum Ratings indicate limits beyond which damage may occur to the device. If these limits are exceeded, the device may become inoperable or have a reduced lifetime. This amplifier is designed and characterized in a 50Ω system, and operation in a reflective environment can cause performance degradation.

Parameter	Maximum Rating	Unit
Continuous Power Dissipation (PDISS) (at 85 °C case temp.) ¹	1	W
Maximum Operating Temperature	85	°C
Maximum Storage Temperature	150	°C
Max Junction Temperature for MTTF > 1E6 Hours	175	°C
Minimum Operating Temperature	-40	°C
Minimum Storage Temperature	-65	°C
Negative Bias Voltage (Vg)	-2	V
Positive Drain Supply Current (Id) (with RF Input)	450	mA
Positive Drain Supply Voltage (Vd)	4.5	V
RF Input Power	20	dBm
Thermal Resistance, θJC	90	°C/W

^[1] Derates by 11 mW/ °C above 85 °C case temperature.

FIT and MTTF Table

T (°C)	λ (TIF)	MTTF (hr)	MTTF (yr)
105	2,441.45	4.10E+05	47
85	310.48	3.22E+06	368
55	8.79	1.14E+08	12,992
25	0.12	8.24E+09	941,063

Package Information

Parameter	Details	Rating
Dimensions	-	1.38 x 1.25 mm

Recommended Operating Conditions

The Recommended Operating Conditions indicate the limits, inside which the device should be operated, to guarantee the performance given in Electrical Specifications. Operating outside these limits may not necessarily cause damage to the device, but the performance may degrade outside the limits of the electrical specifications. For limits, above which damage may occur, see Absolute Maximum Ratings. Power Supply DC current should be modified by changing bias voltage Vg to maintain junction temperature within MTTF target for given operating conditions.

Parameter	Min	Nominal	Max	Unit
Ambient Temperature	-40	25	85	°C
Input Power for Saturation	6	9	12	dBm
Negative Bias Voltage (Vg)	-0.6	-0.5	-0.4	V
Power Supply DC Voltage (Vd)	2.5	3	3	V
Power Supply DC Current (Id) (No RF Input)	100	150	210	mA

Sequencing Requirements

Turn-on Procedure:

1. Apply negative bias voltage to Vg pads
2. Apply positive supply voltage to Vd pads

Turn-off Procedure:

1. Turn off Vd supply
2. Turn off Vg bias

Note: RF input power can be injected at any moment in the bias sequencing procedure.

Electrical Specifications

The electrical specifications apply at TA=+25°C in a 50Ω system. Min and Max limits apply only to our connectorized units and are guaranteed at TA=+25°C. Die are 100% DC tested and RF tested on a per lot basis

Parameter	Test Conditions	Minimum Frequency (GHz)	Maximum Frequency (GHz)	Min	Typ	Max	Unit
Current Consumption ¹	3V/-0.4V	-	-	-	200	-	mA
Current Consumption ²	3V/-0.5V	-	-	-	150	-	mA
Current Consumption ³	3V/-0.6V	-	-	-	100	-	mA
Input IP3	3V/-0.5V, -20 dBm Input Power	12	46	-	12	-	dBm
Input Power for Saturation	3V/-0.5V bias	12	46	-	9	-	dBm
Input Return Loss	3V/-0.5V Bias	12	46	-	19	-	dB
Noise Figure	3V/-0.5V bias	12	46	-	5.9	-	dB
Output IP3	3V/-0.5V, -20 dBm Input Power	12	46	-	29	-	dBm
Output P1dB	3V/-0.5V bias	12	46	-	19	-	dBm
Output Return Loss	3V/-0.5V Bias	12	46	-	18	-	dB
Reverse Isolation	3V/-0.5V Bias	12	46	-	60	-	dB
Saturated Output Power ⁴	3V/-0.5V bias	18	35	17	20.5	-	dBm
Saturated Output Power ⁵	3V/-0.5V bias	12	18	-	18	-	dBm
Saturated Output Power ⁶	3V/-0.5V bias	35	46	-	18.5	-	dBm
Small Signal Gain	3V/-0.5V bias	18	35	14	18	-	dB
Small Signal Gain	3V/-0.5V bias	12	18	-	17	-	dB
Small Signal Gain	3V/-0.5V bias	35	46	-	15	-	dB

[1][2][3] Bias conditions tested with no RF input power. Bias conditions presented as Vd/Vg.

[4][5][6] Saturated Output Power specification defined using the AMM-7200UC.

Typical Performance Plots

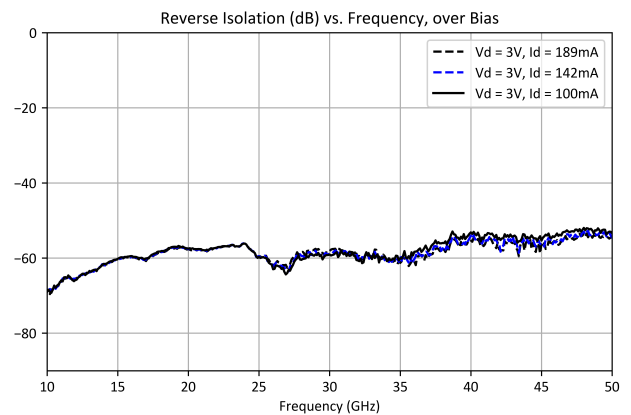
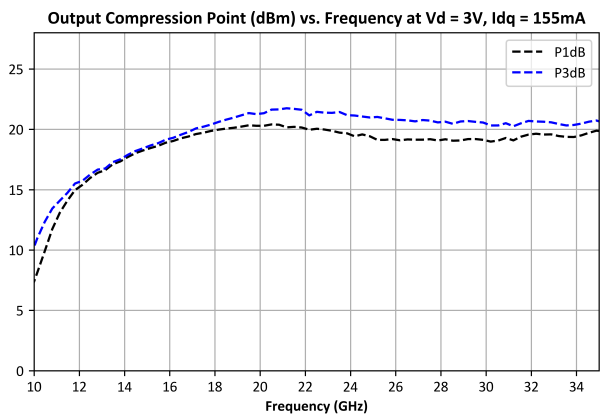
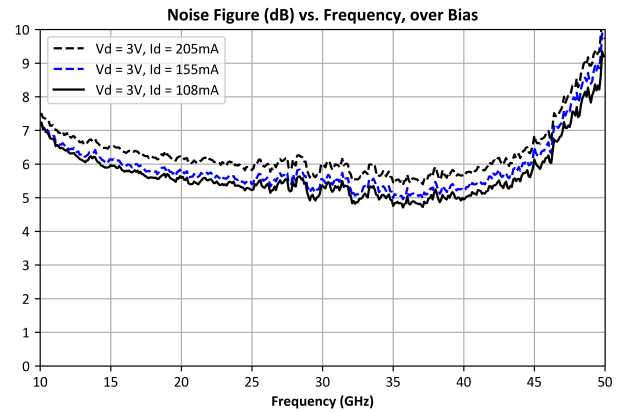
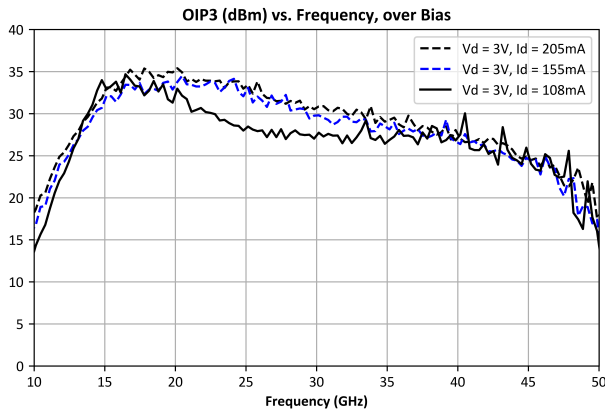
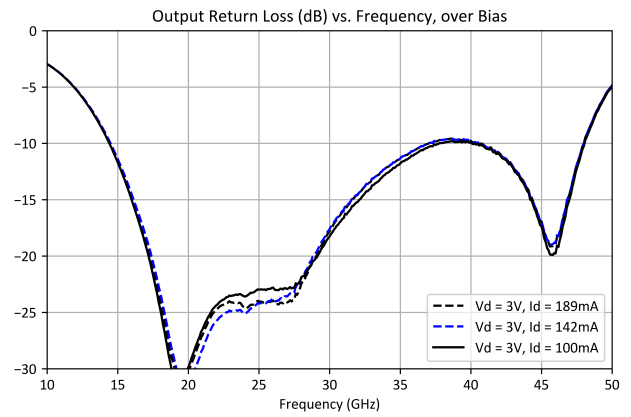
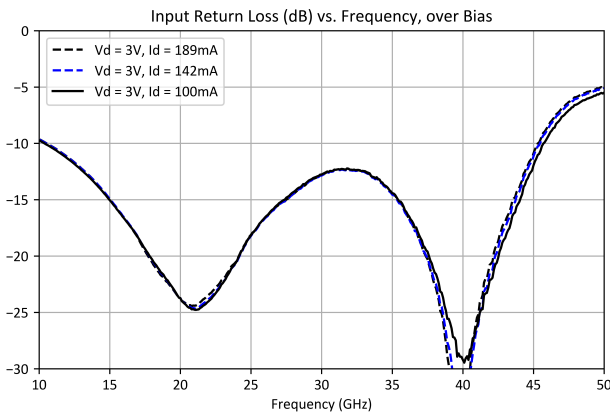
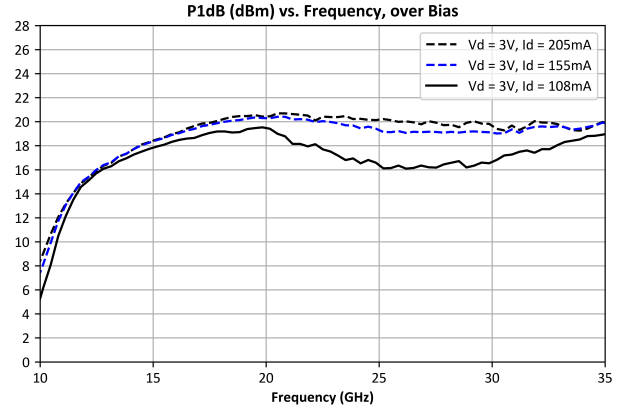
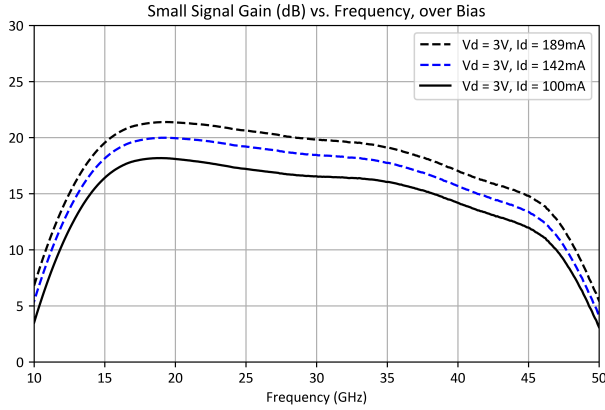

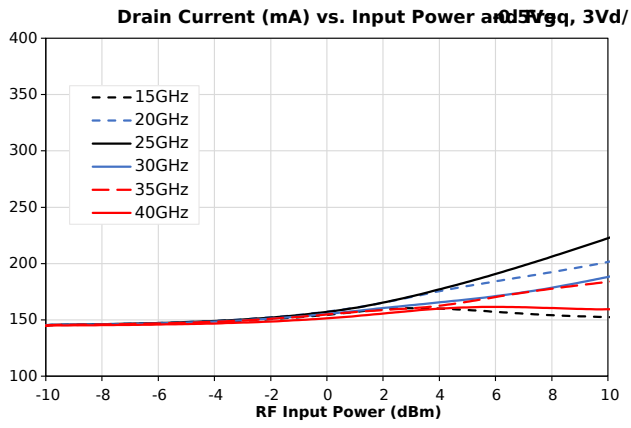

Application Information

Below are the recommended application circuits for the AMM-7200ACH. This application circuit is used for the performance plots shown in this datasheet. However, each PCB layout and environment are different which may require minor modifications of the biasing network.

Application Circuit

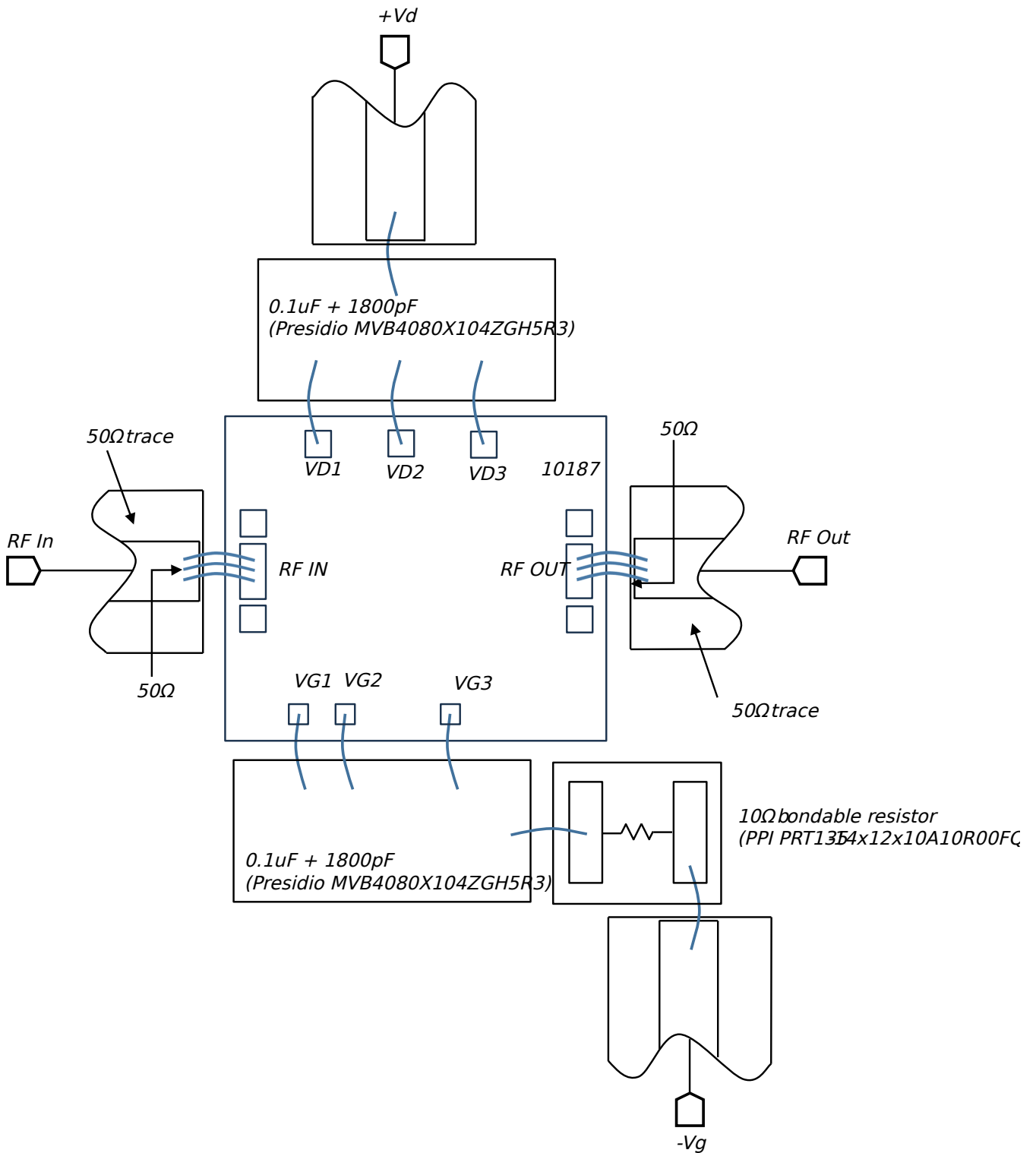

Application Circuit Description

Constant Drain Current vs. Constant Gate Voltage Operation

The AMM-7200 pHEMT amplifier can be biased with a constant gate and drain voltage, or with a constant drain current by regulating the gate voltage. Using a constant gate and drain voltage reduces circuit complexity, but has variable current consumption during operation. However, regulating the gate voltage using feedback circuitry which controls the drain current to a constant value minimizes unit-to-unit variation in gain, output power, and compression points.

Under small signal excitation at a fixed temperature, these two approaches are equivalent because the current draw versus frequency is relatively constant in small signal. However, they will diverge in large signal conditions, where the drain current is affected the input signal's frequency and power. The output power in saturation is relatively unchanged, as it is more strongly dependent on the drain voltage. However, output referred 1dB compression point will decrease by 2-3dB when operated with a constant drain current.

Mechanical Data

Outline Drawing

Download : [Outline 2D Drawing](#)

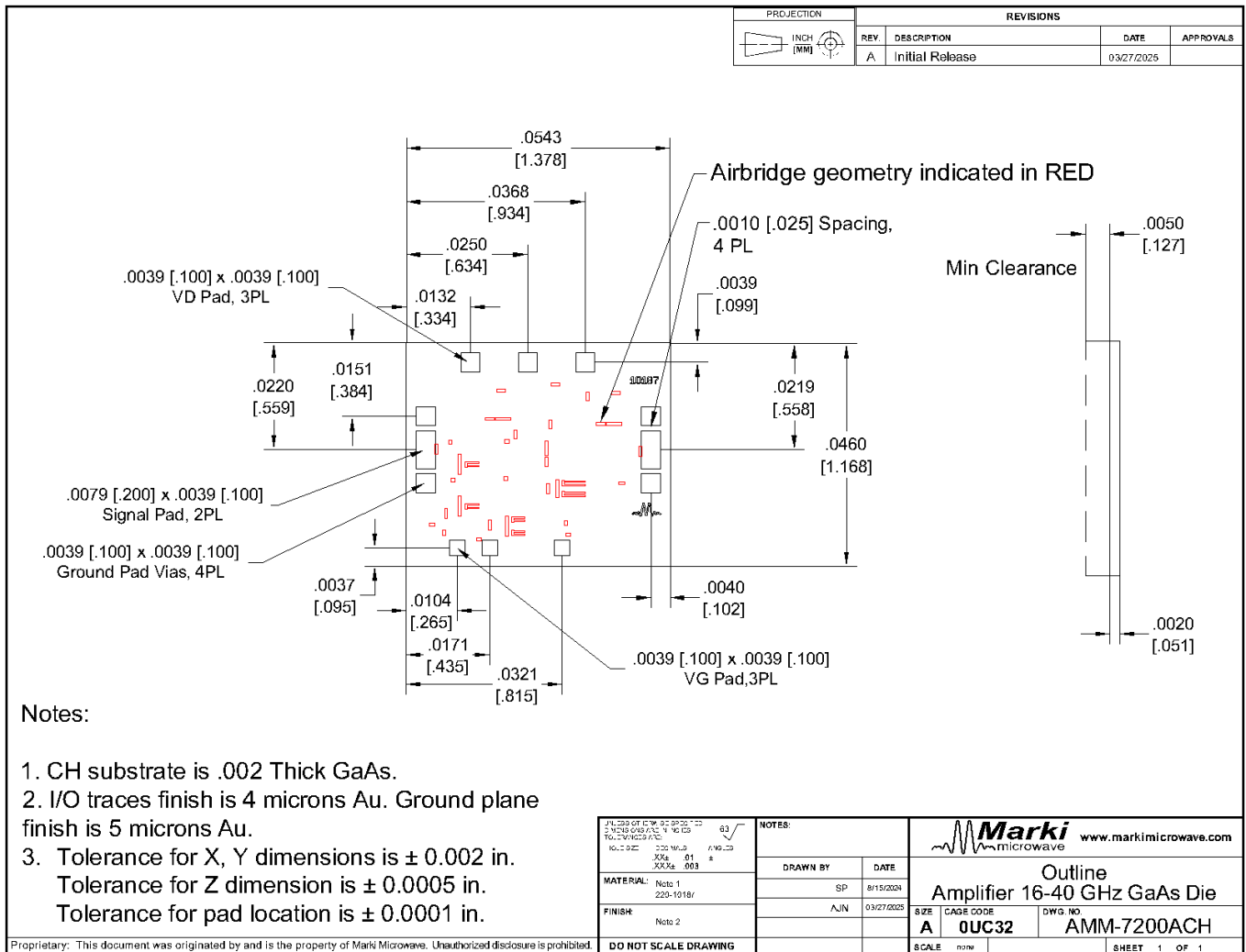

Notes:

- CH substrate is .002 Thick GaAs.
- I/O traces finish is 4 microns Au. Ground plane finish is 5 microns Au.
- Tolerance for X, Y dimensions is ± 0.002 in.
 Tolerance for Z dimension is ± 0.0005 in.
 Tolerance for pad location is ± 0.0001 in.

DISCLAIMER

MARKI MICROWAVE, LLC., (“MARKI”) PROVIDES TECHNICAL SPECIFICATIONS AND DATA (INCLUDING DATASHEETS), APPLICATION OR OTHER DESIGN ADVICE, WEB TOOLS, AND OTHER INFORMATION AND RESOURCES “AS IS” AND WITH ALL FAULTS. MARKI DISCLAIMS ALL WARRANTIES, EXPRESS OR IMPLIED, INCLUDING, WITHOUT LIMITATION, ANY IMPLIED WARRANTIES OF MERCHANTABILITY, FITNESS FOR A PARTICULAR PURPOSE, OR NON-INFRINGEMENT.

These resources are intended for developers skilled in the art designing with Marki products. You are solely responsible for (1) selecting the appropriate products for your application, (2) designing, validating, and testing your application, and (3) ensuring your application meets applicable standards and other requirements. Marki makes no guarantee regarding the suitability of its products for any particular purpose, nor does Marki assume any liability whatsoever arising out of your use or application of any Marki product.

Marki grants you permission to use these resources only for development of an application that uses Marki products. Other reproduction or use of these resources is strictly prohibited. No license is granted to any other Marki intellectual property or to any third-party intellectual property. Marki reserves the right to make changes to the product(s) or information contained herein without notice.

MARKI MICROWAVE and T3 MIXER are trademarks or registered trademarks of Marki Microwave, LLC. All other trademarks used are the property of their respective owners.

© 2024 - 2026, Marki Microwave, LLC