

APM-6849PA

GaAs Broadband Low Phase Noise Amplifier

DEVICE OVERVIEW

General Description

The APM-6849 is a single stage broadband, low phase noise LO driver amplifier designed to provide saturated +21 dBm output power. This amplifier uses GaAs HBT technology for low phase noise, and provides industry leading -170 dBc/Hz at 10 kHz offset from carrier frequency. The amplifier is also highly efficient with 21% peak PAE at 5 GHz input frequency and low DC current draw. It is optimized to provide enough power to drive the LO port of an S-diode mixer (2 – 20 GHz) and an H/L-diode mixer (2 - 32 GHz). This amplifier is operational with a variety of bias conditions for both low and high-power applications.

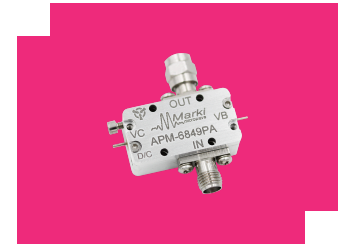

Features

- -170 dBc/Hz phase noise at 10kHz offset frequency
- +21 dBm output power
- Low DC power consumption
- Positive-only biasing
- No sequencing required
- Unconditionally stable
- Integrated DC blocks – No bias-tees or off-chip blocking required

Applications

- Mobile test and measurement equipment
- Radar and satellite communications
- 5G transceivers
- Driver amplifier L,H,S – diode mixers
- Suitable as a T3 drive

Functional Block Diagram

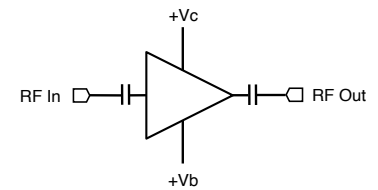

Part Ordering Options

Part Number	Description	Package	Connectors	Green Status	Product Lifecycle	Export Classification
APM-6849PA	GaAs Broadband Low Phase Noise Amplifier	PA	<u>Standard</u>	REACH RoHS	Released	EAR99

Table Of Contents

- **Device Overview**
 - General Description
 - Features
 - Applications
 - Functional Block Diagram
- **Port Configuration and Functions**
 - Port Diagram
 - Port Functions
- **Revision History**
- **Specifications**
 - Absolute Maximum Ratings
 - Package Information
 - Recommended Operating Conditions
 - Sequencing Requirements
 - Electrical Specifications
 - Typical Performance Plots
 - Typical Performance Plots of Marki Mixers Driven with APM-6849PA
- **Mechanical Data**
 - Outline Drawing

Revision History

Revision Code	Revision Date	Comment
-	2019-11-01	Datasheet Initial Release
A	2020-01-01	Added Time Domain Plots
B	2020-07-01	Updated Max Operating Temperature
C	2020-07-01	Updated Thermal Resistance Specification
D	2020-10-01	Updated Thermal Specs, Updated Min Specs
E	2023-02-01	Added IP2 Plots

Port Configuration and Functions

Port Diagram

A port diagram of the APM-6849PA is shown below.

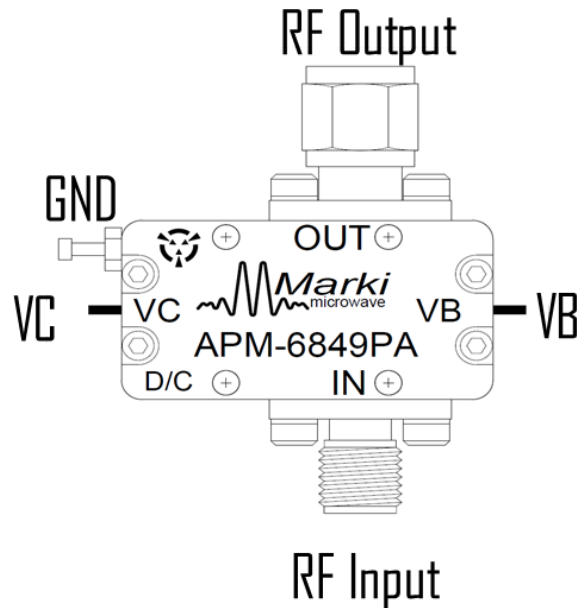

Port Functions

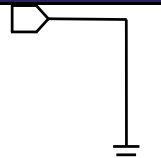
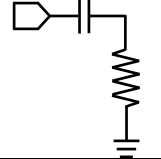
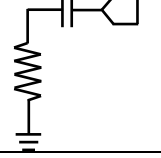
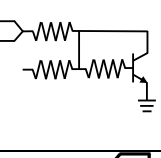
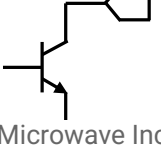
Port	Function	Connector Type	Description	Equivalent Circuit for Package
GND	Ground	-	Housing or coaxial cable's outer metal layer must be connected to a DC/RF ground potential with high thermal and electrical conductivity.	
RF In	RF Input	2.92F	This is the RF input port of the amplifier. It is internally DC blocked and RF matched to 50 Ω.	
RF Out	RF Output	2.92M	This is the amplifier RF output port. It is internally DC blocked and RF matched to 50 Ω. Must have less than 7:1 VSWR when operating with voltage greater than +5V on port VC.	
VB	Base Supply	-	Port VB is the current mirror DC voltage supply port that controls the collector current supplied to the amplifier. VB port voltage is proportional to VC port collector current. VB effectively functions as a gain control pin. The VB port in the PA module internally connects to the IC's VB port.	
VC	Collector Supply	-	Port VC is the 1-stage amplifier DC voltage supply port. The PA module VC port connects internally to the IC's VC port.	

Specifications

Absolute Maximum Ratings

The Absolute Maximum Ratings indicate limits beyond which damage may occur to the device. If these limits are exceeded, the device may become inoperable or have a reduced lifetime.

Parameter	Maximum Rating	Unit
Collector Positive Bias Voltage (Vc)	7	V
Current Mirror Positive Bias Current (Ib)	4	mA
Current Mirror Positive Bias Voltage (VB)	7	V
Maximum Operating Temperature	85	°C
Maximum Storage Temperature	150	°C
Max Junction Temperature for MTTF > 1E6 Hours	125	°C
Minimum Operating Temperature	-40	°C
Minimum Storage Temperature	-65	°C
Positive Bias Current (Ic)	90	mA
RF Input Power	16	dBm
Thermal Resistance, θ_{JC}	78	°C/W

Package Information

Parameter	Details	Rating
Weight	Package name: PA	14.7g
Dimensions	-	28.45 x 14.99 mm

Recommended Operating Conditions

The Recommended Operating Conditions indicate the limits, inside which the device should be operated, to guarantee the performance given in Electrical Specifications. Operating outside these limits may not necessarily cause damage to the device, but the performance may degrade outside the limits of the electrical specifications. For limits, above which damage may occur, see Absolute Maximum Ratings.

Parameter	Min	Nominal	Max	Unit
Ambient Temperature	-40	25	85	°C
Positive DC Voltage (VC)	3	5	6	V
Positive DC Current (Ic) ¹	8	21	32	mA
Positive DC Current Mirror Voltage (VB)	3	5	6	V
Positive DC Current Mirror Current (Ib)	0.9	2	2.6	mA

^[1] Recommended operating current condition without RF input applied. Please see performance plots for relationship between RF input power and DC current.

Sequencing Requirements

There is no sequencing required to power up or power down the amplifier.

Amplifier must have an output load connected when operating with a VC voltage greater than +5V.

Electrical Specifications

The electrical specifications apply at TA=+25°C in a 50Ω system. Min and Max limits apply only to our connectorized units and are guaranteed at TA=+25°C. Die are 100% DC tested and RF tested on a per lot basis.

Parameter	Test Conditions	Minimum Frequency (GHz)	Maximum Frequency (GHz)	Min	Typ	Max	Unit
Collector Current, Ic ¹	5V/4V	-	-	-	13	-	mA
Collector Current, Ic ²	5V/5V	-	-	-	21	-	mA
Collector Current, Ic ³	5V/6V	-	-	-	32	-	mA
Current Mirror Current, Ib	5V/4V	-	-	-	1.5	-	mA
Current Mirror Current, Ib	5V/5V	-	-	-	2	-	mA
Current Mirror Current, Ib	5V/6V	-	-	-	2.6	-	mA
Input IP3	5V/5V bias, -15 dBm Input Power	2	29	-	10	-	dBm
Input Power for Saturation	5V/5V bias	2	29	-	10	-	dBm
Input Return Loss	5V/5V bias, -25 dBm Input Power	20	29	-	8	-	dB
Input Return Loss	5V/5V bias, -25 dBm Input Power	2	20	-	15	-	dB
Noise Figure	5V/5V bias, -25 dBm Input Power	2	26.5	-	5	-	dB
Output IP3	5V/5V bias, -15 dBm Input Power	2	29	-	21	-	dBm
Output P1dB	5V/5V bias	20	29	-	15	-	dBm
Output P1dB	5V/5V bias	2	20	-	20	-	dBm
Output Power ⁴	5V/5V Bias, Input Driver (See footnote)	2	20	19	21	-	dBm
Output Power ⁵	5V/5V Bias, Input Driver (See footnote)	20	29	-	19	-	dBm
Output Return Loss	5V/5V bias, -25 dBm Input Power	20	29	-	11	-	dB
Output Return Loss	5V/5V bias, -25 dBm Input Power	2	20	-	15	-	dB
Phase Noise @10kHz Offset	5V/5V bias, +9 dBm Input power	2	29	-	-170	-	dBc/Hz
Reverse Isolation	5V/5V bias, -25 dBm Input Power	2	29	-	41	-	dB
Small Signal Gain	5V/5V bias, -25 dBm Input Power	2	20	9	11	-	dB
Small Signal Gain	5V/5V bias, -25 dBm Input Power	20	29	-	10	-	dB

[1] Bias conditions for Ic and Ib tested with no RF input power. See performance plots for DC current vs. RF power. Bias conditions presented as VC/VB.

[2][3] Bias conditions for Ic and Ib tested with no RF input power. See performance plots for DC current vs. RF power. Bias conditions presented as VC/VB.

[4][5] Saturated Output Power tested with two APM-6849PA connected in series; +6 dBm RF input power, corresponding to ~+16 dBm into DUT.

Typical Performance Plots

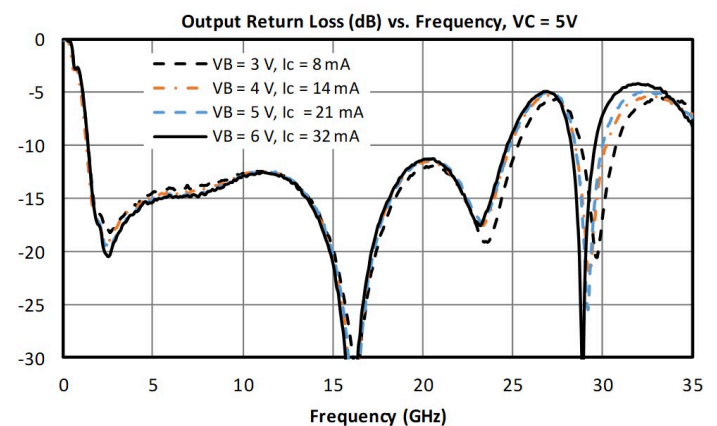
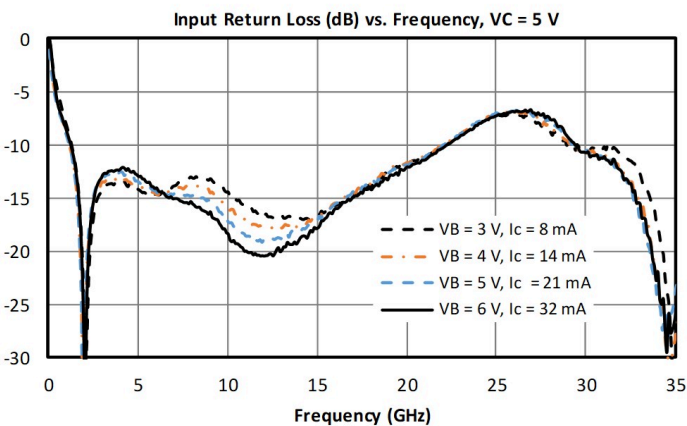
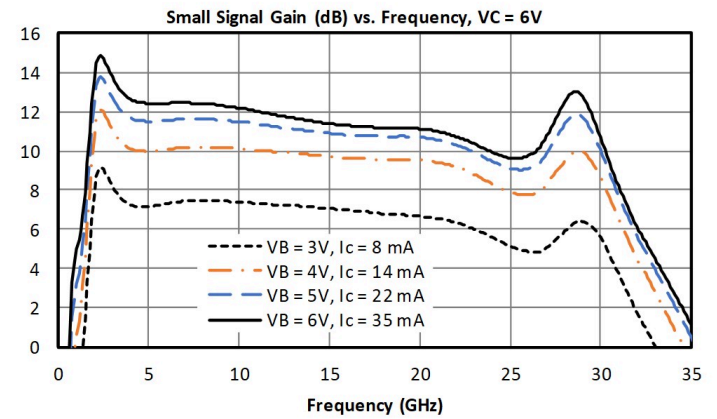
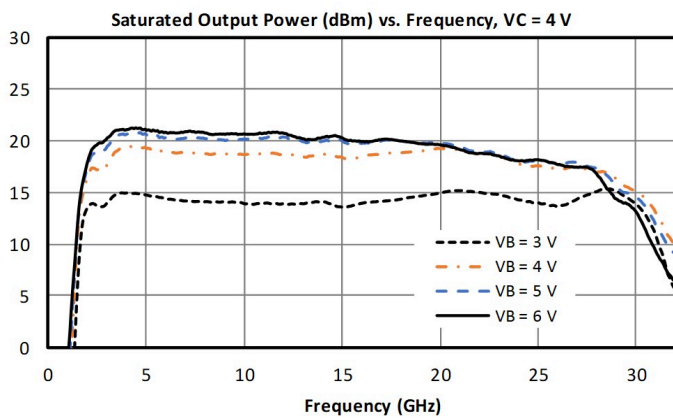
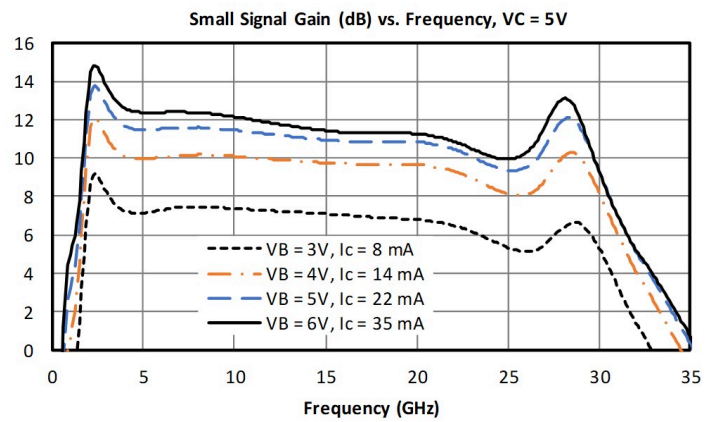
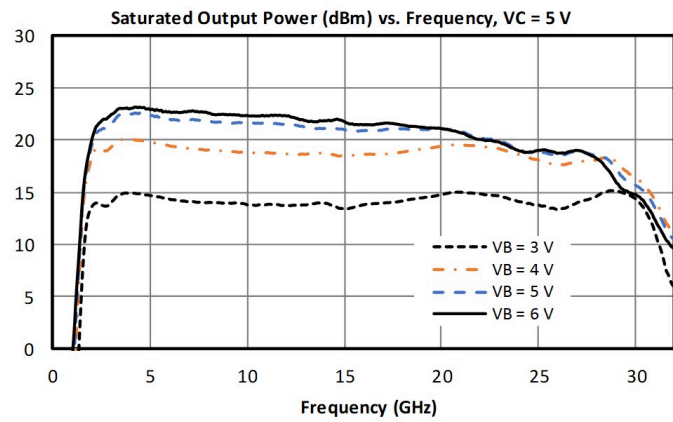
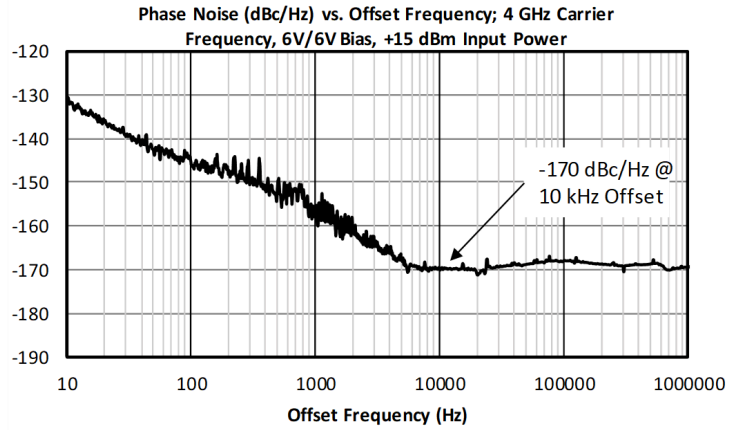
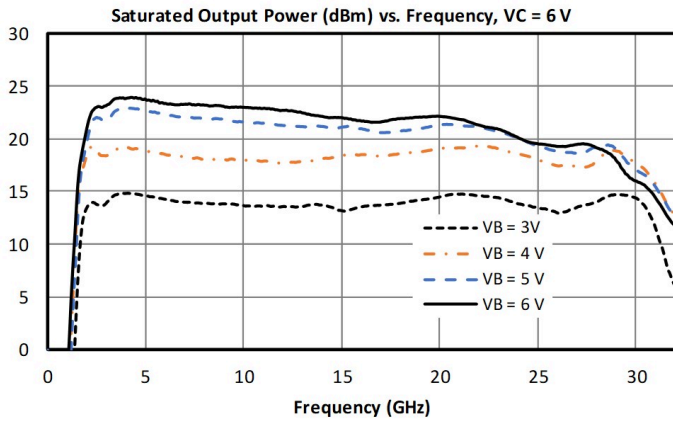

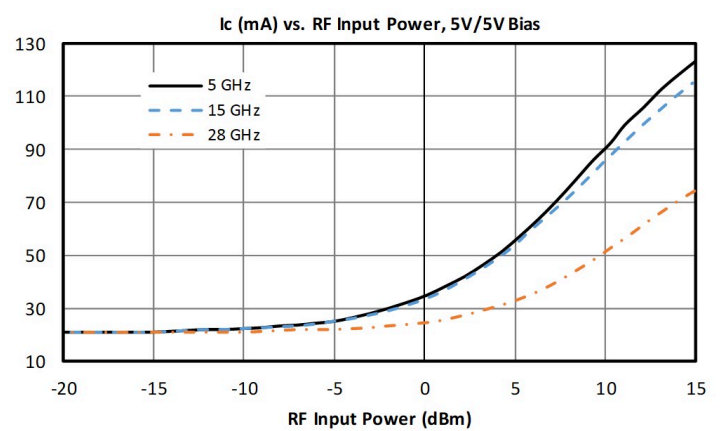
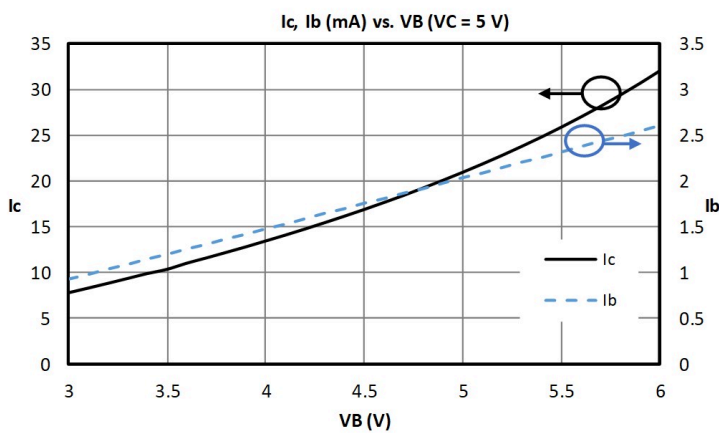
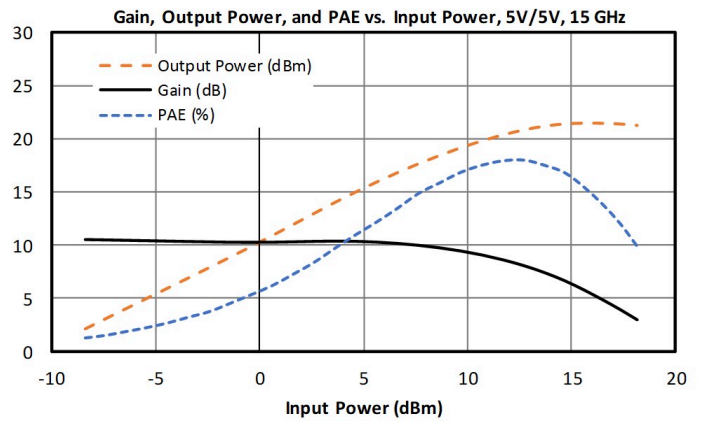
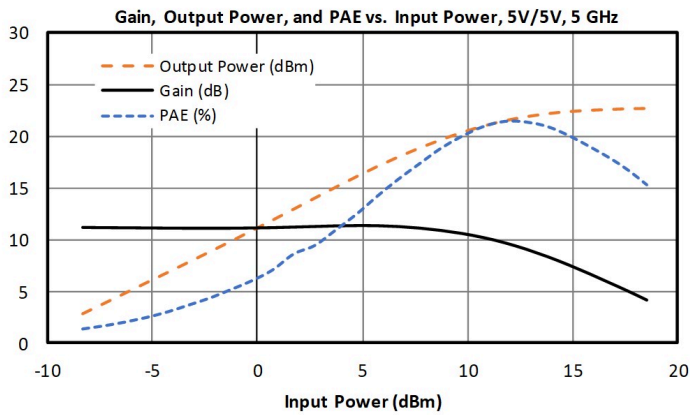
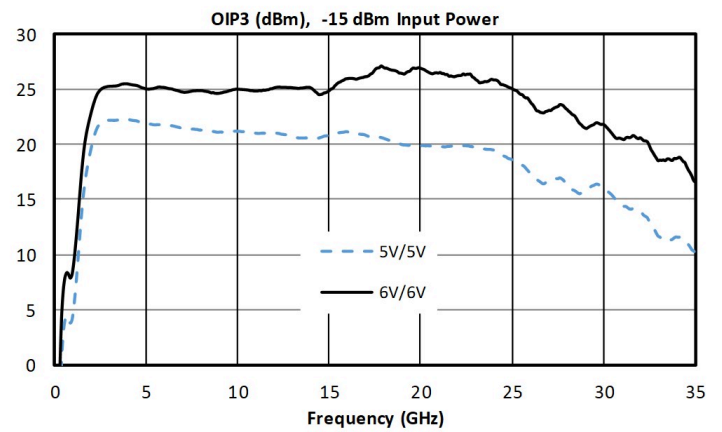
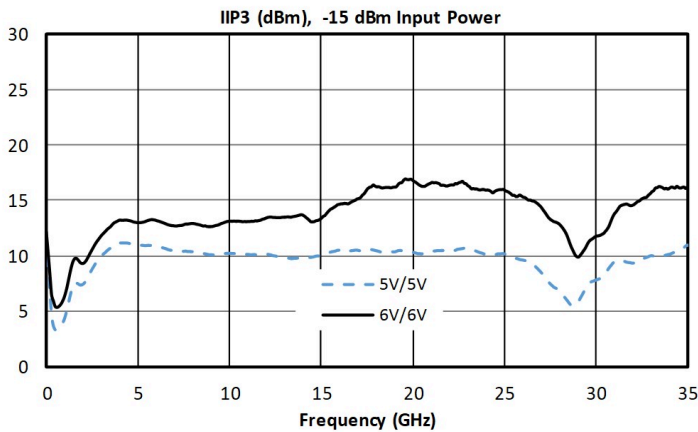
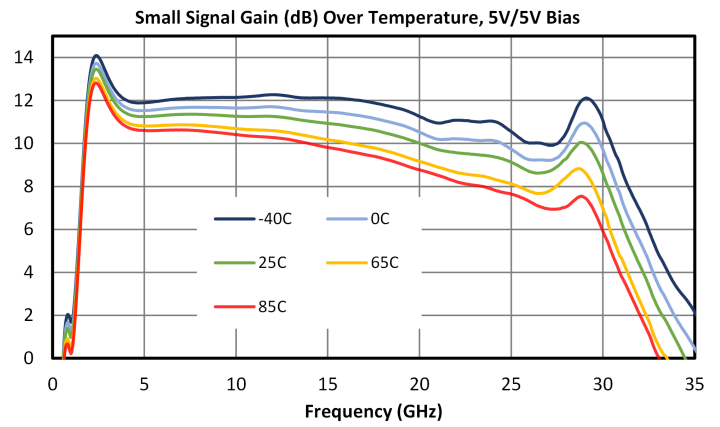
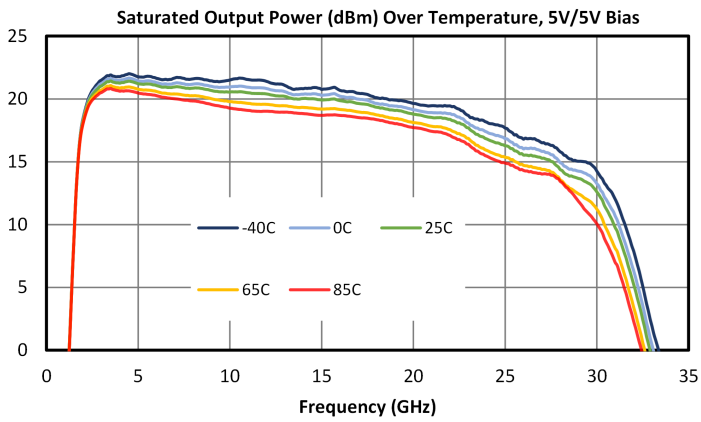

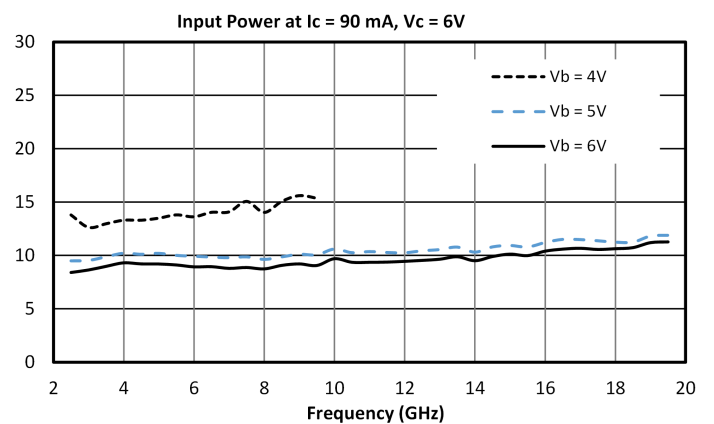
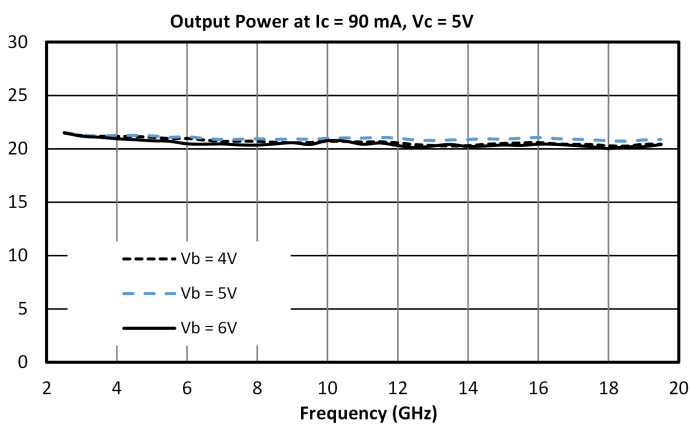
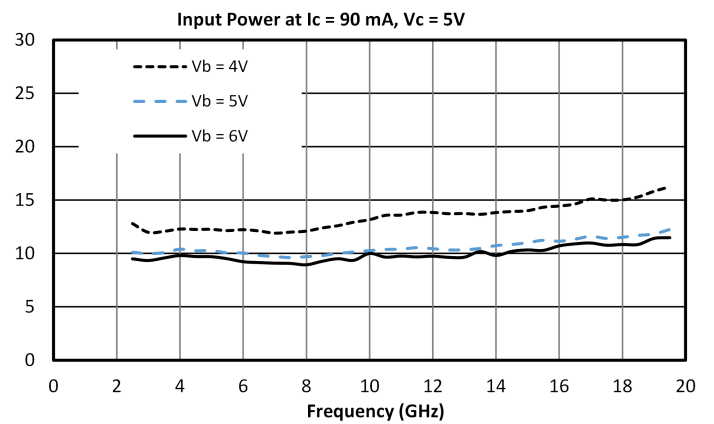
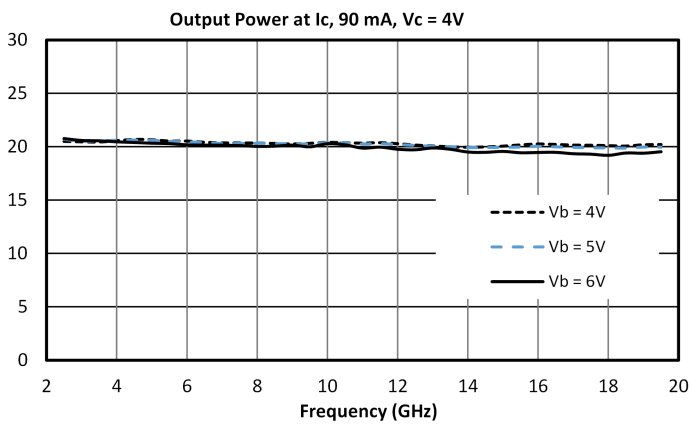
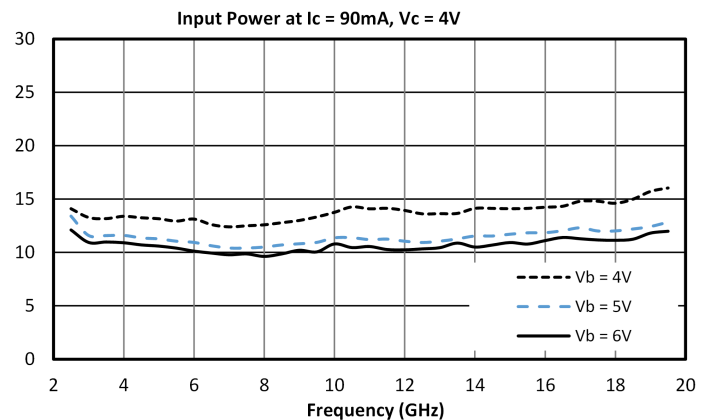
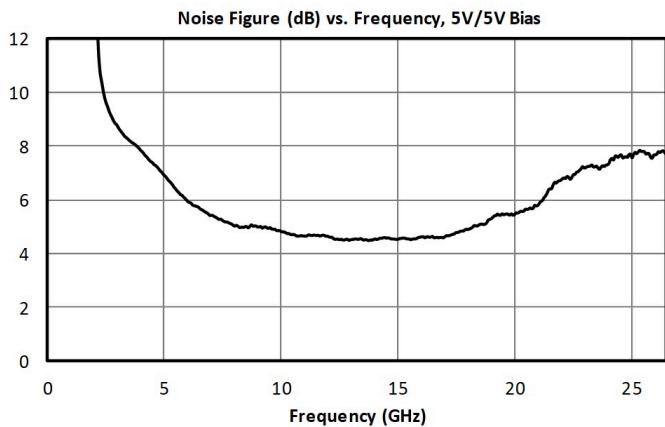
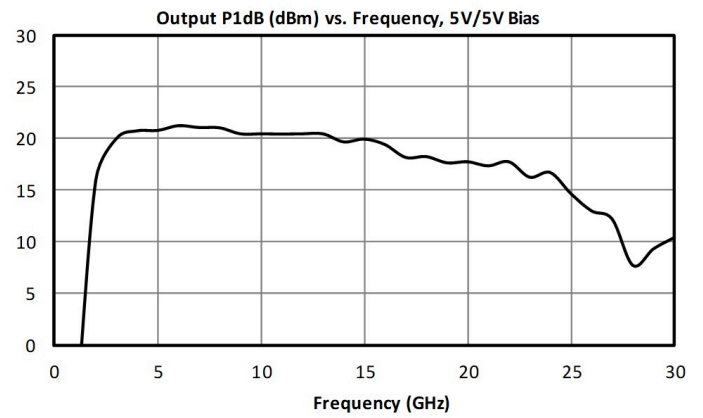
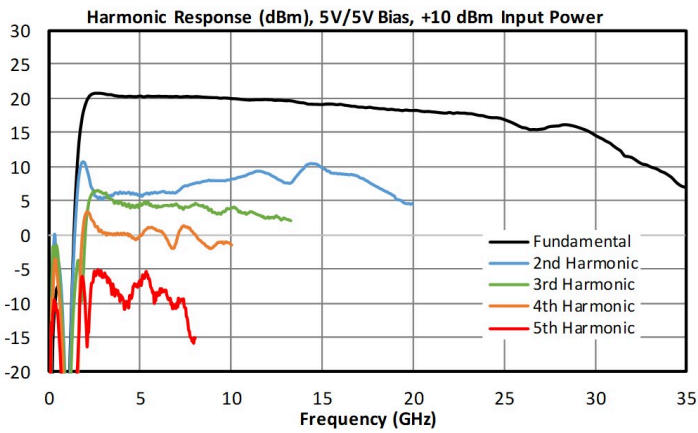

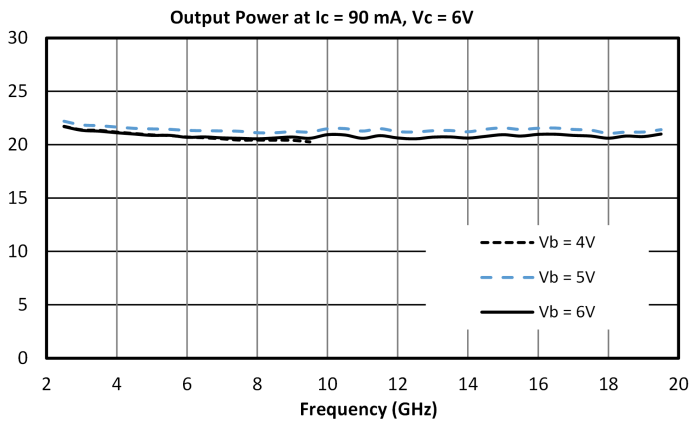

Typical Performance Plots of Marki Mixers Driven with APM-6849PA

Conv. Loss (dB) of Marki MM1-0212L (Config. A) using two APM-6849PA as LO Driver; 5V/5V Bias, +0 dBm Amp. Input; 100 MHz IF

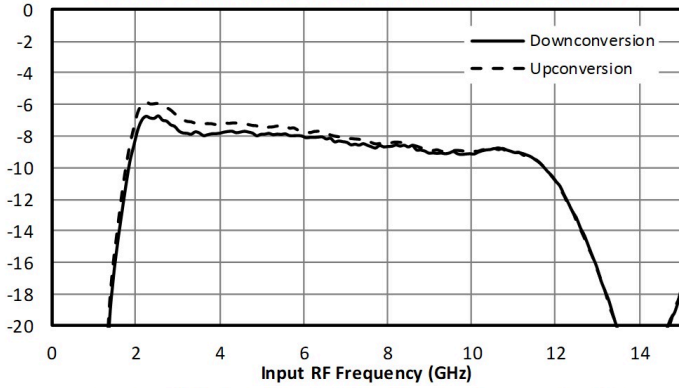

Conv. Loss (dB) of Marki MM1-0212S (Config. A); two series APM-6849PA as LO Driver; 5V/5V Bias, +0 dBm Amp. Input; 100 MHz IF

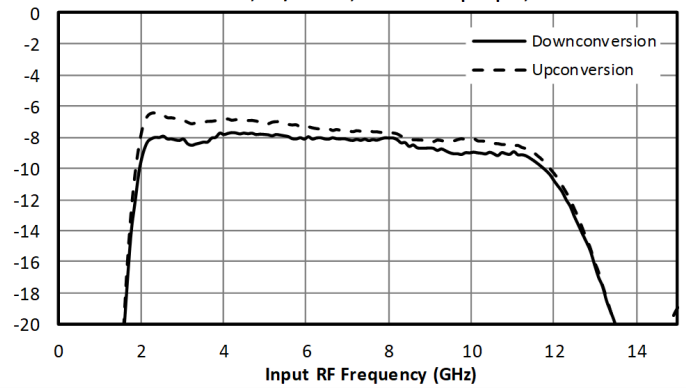

Conv. Loss (dB) of Marki MM1-0212H (Config. A); two series APM-6849PA as LO Driver; 5V/5V Bias, +0 dBm Amp. Input; 100 MHz IF

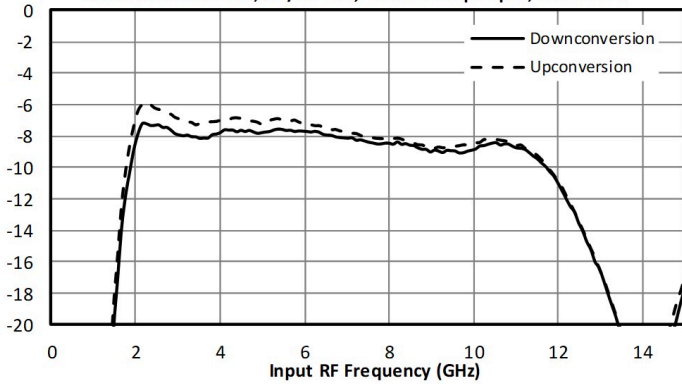

Conv. Loss (dB) of Marki MM1-1240S (Config. A); two series APM-6849PA as LO Driver; 5V/5V Bias, +6 dBm Amp. Input; 100 MHz IF

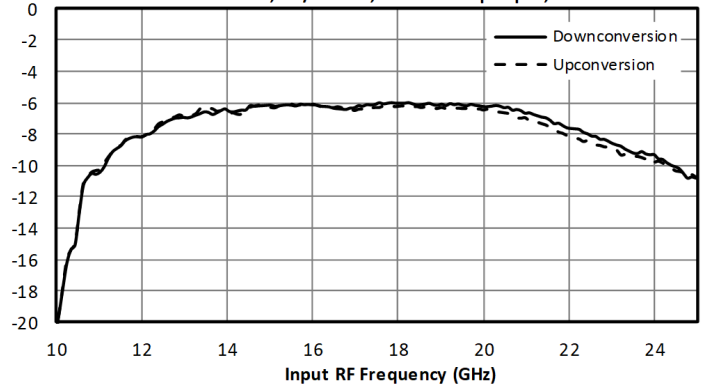

Conv. Loss (dB) of Marki MM1-0626S (Config. A); two series APM-6849PA as LO Driver; 5V/5V Bias, +6 dBm Amp. Input; 100 MHz IF

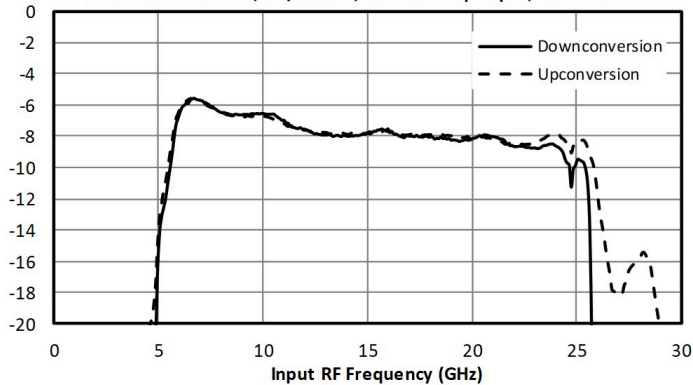

Conv. Loss (dB) of Marki MM1-0530L (Config. A) using two APM-6849PA as LO Driver; 5V/5V Bias, +0 dBm Amp. Input; 1 GHz IF

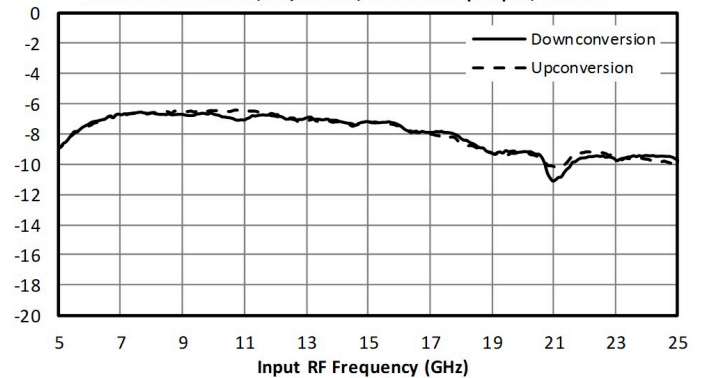

Mechanical Data

Outline Drawing

Download : [Outline 2D Drawing](#) | [Outline 3D Drawing](#) | [Outline 3D STP](#)

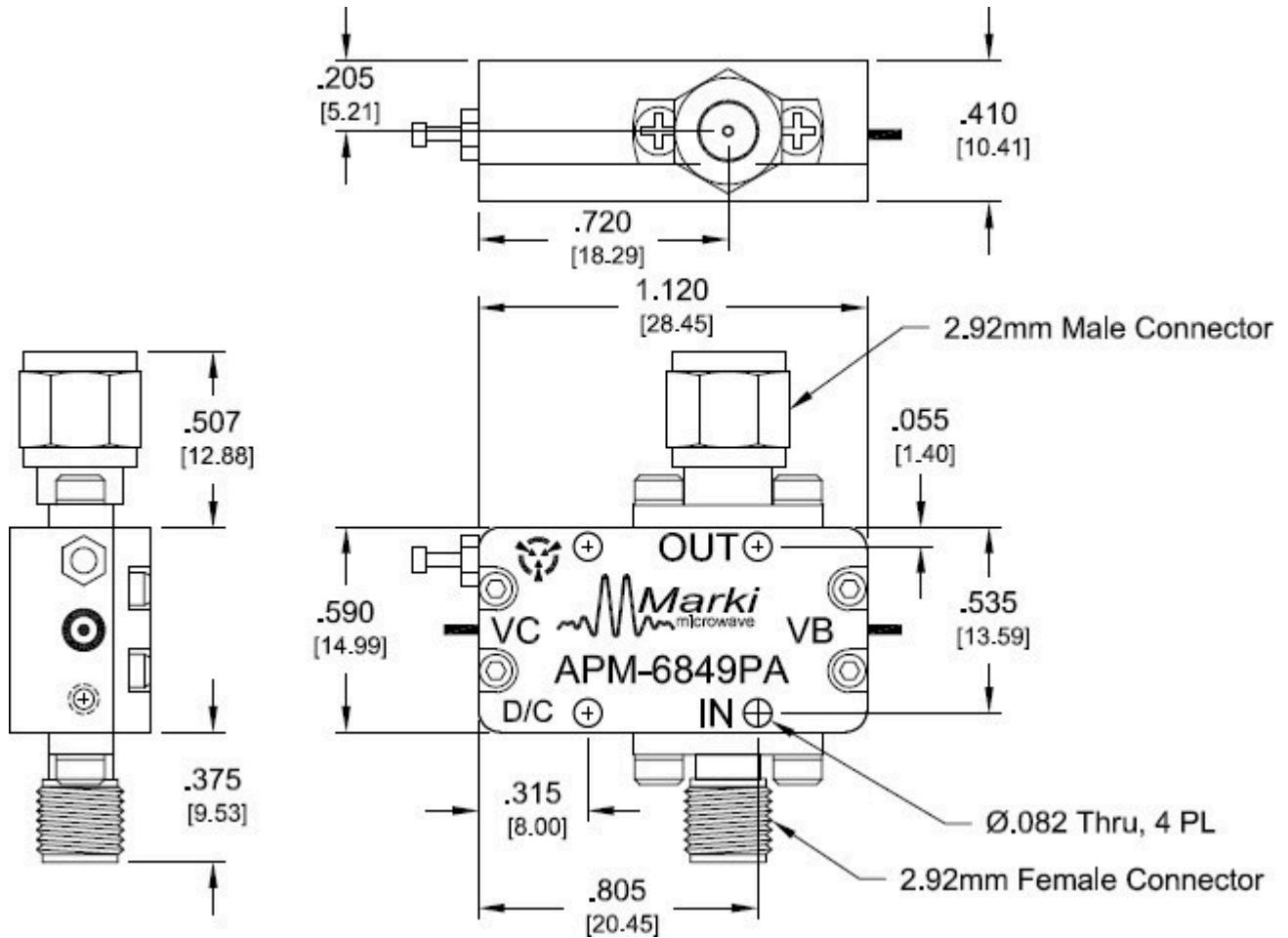

DISCLAIMER

MARKI MICROWAVE, INC., ("MARKI") PROVIDES TECHNICAL SPECIFICATIONS AND DATA (INCLUDING DATASHEETS), APPLICATION OR OTHER DESIGN ADVICE, WEB TOOLS, AND OTHER INFORMATION AND RESOURCES "AS IS" AND WITH ALL FAULTS. MARKI DISCLAIMS ALL WARRANTIES, EXPRESS OR IMPLIED, INCLUDING, WITHOUT LIMITATION, ANY IMPLIED WARRANTIES OF MERCHANTABILITY, FITNESS FOR A PARTICULAR PURPOSE, OR NON-INFRINGEMENT. These resources are intended for developers skilled in the art designing with Marki products. You are solely responsible for (1) selecting the appropriate products for your application, (2) designing, validating, and testing your application, and (3) ensuring your application meets applicable standards and other requirements. Marki makes no guarantee regarding the suitability of its products for any particular purpose, nor does Marki assume any liability whatsoever arising out of your use or application of any Marki product.

Marki grants you permission to use these resources only for development of an application that uses Marki products. Other reproduction or use of these resources is strictly prohibited. No license is granted to any other Marki intellectual property or to any third-party intellectual property. Marki reserves the right to make changes to the product(s) or information contained herein without notice.

MARKI MICROWAVE and T3 MIXER are trademarks or registered trademarks of Marki Microwave, Inc. All other trademarks used are the property of their respective owners.

© 2019 - 2020, 2023, Marki Microwave, Inc