

# APM-7099PA

## 0.01GHz – 20 GHz Low Phase Noise Amplifier

### DEVICE OVERVIEW

#### General Description

The APM-7099 is a broadband distributed, low phase noise driver amplifier designed to provide a saturated +25 dBm output power with low DC power consumption. This amplifier uses GaAs HBT technology for low phase noise, and is optimized to drive our NLTL multiplier line. It can also provides sufficient power to drive the LO port of an S-diode mixer from 10 MHz to 15 GHz or of an H or L diode mixer from 10 MHz to 20 GHz. This amplifier can be operated with a variety of bias conditions for both low power and high-power applications.



#### Features

- -167 dBc/Hz phase noise at 10 kHz offset frequency
- +25 dBm output power
- Low DC power consumption
- Positive-only biasing
- No sequencing required
- Unconditionally stable

#### Applications

- Mobile test and measurement equipment
- Radar
- SATCOM
- 5G transceivers
- Driver amplifier L,H,S – diode mixers
- Suitable as a T3 drive
- NLTL Driver

#### Functional Block Diagram

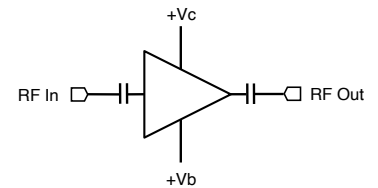

#### Part Ordering Options

Part Number	Description	Package	Connectors	Green Status	Product Lifecycle	Export Classification
APM-7099PA	0.01GHz – 20 GHz Low Phase Noise Amplifier	PA	<u>Standard</u>	REACH RoHS	Released	EAR99

**Table Of Contents**

- **Device Overview**
  - General Description
  - Features
  - Applications
  - Functional Block Diagram
- **Port Configuration and Functions**
  - Port Diagram
  - Port Functions
- **Revision History**
- **Specifications**
  - Absolute Maximum Ratings
  - Package Information
  - Recommended Operating Conditions
  - Sequencing Requirements
  - Electrical Specifications
  - Typical Performance Plots
  - Typical Performance Plots of Marki MT3H-0113H with APM 7099PA LO Driver
  - Time Domain Plots
- **Mechanical Data**
  - Outline Drawing
- **Notes**

**Revision History**

Revision Code	Revision Date	Comment
-	2020-10-01	Datasheet Initial Release
A	2021-03-01	Updated maximum input power and min specs
B	2021-06-01	Updated Saturated Output Power Min Spec Bandwidth
C	2021-08-01	Updated Thermal Resistance
D	2023-02-01	Updated IP2 Plots

## Port Configuration and Functions

### Port Diagram

A port diagram of the APM-7099PA is shown below.

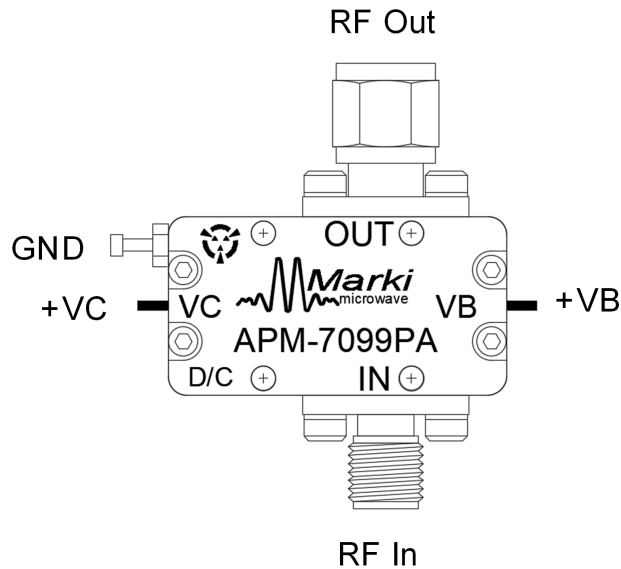

### Port Functions

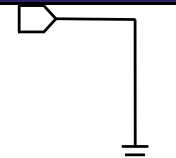
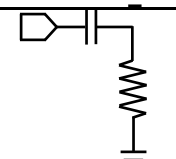
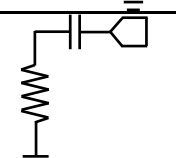
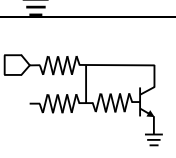
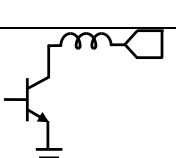
Port	Function	Connector Type	Description	Equivalent Circuit for Package
GND	Ground	-	Housing or outside of the coaxial cables must be connected to a DC/RF ground potential with high thermal and electrical conductivity.	
RF In	RF Input	2.92F	This is the RF Input port of the amplifier die. It is RF matched to 50 $\Omega$ , and has built-in DC blocking capacitors.	
RF Out	RF Output	2.92M	This is the amplifier's RF Output. It is RF matched to 50 $\Omega$ and has built-in DC blocking capacitors. Must have less than 7:1 VSWR when operating with voltage larger 8V on VC	
VB	Base Current Mirror Bias Port	-	Port VB is the DC voltage bias for the current mirror that controls collector current supplied to the amplifier. Larger voltages result in a higher current draw through port VC, effectively functioning as a gain control pin of the amplifier. See section 3.6 for performance at different bias conditions.	
VC	Collector DC Supply Port	-	Port VC is the DC voltage supply for that supplies the amplifier's collector current. It is connected internally through the amplifier die's RF output port.	

## Specifications

### Absolute Maximum Ratings

The Absolute Maximum Ratings indicate limits beyond which damage may occur to the device. If these limits are exceeded, the device may become inoperable or have a reduced lifetime.

Parameter	Maximum Rating	Unit
Collector Positive Bias Voltage (Vc)	9	V
Maximum Operating Temperature	85	°C
Maximum Storage Temperature	150	°C
Max Junction Temperature for MTTF > 1E6 Hours	125	°C
Max Power Dissipation for MTTF of 1E6 hours at 85°C Baseplate Temperature	709	mW
Minimum Operating Temperature	-40	°C
Minimum Storage Temperature	-65	°C
Output Load VSWR	7	-
Positive Bias Current (Ic)	225	mA
Positive DC Current Mirror Voltage (Vb)	9	V
RF Input Power (10 MHz – 3GHz)	12	dBm
RF Input Power (3 GHz – 20 GHz)	15	dBm
θJC, Junction to Ambient Thermal Resistance	38	°C/W

### Package Information

Parameter	Details	Rating
Weight	Package name: PA	15g
Dimensions	-	28.5 x 15 mm

### Recommended Operating Conditions

The Recommended Operating Conditions indicate the limits, inside which the device should be operated, to guarantee the performance given in Electrical Specifications. Operating outside these limits may not necessarily cause damage to the device, but the performance may degrade outside the limits of the electrical specifications. For limits, above which damage may occur, see Absolute Maximum Ratings. Module conditions provided for laboratory conditions. For use in test systems with extended lifetimes bare die operating conditions should be followed.

Parameter	Min	Nominal	Max	Unit
Power Supply DC Voltage (VC)	5	8	9	V
Bias Voltage (VB)	5	7	9	V
Power Supply DC Current (Ic) (No RF Input) <sup>1</sup>	38	72	132	mA
Input Power for Saturation	10	11	12	dBm
Power Supply DC Current (with RF Input) <sup>2</sup>	-	-	225	mA
Ambient Temperature	-40	25	40	°C

<sup>[1]</sup> Ic should be modified by changing bias voltage VB to maintain junction temperature within MTTF target for given operating conditions. Recommended operating current conditions without RF input applied. Please see typical performance plots for relationship between RF input power and DC current draw.

<sup>[2]</sup> Operation above recommended max power supply DC current will result in reduced MTTF.

### Sequencing Requirements

There is no sequencing required to power up or power down the amplifier. Amplifier must have an output load connected during operation.

**Electrical Specifications**

The electrical specifications apply at TA=+25°C in a 50Ω system. Min and Max limits apply only to our connectorized units and are guaranteed at TA=+25°C. Die are 100% DC tested and RF tested on a per lot basis

Parameter	Test Conditions	Minimum Frequency (GHz)	Maximum Frequency (GHz)	Min	Typ	Max	Unit
Collector Current, Ic <sup>1</sup>	8V/6V	-	-	-	53	-	mA
Collector Current, Ic <sup>2</sup>	8V/7V	-	-	-	72	-	mA
Collector Current, Ic <sup>3</sup>	8V/8V	-	-	-	96	-	mA
Current Mirror Current, Ib	8V/6V	-	-	-	3.4	-	mA
Current Mirror Current, Ib	8V/7V	-	-	-	4.2	-	mA
Current Mirror Current, Ib	8V/8V	-	-	-	5	-	mA
Input IP3	8V/7V bias, -15 dBm Input Power	0.01	20	-	12	-	dBm
Input Power for Saturation	8V/7V bias	0.01	20	-	12	-	dBm
Input Return Loss	8V/7V bias, -15 dBm Input Power	0.01	20	-	14	-	dB
Noise Figure	-30 dBm Input Power	0.01	20	-	5	-	dB
Output IP3	8V/7V bias, -15 dBm Input Power	0.01	20	-	24	-	dBm
Output P1dB	8V/7V bias	0.01	20	-	23	-	dBm
Output Power <sup>4</sup>	8V/7V bias	0.01	0.1	-	20	-	dBm
Output Power <sup>5</sup>	8V/7V bias	0.1	15	19	25	-	dBm
Output Power <sup>6</sup>	8V/7V bias	15	20	-	23	-	dBm
Output Return Loss	8V/7V bias, -15 dBm Input Power	0.01	20	-	20	-	dB
Phase Noise @ 10 kHz Offset	+12 dBm Input power	1	1	-	-167	-	dBc/Hz
Reverse Isolation	8V/7V bias, -15 dBm Input Power	0.01	20	-	36	-	dB
Small Signal Gain	8V/7V bias, -15 dBm Input Power	0.01	15	10	14	-	dB
Small Signal Gain	8V/7V bias, -15 dBm Input Power	15	20	-	12	-	dB

[1][2][3] Bias conditions for Ic and Ib tested with no RF input power. See performance plots for DC current vs. RF power. Bias conditions presented as VC/VB.

[4][5][6] Saturated Output Power specification defined using the APM-7099PA P3dB compression curve shown in the typical performance plots.

### Typical Performance Plots

Operation above Max Ic Limit = 180mA, will result in reduced MTTF

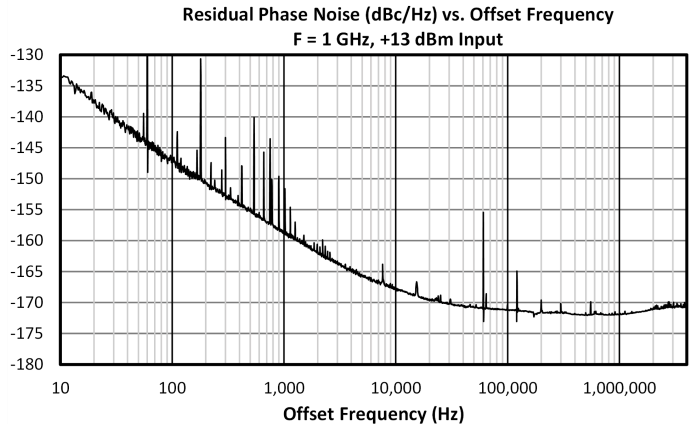
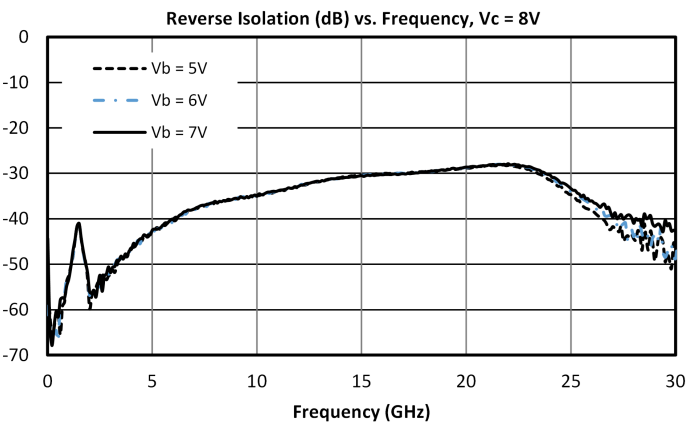
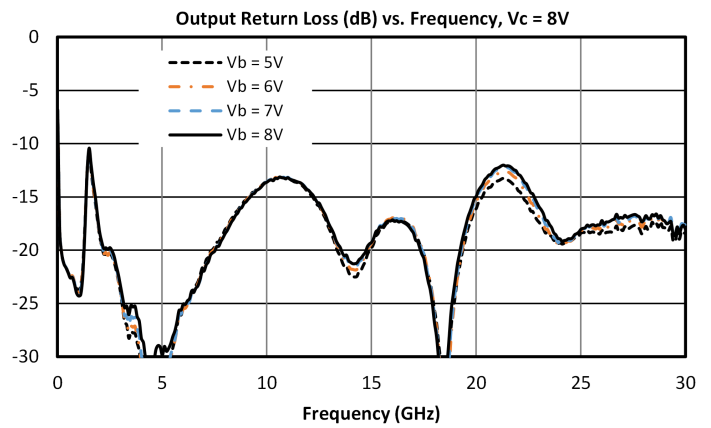
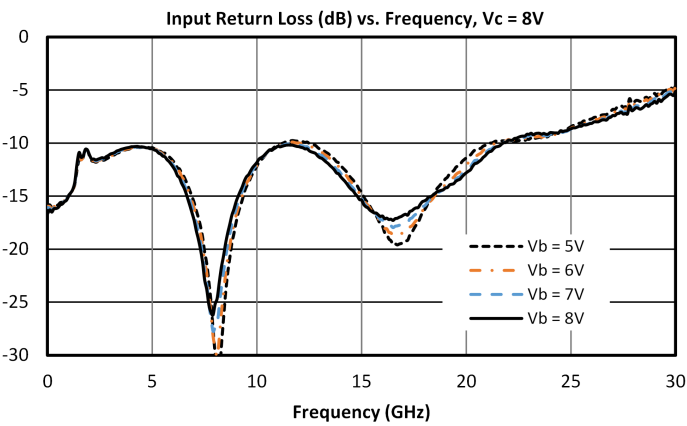
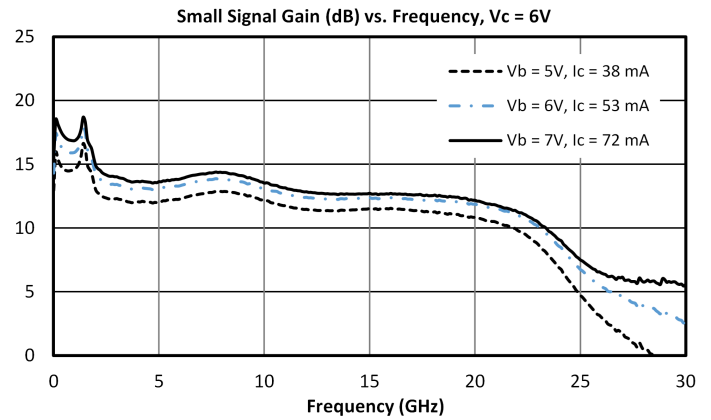
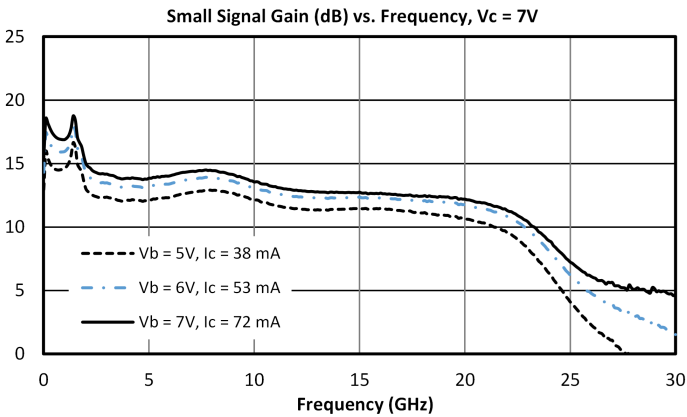
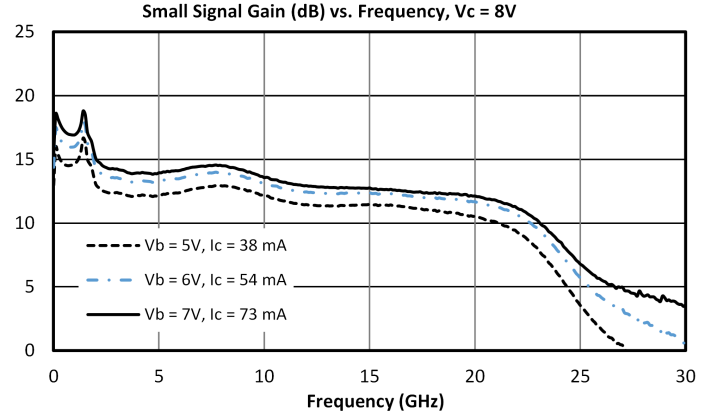
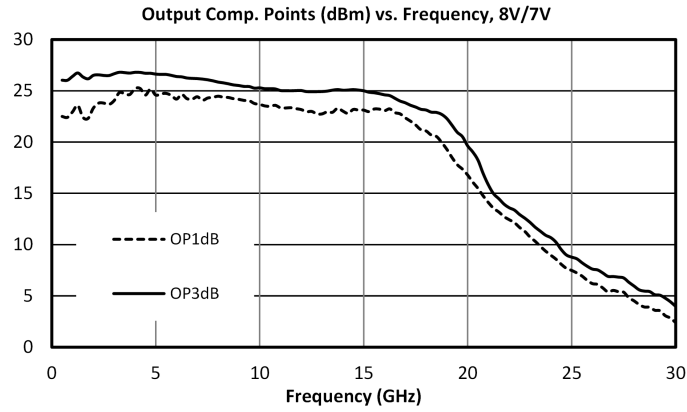

# APM-7099PA

## 0.01GHz – 20 GHz Low Phase Noise Amplifier

Saturated Output Power (dBm) vs. Frequency, Over Temperature, 8V/7V

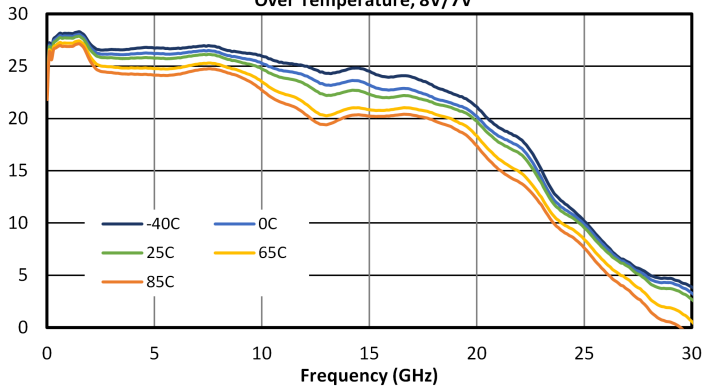

Noise Figure (dB) vs. Frequency

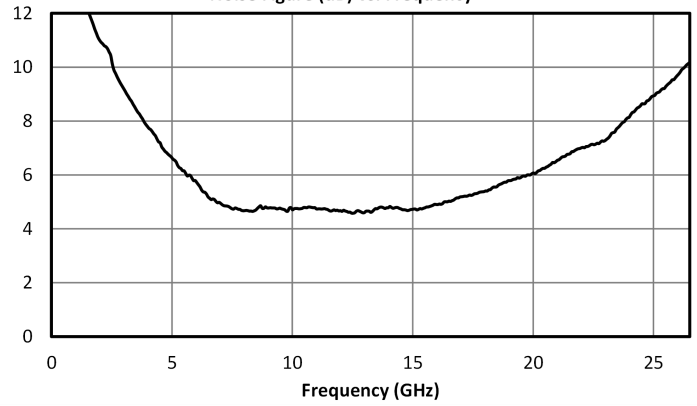

Small Signal Gain (dB) vs. Frequency, Over Temperature, 8V/7V

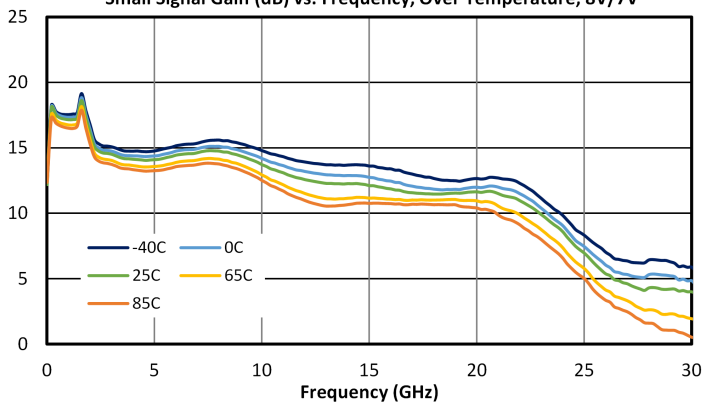

Harmonic Response (dBm) vs. Input Frequency, +10 dBm input, 8V/7V

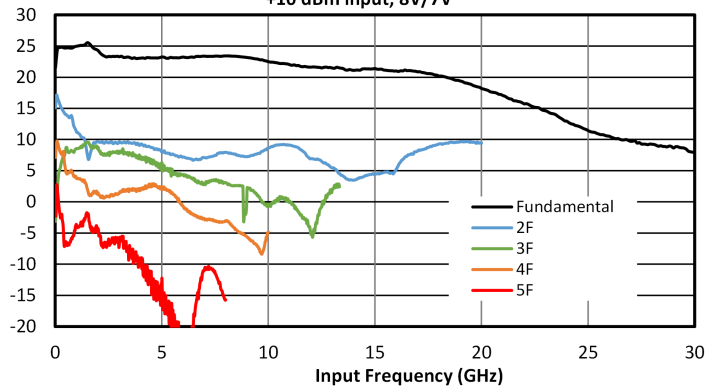

OIP3 (dBm) vs. Frequency, -15 dBm Input

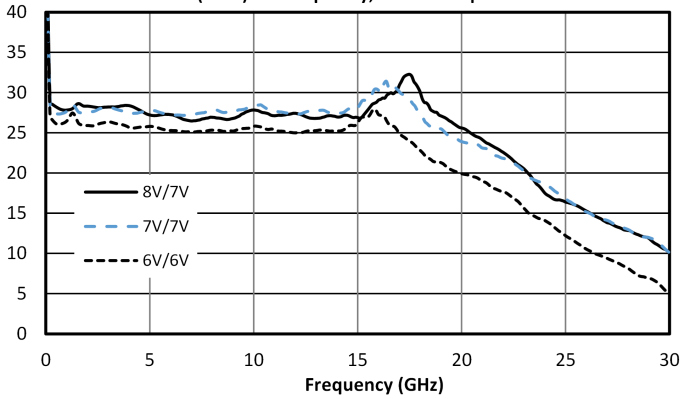

IIP3 (dBm) vs. Frequency, -15 dBm Input

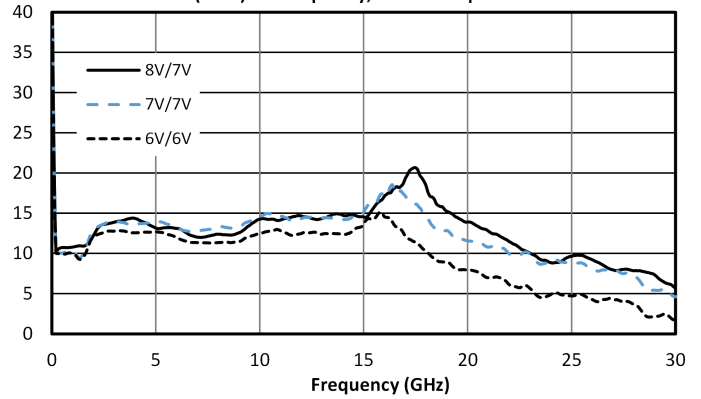

PAE, Gain, and Output Power vs. RF Input Power, 8V/7V, F = 5 GHz

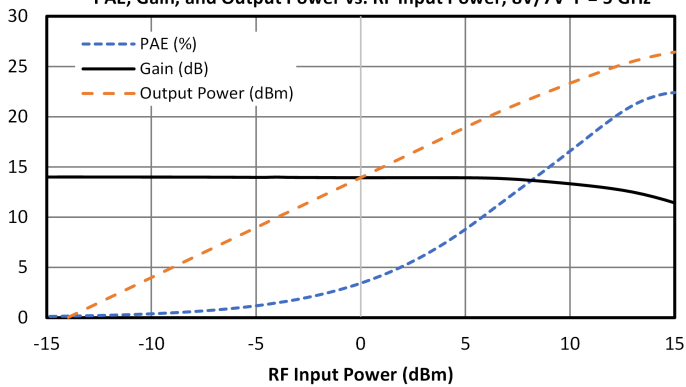

PAE, Gain, and Output Power vs. RF Input Power, 8V/7V, F = 15 GHz

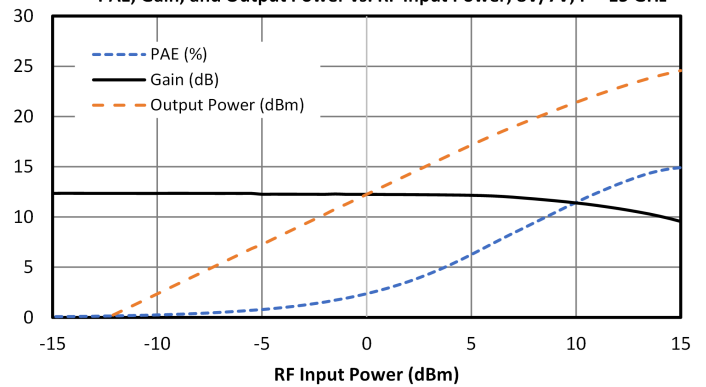

# APM-7099PA

## 0.01GHz – 20 GHz Low Phase Noise Amplifier

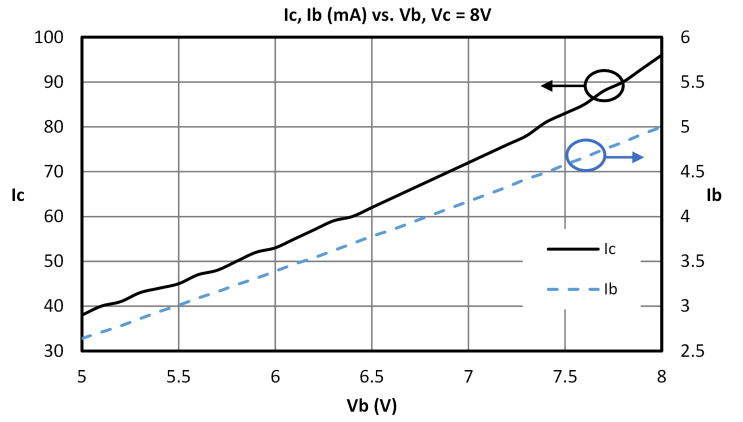
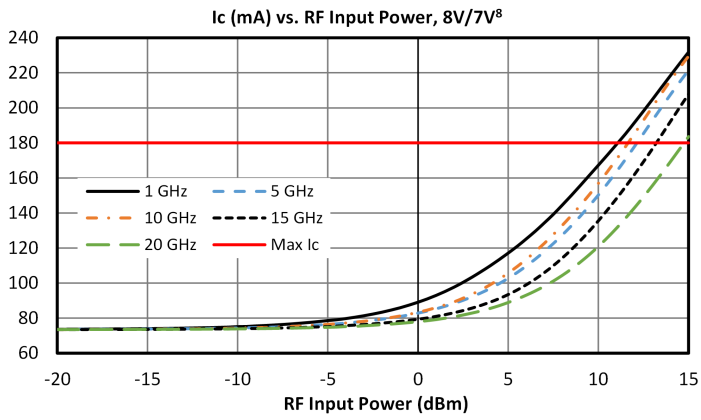

### Typical Performance Plots of Marki MT3H-0113H with APM 7099PA LO Driver

LO Input Powers specified as the input power into the APM-7099PA LO driver

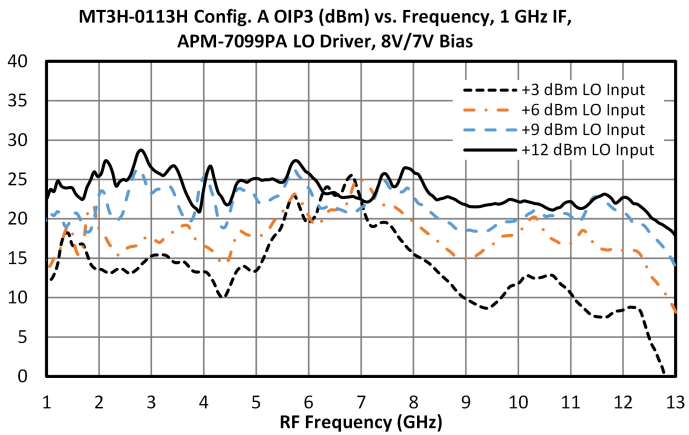
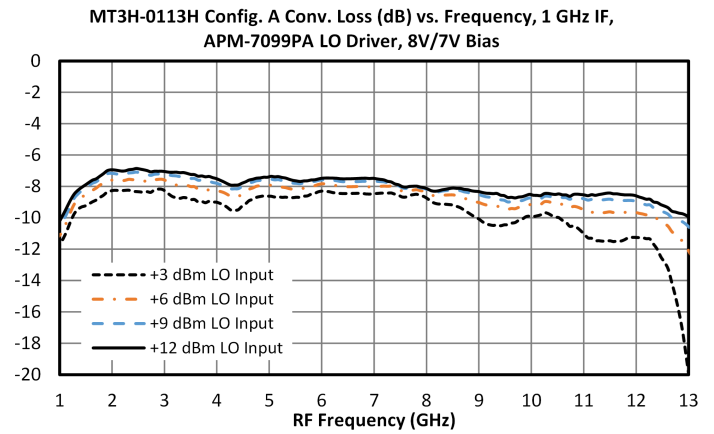
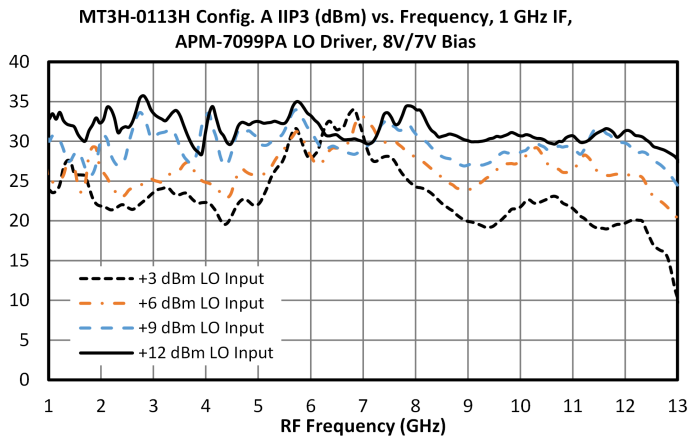

**Time Domain Plots**

Fast rise time is desirable for linear T3 mixer operation.

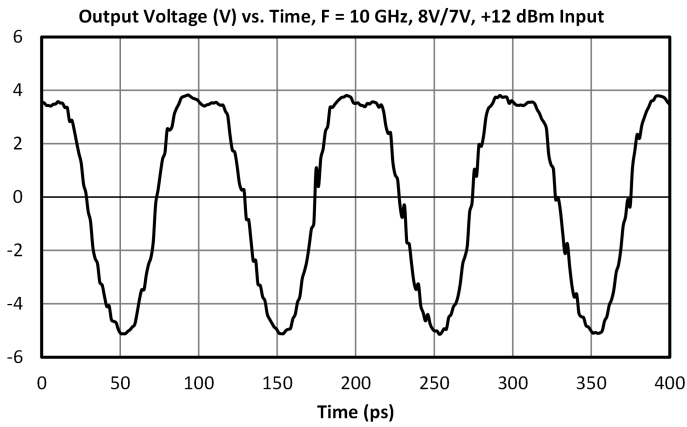
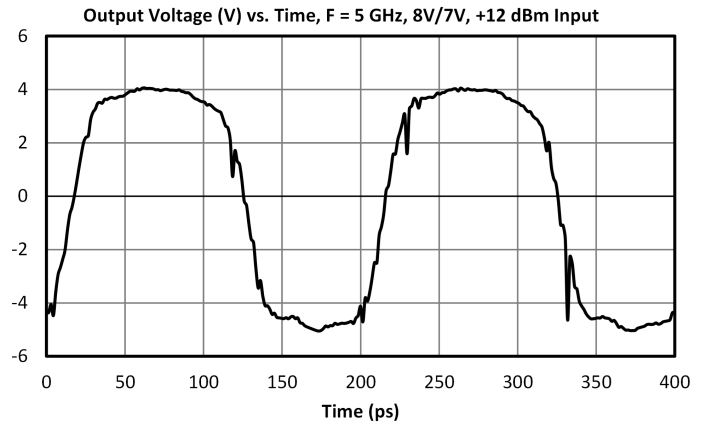
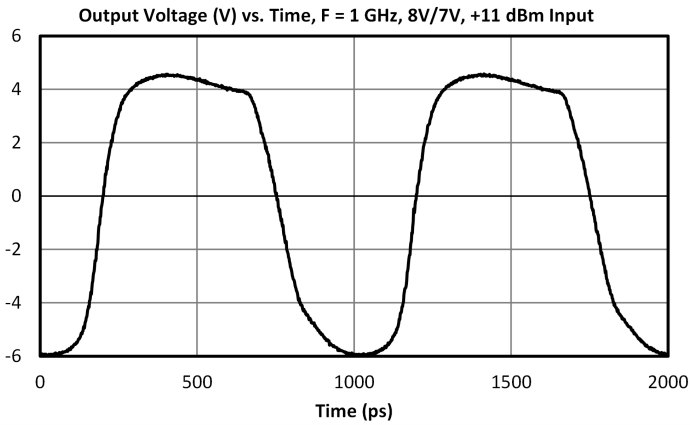

## APM-7099PA

0.01GHz – 20 GHz Low Phase Noise Amplifier

### Mechanical Data

### Outline Drawing

Download : [Outline 2D Drawing](#) | [Outline 3D Drawing](#) | [Outline 3D STP](#)

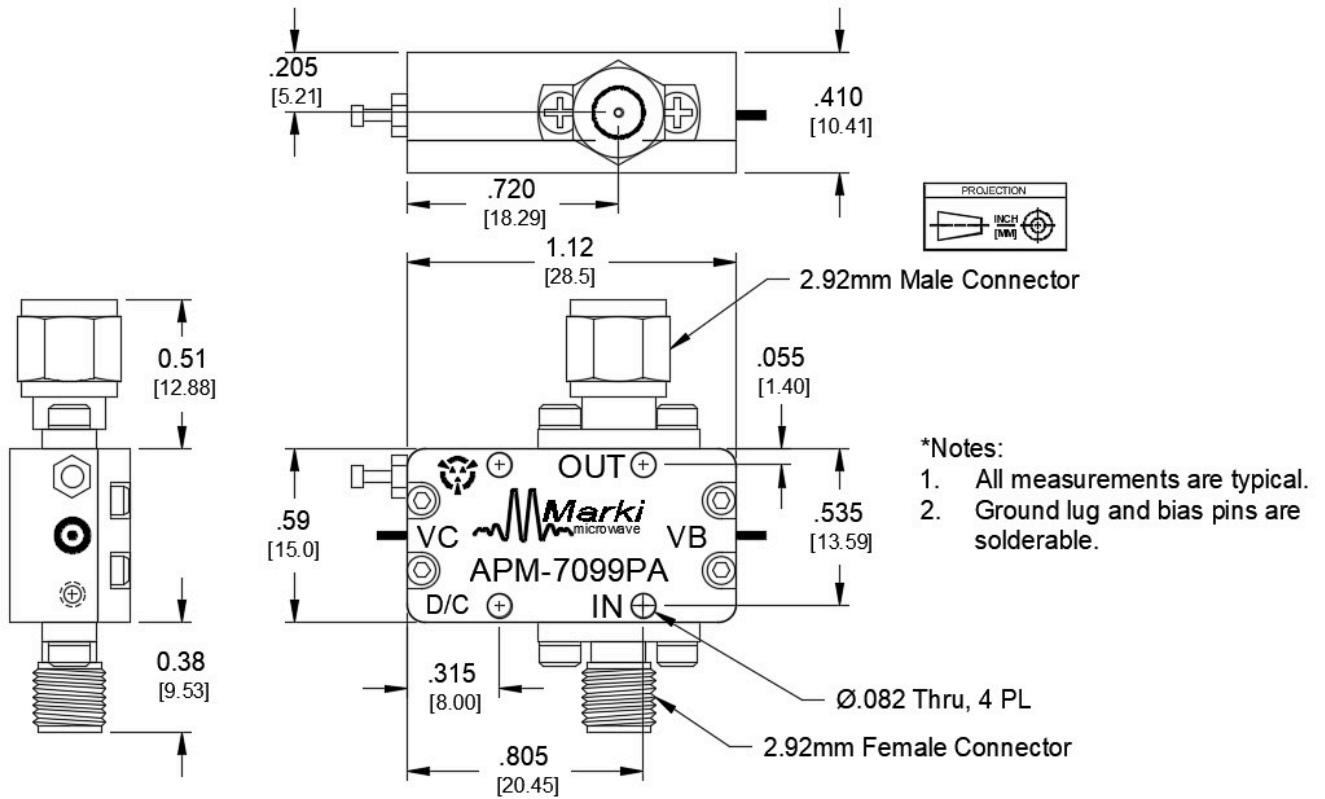

## Notes

The APM-7099's harmonic generation can be controlled by adjusting the supply and bias voltages. Decreasing the base voltage VB will increase the even harmonic generation and odd harmonic suppression. To increase the odd harmonic generation and even harmonic suppression, decrease the collector voltage VC. The optimal bias condition for even harmonic generation is VC=8V and VB=5V, while the optimal bias condition for odd harmonic generation is VC=5V and VB=8V.

## DISCLAIMER

MARKI MICROWAVE, INC., ("MARKI") PROVIDES TECHNICAL SPECIFICATIONS AND DATA (INCLUDING DATASHEETS), APPLICATION OR OTHER DESIGN ADVICE, WEB TOOLS, AND OTHER INFORMATION AND RESOURCES "AS IS" AND WITH ALL FAULTS. MARKI DISCLAIMS ALL WARRANTIES, EXPRESS OR IMPLIED, INCLUDING, WITHOUT LIMITATION, ANY IMPLIED WARRANTIES OF MERCHANTABILITY, FITNESS FOR A PARTICULAR PURPOSE, OR NON-INFRINGEMENT. These resources are intended for developers skilled in the art designing with Marki products. You are solely responsible for (1) selecting the appropriate products for your application, (2) designing, validating, and testing your application, and (3) ensuring your application meets applicable standards and other requirements. Marki makes no guarantee regarding the suitability of its products for any particular purpose, nor does Marki assume any liability whatsoever arising out of your use or application of any Marki product.

Marki grants you permission to use these resources only for development of an application that uses Marki products. Other reproduction or use of these resources is strictly prohibited. No license is granted to any other Marki intellectual property or to any third-party intellectual property. Marki reserves the right to make changes to the product(s) or information contained herein without notice.

MARKI MICROWAVE and T3 MIXER are trademarks or registered trademarks of Marki Microwave, Inc. All other trademarks used are the property of their respective owners.

© 2020 - 2021, 2023, Marki Microwave, Inc