

## 25-50 GHz GaAs Surface Mount LO Driver Amplifier

## AMM-7210SM

### 1. Device Overview

#### 1.1 General Description

The AMM-7210SM is a surface-mount amplifier suitable for use as a single tone driver or general-purpose gain block. It can drive an L or H diode mixer from 25 to 50 GHz, or S diode mixer from 27 to 50 GHz. This amplifier also has exceptionally low input and output reflections, and a positive gain slope. The AMM-7210SM is packaged in a compact 3mm QFN for surface mount integration onto printed circuit boards.

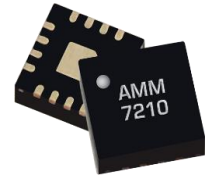

Surface Mount QFN

Note: Not recommended, see [AMM-8211](#) for new design. Email [support](#) for any questions.

#### 1.2 Features

- +15 dB Small Signal Gain
- +23 dBm saturated output power
- Excellent return losses
- Compact 3mm QFN package
- .s2p S-Parameters: [EVAL-AMM-7210SM.s2p](#)

#### 1.3 Applications

- Mobile test and measurement equipment
- Radar and satellite communications
- 5G transceivers
- LO driver for Marki L-, H-, and S-diode mixers

#### 1.4 Functional Block Diagram

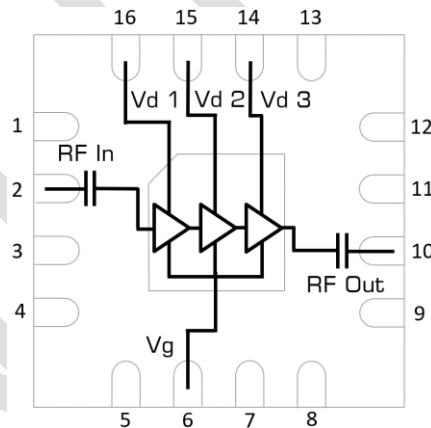

#### 1.5 Part Ordering Options<sup>1</sup>

Part Number	Description	Package	Green Status	Product Lifecycle	Export Classification
AMM-7210SM	3x3 mm Surface Mount	QFN	RoHS	Active	3A001.b.2.d
EVAL-AMM-7210SM	Connectorized Evaluation Fixture	EVAL	RoHS	Active	EAR99

<sup>1</sup> Refer to our [website](#) for a list of definitions for terminology presented in this table.

## Table of Contents

1. Device Overview .....	1	3.6 Typical Performance Plots .....	9
1.1 General Description .....	1	3.7 Typical Performance Plot of Marki MM1-1857H Using AMM-7210SM as LO Driver .....	11
1.2 Features .....	1	3.8 Typical Performance Plot of Marki MMIQ-1867LSM and MMIQ-1867HSM Using AMM-7210SM as LO Driver .....	12
1.3 Applications .....	1	4. Application Information .....	13
1.4 Functional Block Diagram .....	1	4.1 Example Application Circuit .....	13
1.5 Part Ordering Options .....	1	4.2 Constant Current and Constant Voltage Operation .....	14
2. Port Configurations and Functions .....	3	4.3 Header Pinouts .....	15
2.1 Port Diagram .....	3	5. Mechanical Data .....	15
2.2 Port Functions .....	4	5.1 SMT Package Outline Drawing .....	15
3. Specifications .....	5	5.2 AMM-7210SM Recommended PCB Footprint .....	16
3.1 Absolute Maximum Ratings .....	5	5.3 EVAL Package Outline Drawing .....	17
3.2 Package Information .....	5		
3.3 Recommended Operating Conditions .....	6		
3.4 Sequencing Requirements .....	6		
3.5 Electrical Specifications .....	7		
3.6 Typical Performance Plots, Bias: $V_{d1} =$ $V_{d2} = 3V$ , $V_{d3} = 3.5V$ , $V_g = -0.5V$ .....	8		

### Revision History

Revision Code	Revision Date	Comment
-	June 2021	Datasheet Initial Release



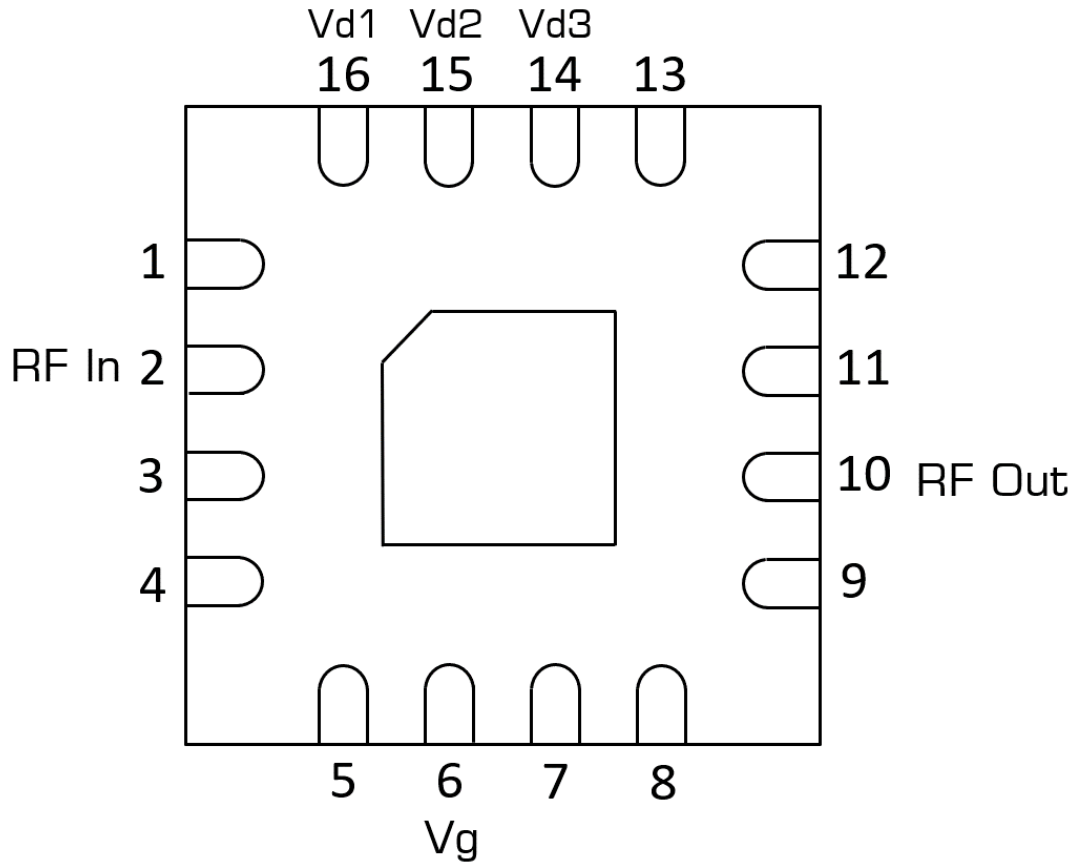

## 2. Port Configurations and Functions

### 2.1 Port Diagram

A port diagram of the AMM-7210SM's QFN package is shown below. The pin functions are detailed in section 2.2 of this datasheet.

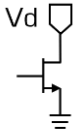
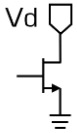
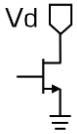

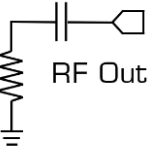
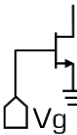
## 2.2 Port Functions

Port	Function	Description	Equivalent Circuit for Package
Pin 14 <sup>2</sup>	Positive DC Supply $V_d$	Pin 14 provides +2.5V to +4V DC voltage to the amplifier's third stage. <b>Negative voltage must be supplied to Pin 6 before turning on the positive supply voltage.</b>	
Pin 15 <sup>2</sup>	Positive DC Supply $V_d$	Pin 15 provides +2.5V to +4V DC voltage to the amplifier's second stage. <b>Negative voltage must be supplied to Pin 6 before turning on the positive supply voltage.</b>	
Pin 16 <sup>2</sup>	Positive DC Supply $V_d$	Pin 16 provides +2.5V to +4V DC voltage to the amplifier's first stage. <b>Negative voltage must be supplied to Pin 6 before turning on the positive supply voltage.</b>	
Pin 2	RF Input	Pin 2 is the RF input of the amplifier, and is matched to 50 ohms. It is internally DC blocked.	
Pin 10	RF Output	Pin 10 is the RF output of the amplifier, and is matched to 50 ohms. It is internally DC blocked.	
Pin 6 <sup>3</sup>	Negative DC Supply $V_g$	Pin 6 provides -0.4V to -0.6V of DC voltage. This must be turned on before turning on the positive supply voltage to Pin 1.	
GND	Ground	Ground paddle and non-connected pins must be connected to a DC/RF ground potential with high thermal and electrical conductivity, and low inductance.	

<sup>2</sup> Pins 14, 15, and 16 may be biased together for ease of use, or individually to adjust overall performance

<sup>3</sup> Pin 6 may be biased with constant DC voltage, or actively biased to produce a fixed  $I_d$  for consistent performance.

### 3. Specifications

#### 3.1 Absolute Maximum Ratings

The Absolute Maximum Ratings indicate limits beyond which damage may occur to the device. If these limits are exceeded, the device may be inoperable or have a reduced lifetime. This amplifier is designed and characterized in a 50Ω system, and operation in a reflective environment can cause performance degradation.

Parameter	Maximum Rating	Units
Positive Drain Supply Voltage (Pin 14, 15, 16)	4.5	V
Negative Bias Voltage (Pin 6)	-2	V
RF Input Power	+20	dBm
Positive Drain Supply Current <sup>4</sup> (with RF Input)	450	mA
Operating Temperature	-40 to +85	°C
Storage Temperature	-65 to +150	°C
Thermal Resistance, $\theta_{JC}$	94	°C/W
Continuous Power Dissipation ( $P_{DISS}$ ) (at 85 °C case temp.) <sup>5</sup>	1	W
Max Junction Temperature for MTTF > 1E6 hours	175	°C

#### 3.2 Package Information

Parameter	Details	Rating
Weight	EVAL Package	31.2g

<sup>4</sup> Positive Drain Supply DC current is specified as  $I_{d1} + I_{d2} + I_{d3}$

<sup>5</sup> Derates by 11 mW/°C above 85 °C case temperature.

### 3.3 Recommended Operating Conditions

The Recommended Operating Conditions indicate the limits, inside which the device should be operated, to guarantee the performance given in Electrical Specifications (3.5). Operating outside these limits may not necessarily cause damage to the device, but the performance may degrade outside the limits of the Electrical Specifications. For limits, above which damage may occur, see Absolute Maximum Ratings (3.1).

Parameter	Min	Nominal	Max	Units
T <sub>A</sub> , Ambient Temperature	-40	+25	+85	°C
Power Supply DC Voltage Vd1	+2.5	+3	+4	V
Power Supply DC Voltage Vd2	+2.5	+3	+4	V
Power Supply DC Voltage Vd3	+2.5	+3.5	+4	V
Power Supply DC Current (no RF Input) <sup>6</sup>	115	180	300	mA
Gate Bias DC Voltage	-0.6	-0.5	-0.4	V
Input Power for Saturation	+8	+11	+13	dBm

### 3.4 Sequencing Requirements

Turn-on Procedure:

- 1) Apply V<sub>g</sub> (Pin 6)
- 2) Apply V<sub>d</sub> (Pin 14, 15, 16)

Turn-off Procedure:

- 1) Turn off V<sub>d</sub> (Pin 14, 15, 16)
- 2) Turn off V<sub>g</sub> (Pin 6)

**Note:** RF input power can be injected at any moment in the bias sequencing procedure.

<sup>6</sup> Power Supply DC current is specified as I<sub>d1</sub> + I<sub>d2</sub> + I<sub>d3</sub>

### 3.5 Electrical Specifications<sup>7</sup>

The electrical specifications apply at  $T_A=+25^{\circ}\text{C}$  in a  $50\Omega$  system.

QFNs are 100% RF tested.

Parameter	Test Conditions	Frequency	Min	Typical	Units
Saturated Output Power <sup>8</sup>	Vd1 = Vd2 = +3V, Vd3 = +3.5V, Vg = -0.5V Bias	25 GHz – 35 GHz		+20	dBm
		35 GHz – 45 GHz	+17	+23	
		45 GHz – 50 GHz		+21	
Small Signal Gain	Vd1 = Vd2 = +3V, Vd3 = +3.5V, Vg = -0.5V Bias -20 dBm Input Power	25 GHz – 35 GHz		13	dB
Input Return Loss		35 GHz – 45 GHz	9	15	
		45 GHz – 50 GHz		15	
Output Return Loss		25 GHz – 50 GHz		14	
Reverse Isolation		25 GHz – 50 GHz		16	
Noise Figure	Vd1 = Vd2 = +3V, Vd3 = +3.5V, Vg = -0.5V Bias	25 GHz – 50 GHz		5.6	
Drain Current <sup>9</sup> , Id	Vd1 = Vd2 = +3V, Vd3 = +3.5V, Vg = -0.4V	-		230	mA
	Vd1 = Vd2 = +3V, Vd3 = +3.5V, Vg = -0.5V	-		180	
	Vd1 = Vd2 = +3V, Vd3 = +3.5V, Vg = -0.6V	-		130	
Input IP3 (IIP3)	Vd1 = Vd2 = +3V, Vd3 = +3.5V, Vg = -0.5V Bias	25 GHz – 50 GHz		+11	dBm
Output IP3 (OIP3)		25 GHz – 50 GHz		+26	
Output P <sub>1dB</sub>	Vd1 = Vd2 = +3V, Vd3 = +3.5V, Vg = -0.5V Bias	25 GHz – 50 GHz		+20	
Input Power for Saturation	Vd1 = Vd2 = +3V, Vd3 = +3.5V, Vg = -0.5V Bias	25 GHz – 50 GHz		+11	dBm

<sup>7</sup> Evaluation board losses are mathematically extracted from Saturated output power, Small signal gain, Noise figure, and IIP3/OIP3 specifications.

<sup>8</sup> Saturated output power specification defined using the EVAL-APM-7210SM P<sub>5dB</sub> compression curve shown in section 3.6

<sup>9</sup> Bias conditions for Id tested with no RF input power. See section 3.6 for DC current vs. RF power. Bias conditions presented as Vd/Vg. Drain current is specified as Id<sub>1</sub> + Id<sub>2</sub> + Id<sub>3</sub>

### 3.6 Typical Performance Plots<sup>10 11</sup>, Bias: $V_{d1} = V_{d2} = 3V$ , $V_{d3} = 3.5V$ , $V_g = -0.5V$

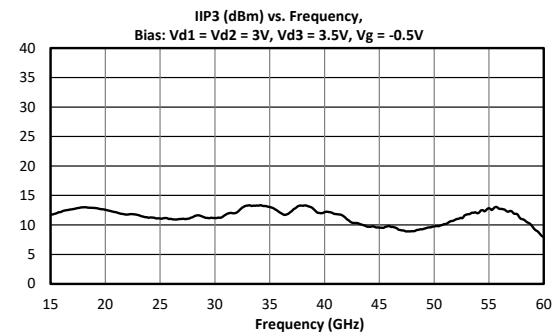
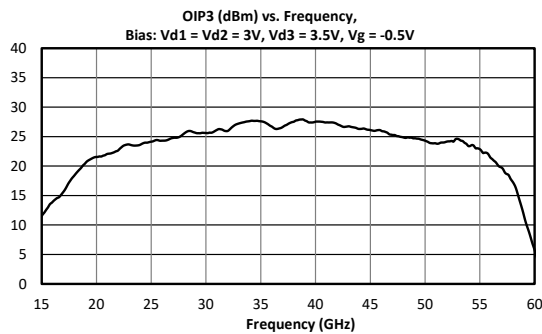
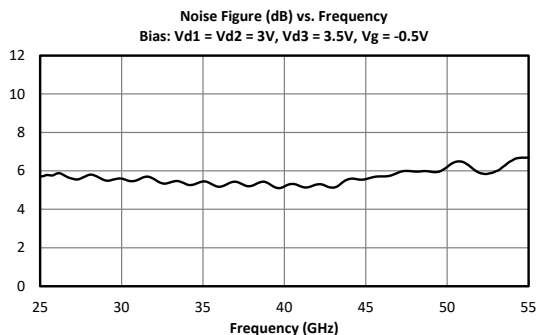
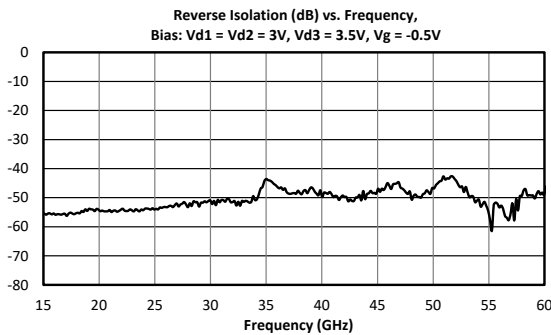
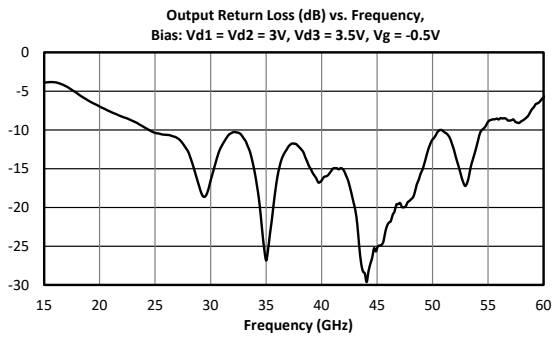
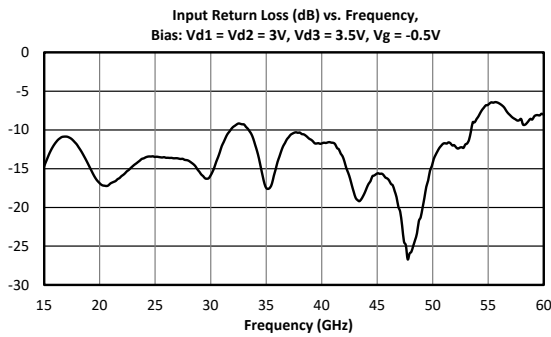
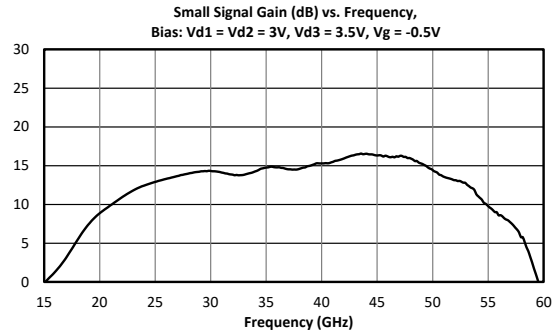
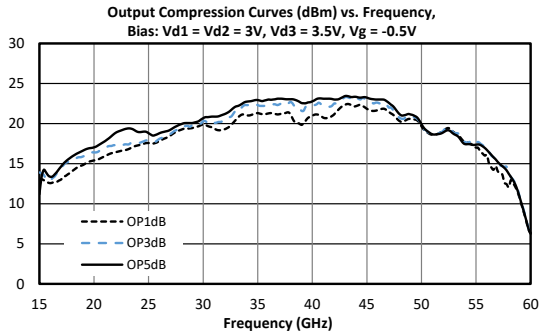

<sup>10</sup> Measurement data taken using the EVAL-AMM-7210SM module.

<sup>11</sup> Evaluation board losses are mathematically extracted out of Output Compression Curves, Small Signal Gain, Noise Figure, and IP3 plots.

### 3.6 Typical Performance Plots<sup>12</sup>

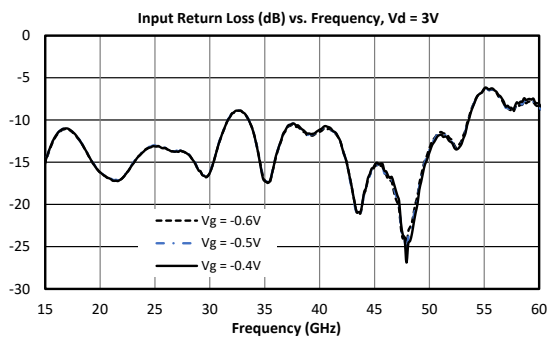
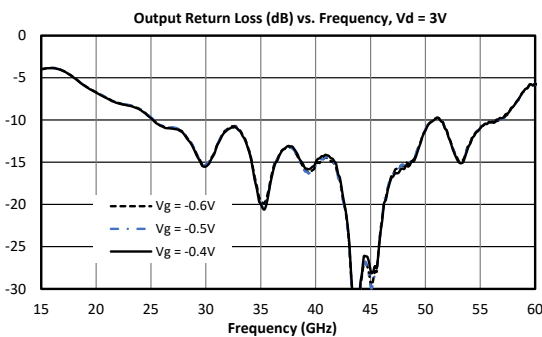
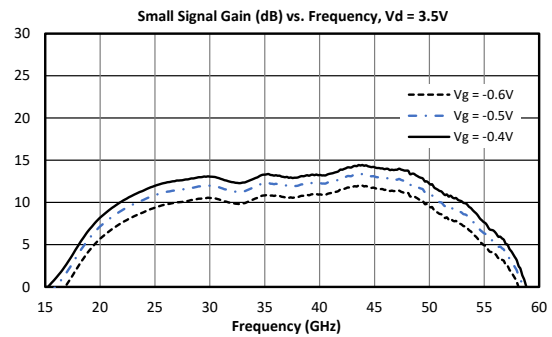
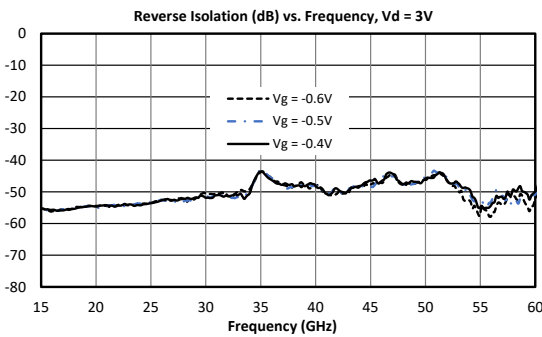
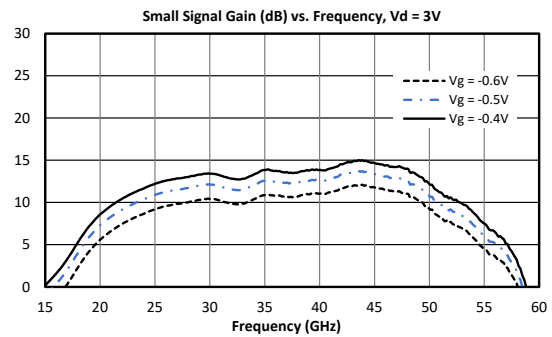
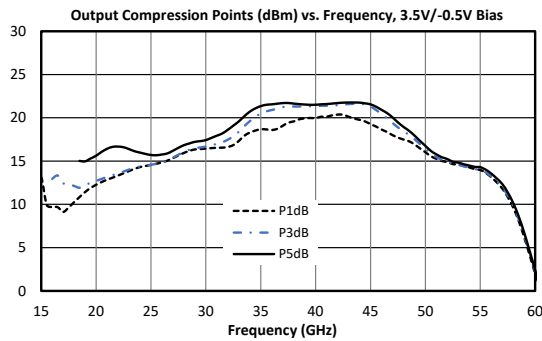
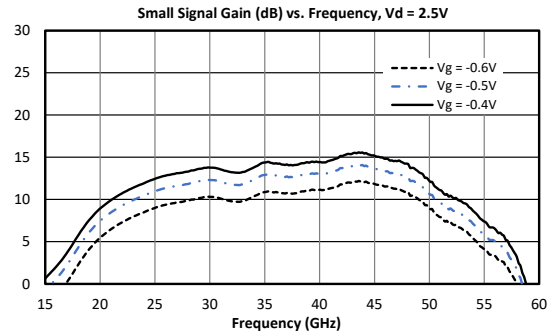
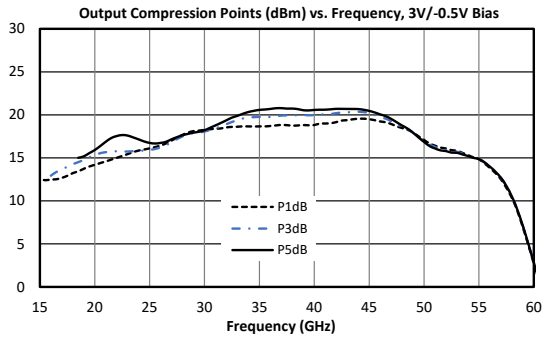

<sup>12</sup> Measurement data taken using the EVAL-AMM-7210SM module.

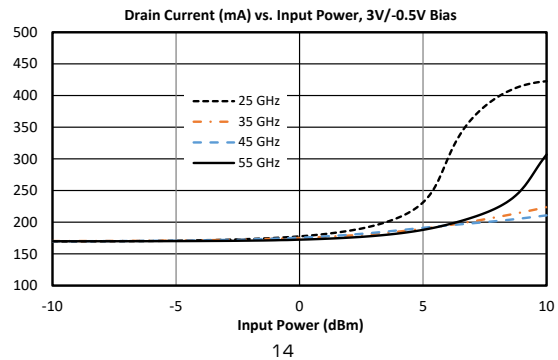
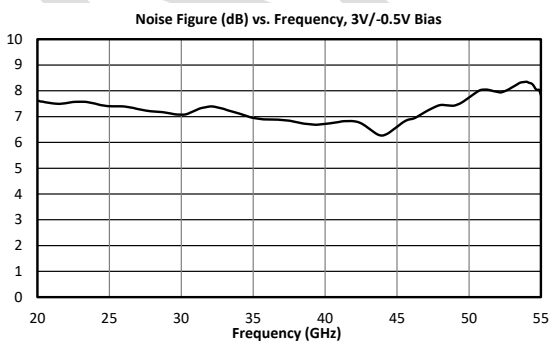
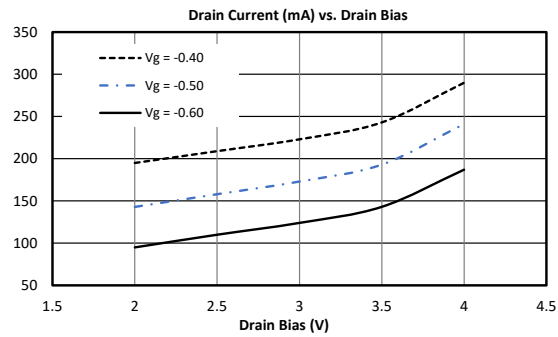
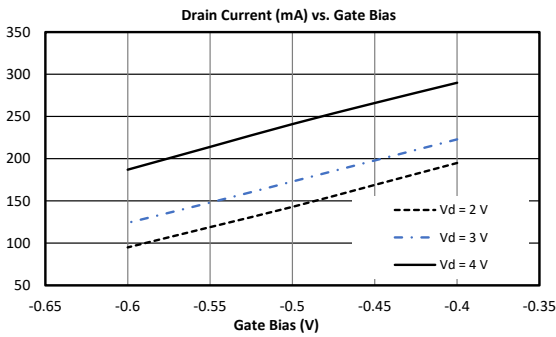
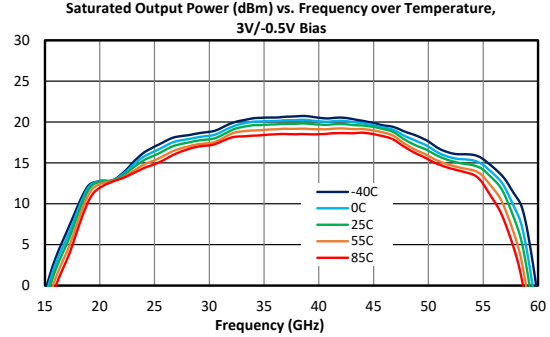
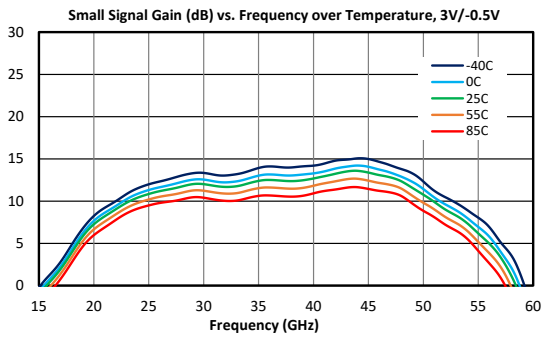
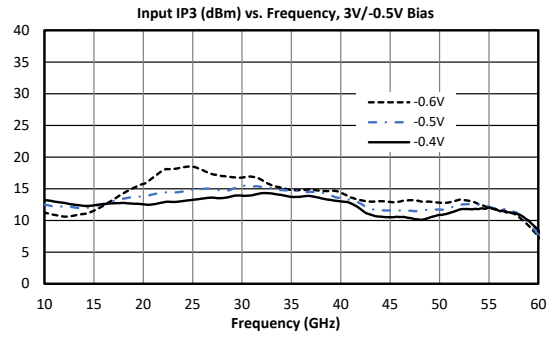
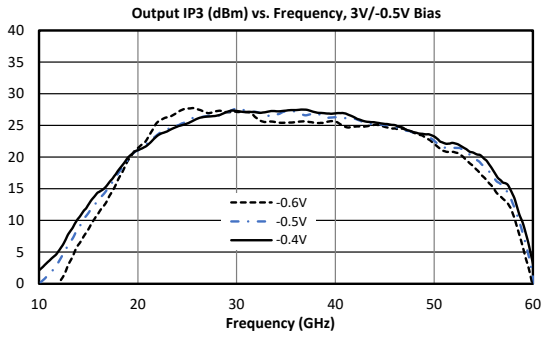

<sup>14</sup> Drain current is specified as  $I_{d1} + I_{d2} + I_{d3}$

### 3.7 Typical Performance Plot of Marki MM1-1857H Using AMM-7210SM as LO Driver<sup>15</sup>

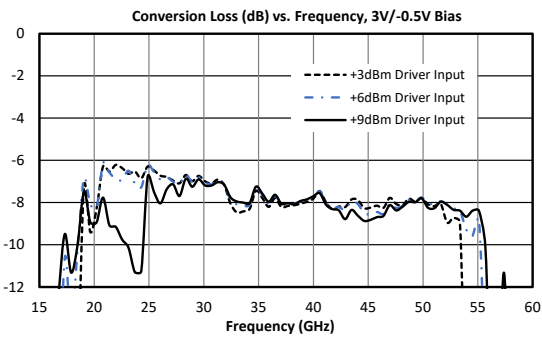
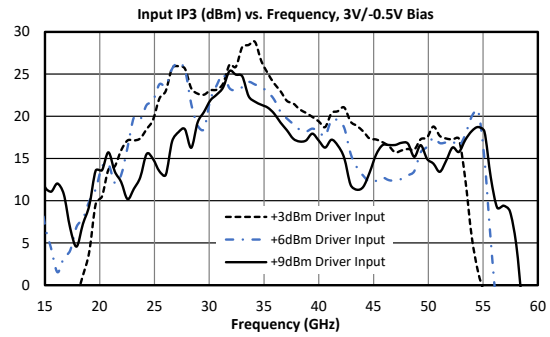
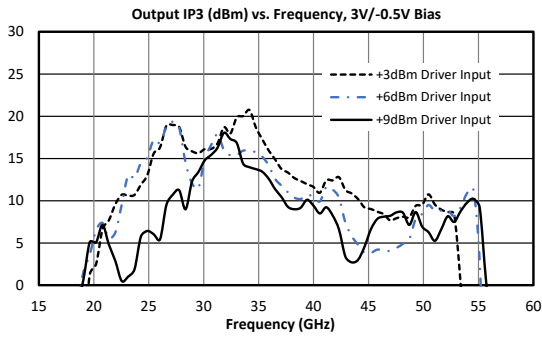

Intentionally left blank

<sup>15</sup> Plots taken using EVAL-AMM-7210SM as LO driver for connectorized MM1-1857H module in configuration A with a 91MHz IF. Power specified is input power to EVAL-AMM-7210SM driver.

### 3.8 Typical Performance Plot of Marki MMIQ-1867LSM and MMIQ-1867HSM Using AMM-7210SM as LO Driver<sup>16</sup>

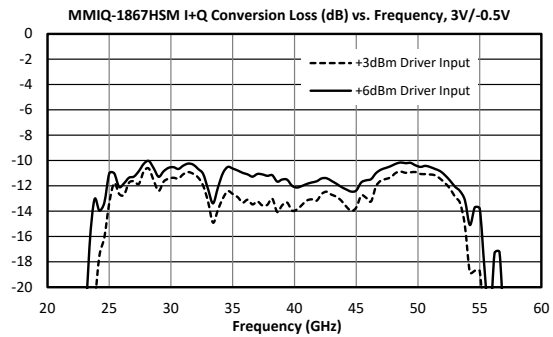
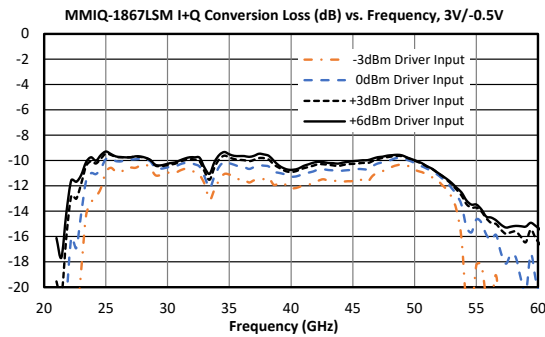

<sup>16</sup> Plots taken using EVAL-AMM-7210SM as LO driver for the EVAL-MMIQ-1867LSM in configuration A with a 6GHz IF. Power specified is input power to EVAL-AMM-7210SM driver.

## 4. Application Information

### 4.1 Example Application Circuit

Below is the recommended application circuit for the AMM-7210SM:

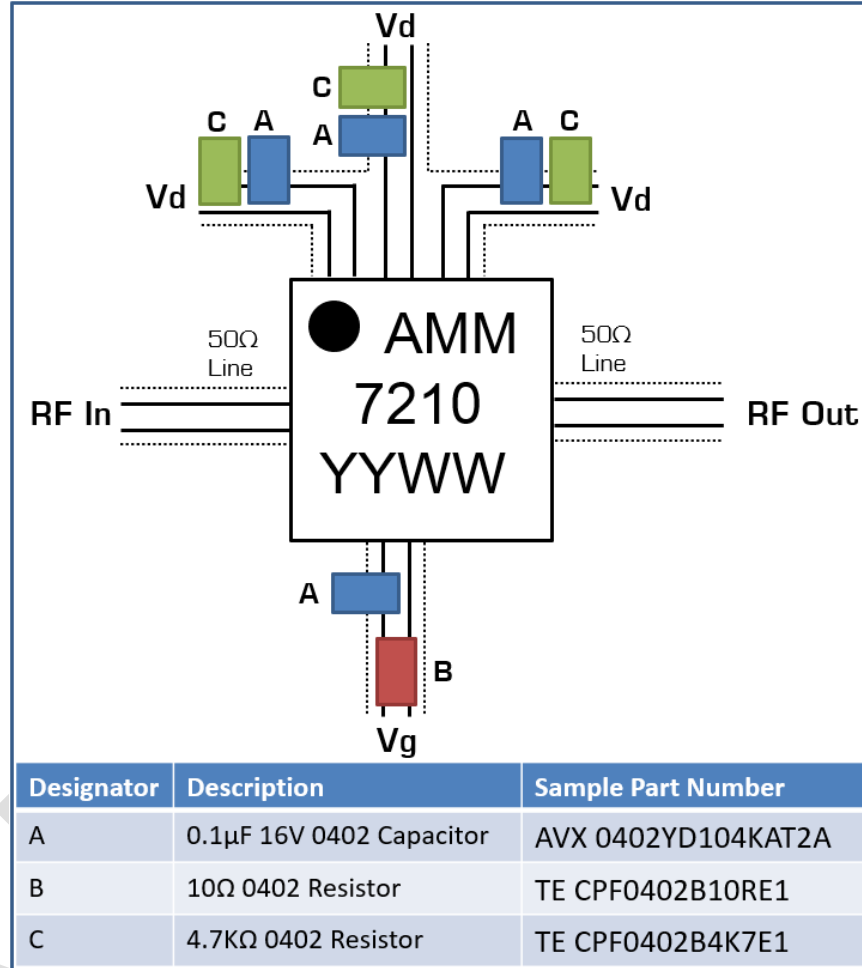

The three Vd lines are separated to minimize feedback between the transistor's stages. The passive devices should be 0402 or 0201 surface mount. Examples of suitable passive devices would be the AVX 0402YD104KAT2A capacitor and TE CPF0402B10RE1 resistor. In addition to the resistor and capacitor on the gate pin, the layout of the board should be designed to minimize stray coupling between the drain and gate biasing traces on the board. Additionally, the gate biasing pin AMM-7210SM can draw up to 0.5mA at certain combinations of frequency and input power.

---

## 4.2 Constant Current and Constant Voltage Operation

As with most amplifiers utilizing HEMT technology, the AMM-7210SM can be biased with a constant gate and drain voltage, or with a constant drain current by regulating the gate voltage. Using a constant gate and drain voltage for biasing reduces complexity, but has variable current consumption during operation. On the other hand, biasing the gate using a feedback network that samples the drain current minimizes unit-to-unit variation in gain and other parameters.

Under small signal excitation at a fixed temperature, these two approaches are equivalent. However, they will diverge in large signal conditions, where the drain current is affected by the frequency and power of the input signal. In these conditions P1dB, P3dB, and P5dB will be somewhat different, but based on tests with similar parts, they will be within a few dBm of the constant voltage curves.

### 4.3 Header Pinouts

On the EVAL-AMM-7210SM, there are two headers for biasing the drains and gates of the transistors. The pinout of the headers is given with their location on the evaluation board below:

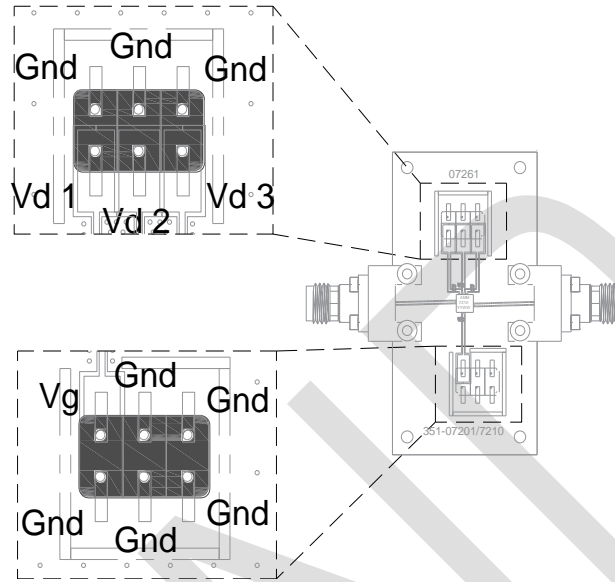

## 5. Mechanical Data

### 5.1 SMT Package Outline Drawing

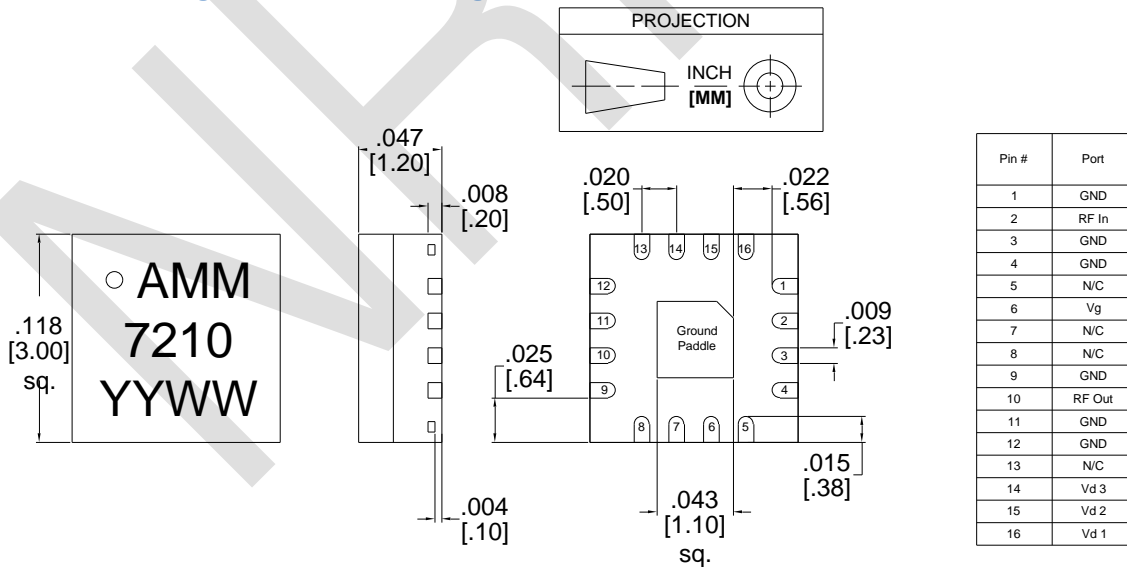

Notes:

- 1) QFN material is plastic
- 2) I/O Leads and Die Paddle are 0.05 microns Au over 0.02 microns Pd over 0.5 microns Ni
- 3) All unconnected pins should be connected to PCB RF ground.

## 5.2 AMM-7210SM Recommended PCB Footprint

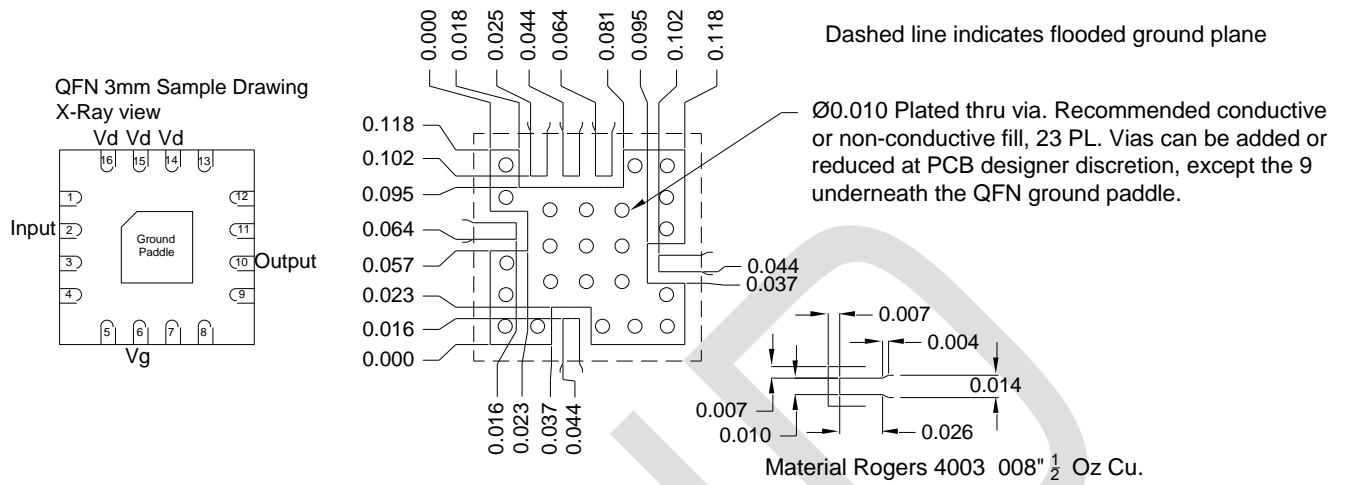

Landing pattern .dxf drawing: [Landing Pattern AMM7210SM.dxf](#)

### 5.3 EVAL Package Outline Drawing

