

ADM-8622PSM

DC - 10 GHz High Dynamic Range Gain Block

DEVICE OVERVIEW

General Description

The ADM-8622PSM is a high-linearity low noise amplifier capable of providing 15.5 dB gain, 2 dB noise figure and +26 dBm OIP3 up to 10 GHz. The amplifier is suitable for use in RF front-ends requiring low noise, high gain and excellent signal fidelity. The ADM-8622PSM performs well down to DC and its low frequency performance is limited only by the frequency response of the input and output bias tees present in the application circuit. The ADM-8622PSM is available in a very compact 1.3x2mm DFN package.

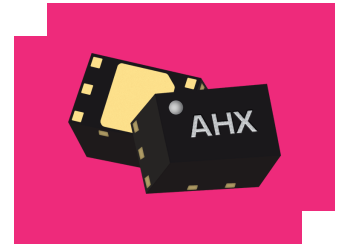

[Download s-parameters here](#)

Features

- 15.5 dB flat gain response
- +26 dBm output IP3
- 2.0 dB noise figure
- No negative bias required

Applications

- Mobile test and measurement equipment
- Radar and satellite communications
- 5G transceivers

Functional Block Diagram

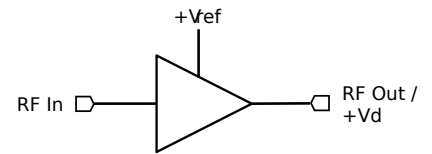

Part Ordering Options

Part Number	Description	Package	Green Status	Product Lifecycle	Export Classification
ADM-8622PSM	DC - 10 GHz High Dynamic Range Gain Block	DFN	REACH RoHS	Released	EAR99
EVB-ADM-8622P	Evaluation Board, DC - 10 GHz High Dynamic Range Gain Block Amplifier	EVB	REACH RoHS	Released	EAR99

Table Of Contents

- **Device Overview**
 - General Description
 - Features
 - Applications
 - Functional Block Diagram
- **Port Configuration and Functions**
 - Port Diagram
 - Port Functions
- **Revision History**
- **Specifications**
 - Absolute Maximum Ratings
 - Package Information
 - Recommended Operating Conditions
 - Electrical Specifications
 - Typical Performance Plots
- **Operation**
 - Application Information
 - Application Circuit
 - Application Circuit Description
- **Mechanical Data**
 - Outline Drawing
- **Footprint Image**
- **Evaluation Board**
 - Evaluation Board - Typical Performance Plots
 - Evaluation Board Outline Drawing

Revision History

Revision Code	Revision Date	Comment
-	2023-06-01	Initial Datasheet Release
A	2025-03-04	Corrected Application Circuit Voltage
B	2025-05-07	Updated Abs Max Drain Voltage from 4V to 7V

Port Configuration and Functions

Port Diagram

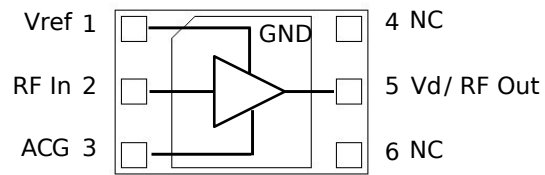

Port Functions

Port	Function	Description	DC Equivalent Circuit
Paddle	Gnd	Package ground paddle must be connected to a DC/RF ground potential with high thermal and electrical conductivity.	-
Pin 1	Vref	Pin 1 provides a voltage reference to bias Pin 2. Pin 1 and pin 2 must be DC coupled but RF isolated by a choke. For proper operation, DO NOT ground this pin nor leave it floating . See application section for more details.	-
Pin 2	RF Input	Pin 2 is the RF Input port of the amplifier. It is internally RF matched to 50 Ω and requires an external DC blocking cap. Pin 2 must be DC coupled to Pin 1 voltage reference through an RF choke for biasing.	-
Pin 3	ACG	Pin 3 should be AC grounded using a series RC network. See application section for details. DO NOT DC GROUND THIS PIN.	-
Pin 4,6	NC	Pin 4 and Pin 6 are internally no-connects and should be connected to DC/RF ground.	-
Pin 5	RF Out / Vd	Pin 5 is the RF Output port and is also the Vd port providing the main power supply to the amplifier. This pin is DC coupled and requires an external bias-T or discrete choke and DC blocking capacitor. This port is RF matched to 50 Ω . DC voltage at this pin should be set to 3.3V for normal operation.	-

Specifications

Absolute Maximum Ratings

The Absolute Maximum Ratings indicate limits beyond which damage may occur to the device. If any one of these limits are exceeded, the device may become inoperable or have a reduced lifetime. Reliability limits are individual, instantaneous catastrophic limits only. Functional operation limits are indicated below. Operation of the device at multiple absolute maximum limits or for extended periods at a single limit can cause degradation and damage to the device.

Parameter	Maximum Rating	Unit
Drain Bias Current (Idq)	60	mA
Drain Supply Voltage (Vd)	7	V
Maximum Operating Temperature for MTTF > 1E6 hours	85	°C
Maximum Storage Temperature	125	°C
Max Junction Temperature for MTTF of >1E6 hours	175	°C
Max Power Dissipation for MTTF of > 1E6 hours	0.72	W
Minimum Operating Temperature for MTTF > 1E6 hours	-40	°C
Minimum Storage Temperature	-65	°C
Reference Bias Current (Iref)	15	mA
Reference Bias Voltage (Vref)	2	V
RF Input Power	20	dBm
θ_{Jc} , Junction to Case Thermal Resistance	50	°C/W

Package Information

Parameter	Details	Rating
Weight	Package name: DFN	0.007g
Dimensions	-	2.0 x 1.3 mm
Moisture Sensitivity Level	-	MSL 1

Recommended Operating Conditions

The Recommended Operating Conditions indicate the limits, inside which the device should be operated, to guarantee the performance given in Electrical Specifications. Operating outside these limits may not necessarily cause damage to the device, but the performance may degrade outside the limits of the electrical specifications. For limits, above which damage may occur, see Absolute Maximum Ratings.

Parameter	Min	Nominal	Max	Unit
Ta Ambient Temperature	-40	25	85	°C
Power Supply DC Voltage (Vd)	-	3.3	-	V
Power Supply DC Current (Idq) (No RF Input)	-	40	-	mA
Input Power for Saturation	-	5	-	dBm

Electrical Specifications

Unless otherwise specified, electrical specifications apply at TA=+25°C and Vd = 3.3 V.

Parameter	Test Conditions	Minimum Frequency (GHz)	Maximum Frequency (GHz)	Min	Typ	Max	Unit
Current Consumption	Vd = 3.3 V no RF input	-	-	-	40	-	mA
Input IP2	Vd = 3.3 V Idq = 40mA Pin = -18 dBm per tone, 1 MHz tone spacing	0	10	-	14	-	dBm
Input IP3	Vd = 3.3 V Idq = 40mA Pin = -18 dBm per tone, 1 MHz tone spacing	0	10	-	11	-	dBm
Input Power for Saturation	Vd = 3.3 V Idq = 40mA	0	10	-	5	-	dBm
Input Return Loss	Vd = 3.3 V Idq = 40mA Pin = -20 dBm	0	10	-	16	-	dB
Noise Figure	Vd = 3.3 V Idq = 40mA Pin = -20 dBm	0.21	10	-	2	-	dB
Output IP2	Vd = 3.3 V Idq = 40mA Pin = -18 dBm per tone, 1 MHz tone spacing	0	10	-	29	-	dBm
Output IP3	Vd = 3.3 V Idq = 40mA Pin = -18 dBm per tone, 1 MHz tone spacing	0	10	-	26	-	dBm
Output P1dB	Vd = 3.3 V Idq = 40mA	0	10	-	13.5	-	dBm
Output Return Loss	Vd = 3.3 V Idq = 40mA Pin = -20 dBm	0	10	-	24	-	dB
Reverse Isolation	Vd = 3.3 V Idq = 40mA Pin = -20 dBm	0	10	-	19	-	dB
Saturated Output Power	Vd = 3.3 V Idq = 40mA	0	10	-	15	-	dBm
Small Signal Gain	Vd = 3.3 V Idq = 40mA Pin = -20 dBm	0	10	-	15.5	-	dB

Typical Performance Plots

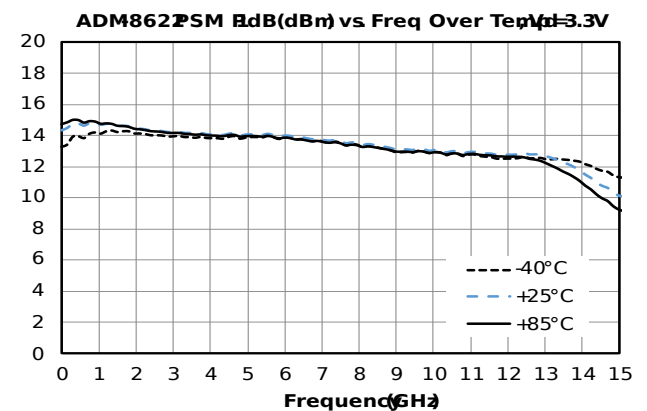
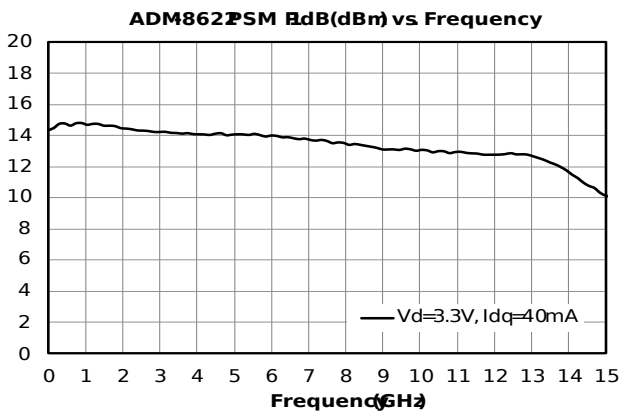
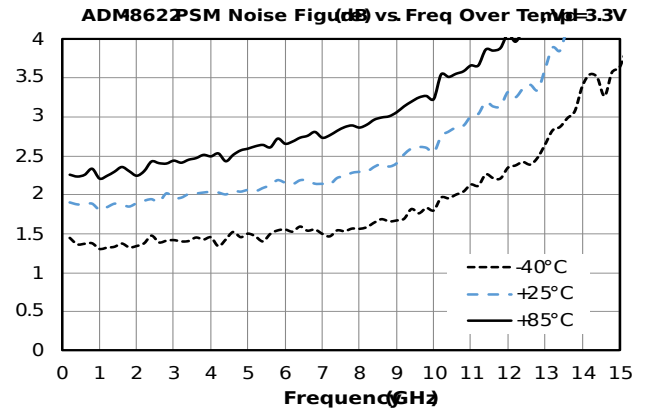
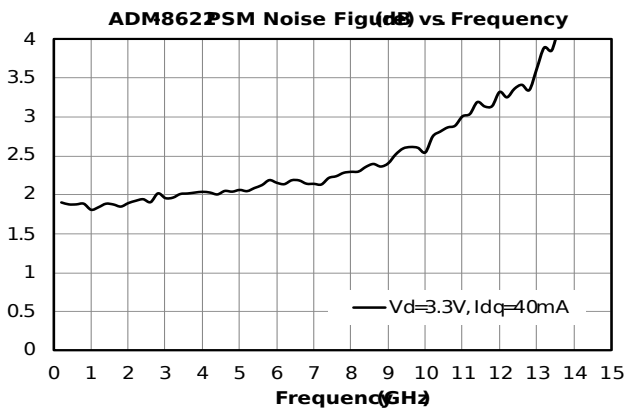
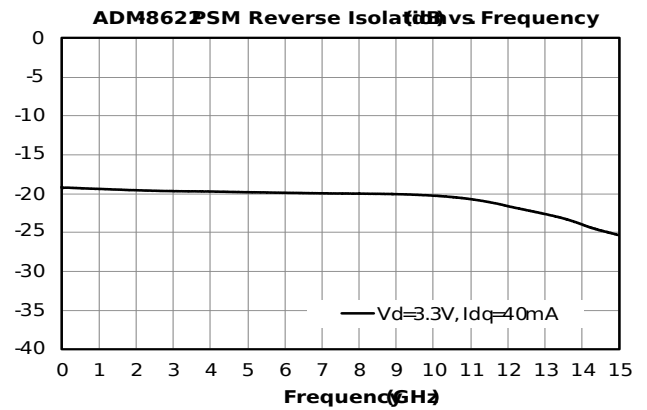
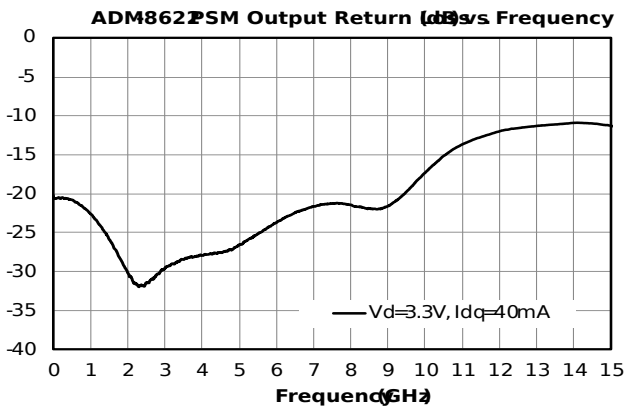
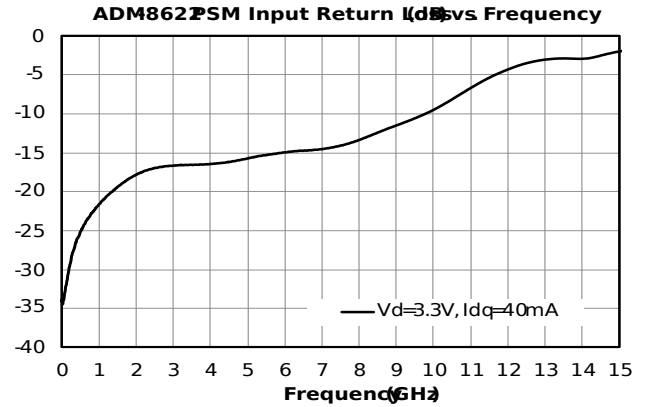
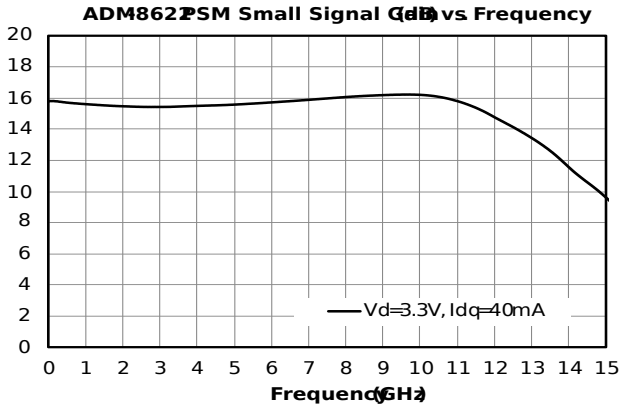

ADM-8622PSM

DC - 10 GHz High Dynamic Range Gain Block

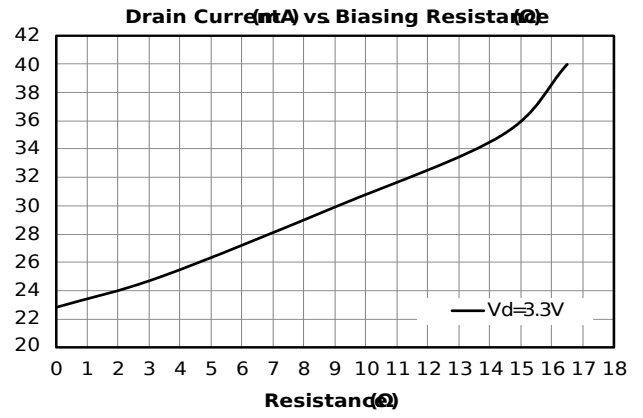
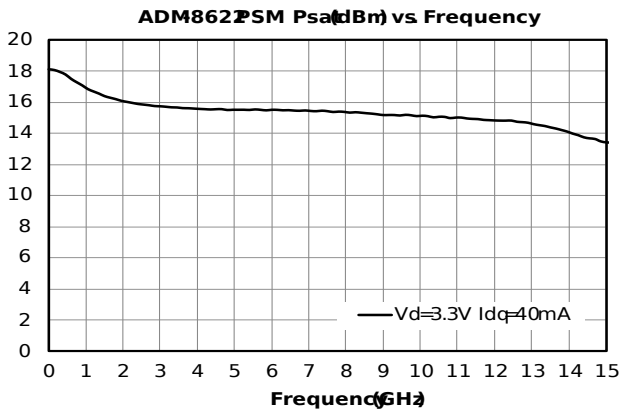

Application Information

Below is the recommended application circuit for the ADM-8622PSM.

Application Circuit

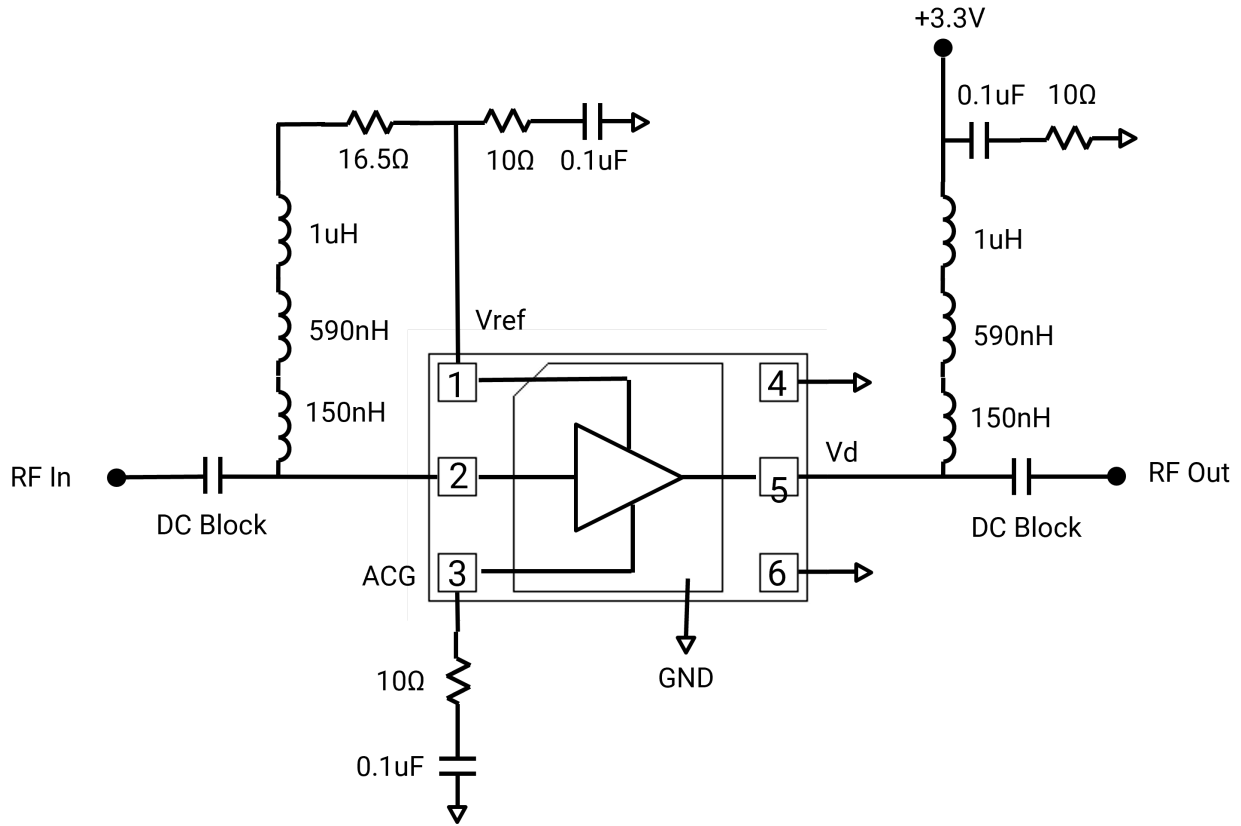

Application Circuit Description

Pin 1 (Vref) must be connected to Pin 2 (RF In) through external RF choke inductors. A resistor in series with the RF chokes will adjust the reference voltage to provide the correct drain current for low-resistance inductors. If the DC resistance of the RF chokes is significant, the voltage adjusting resistor must be lowered to maintain the correct drain current.

DC blocking capacitors are required outside of the choke inductors at the input and output. The low frequency response of the amplifier will be dominated by the choice of these blocking capacitors along with the RF choke inductors. In general, for very low frequencies of operation, high value inductors and capacitors will be required.

The ACG pin is connected to an internal gate bias node and should not be connected directly to GND. External bypassing should be applied on this line as shown.

Package ground paddle and unused pins 4 and 6 must be connected to a DC/RF ground potential with high thermal and electrical conductivity.

Mechanical Data

Outline Drawing

Download : [Outline 3D Drawing](#) | [Outline 3D STP](#)

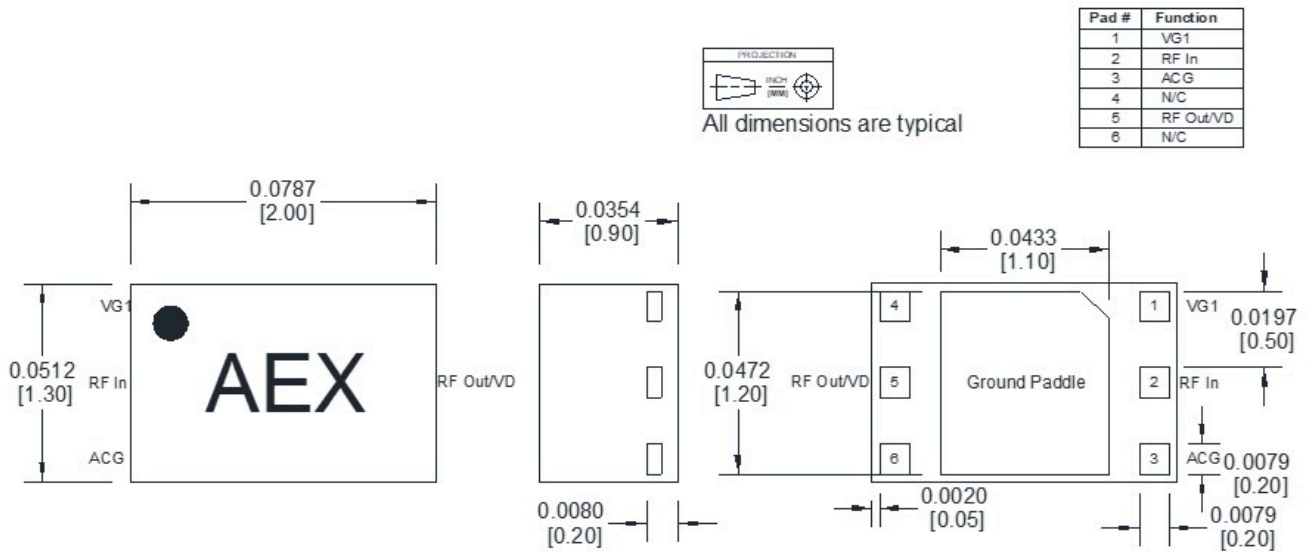

- 1) Substrate material is LCP
- 2) I/O Leads and Die Paddle is (from base to finish):
 - a. Ni: 0.5 um MIN
 - b. Pd: 0.02 um MIN
 - c. Au: 0.05 um MAX
- 3) All unconnected pins should be attached to PCB RF ground.

Footprint Image

Download : [Footprint Drawing](#)

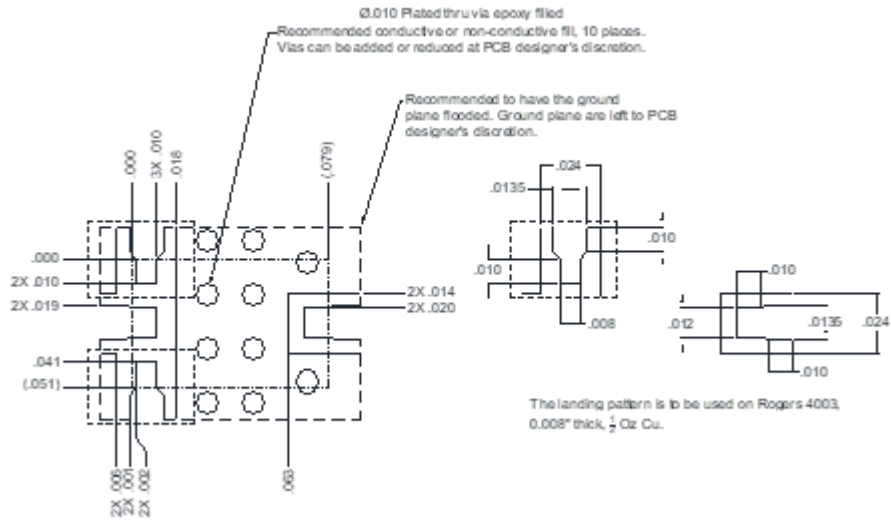

Evaluation Board - Typical Performance Plots

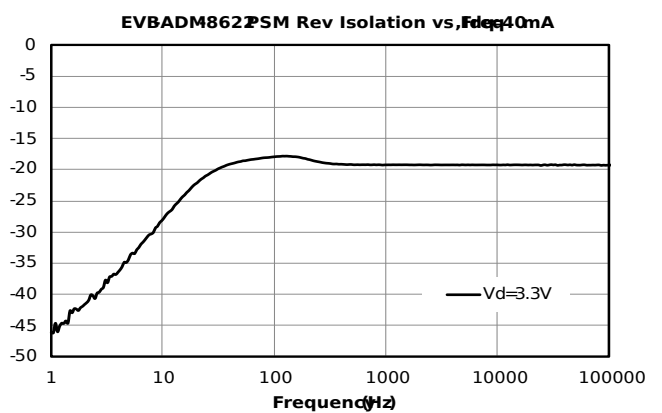
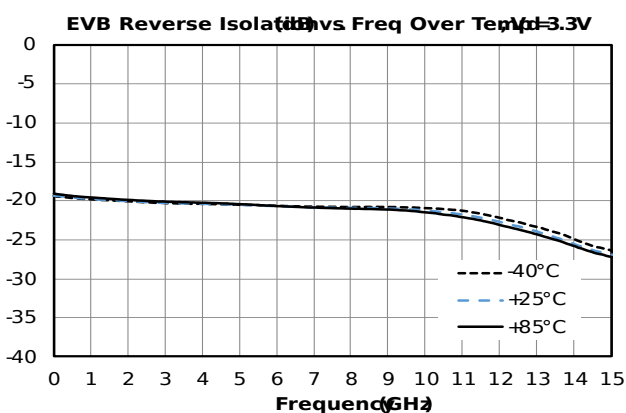
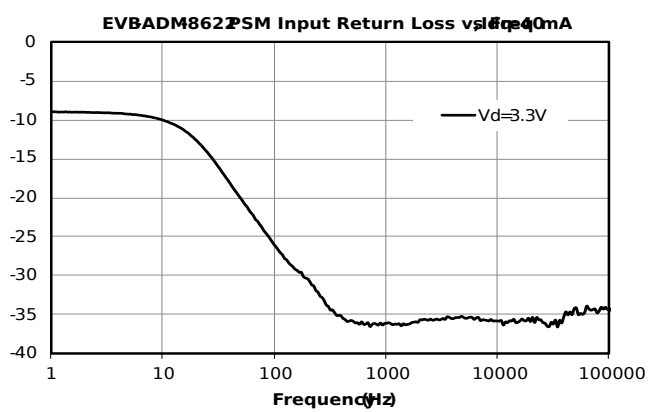
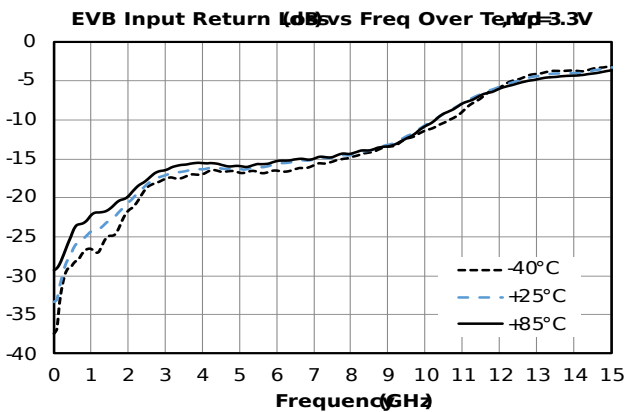
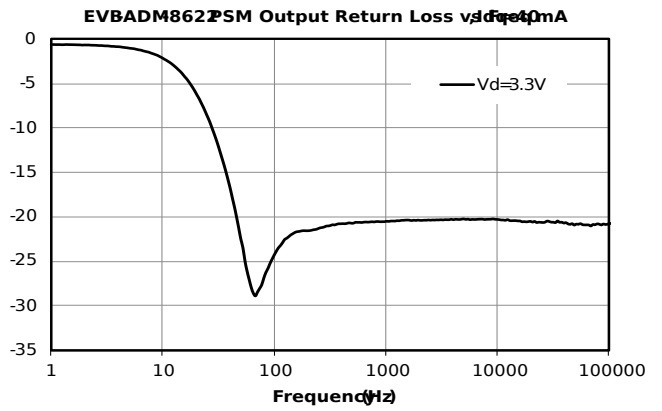
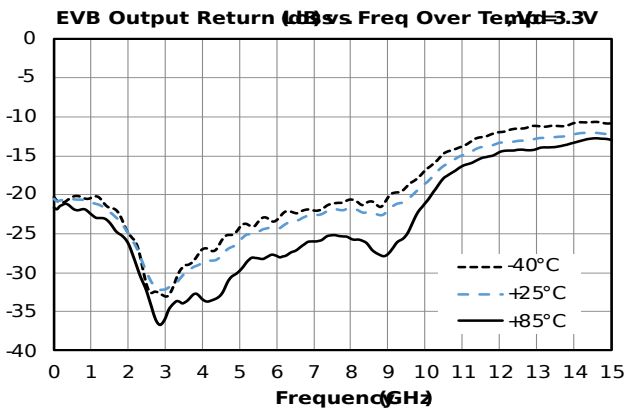
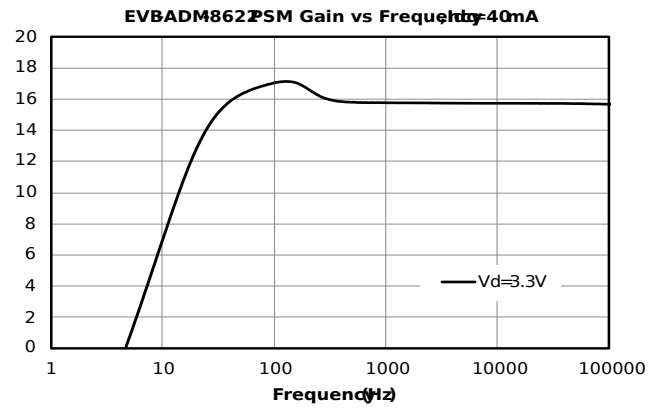
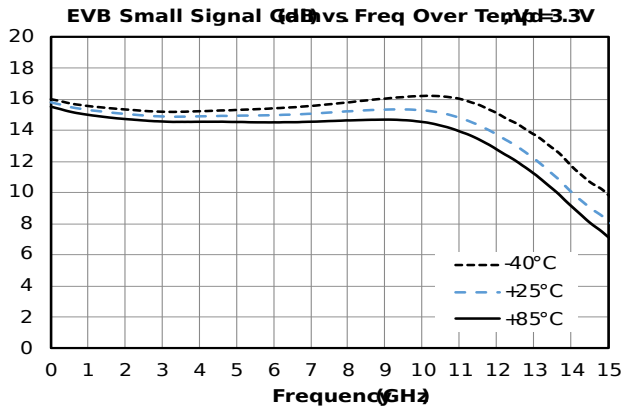

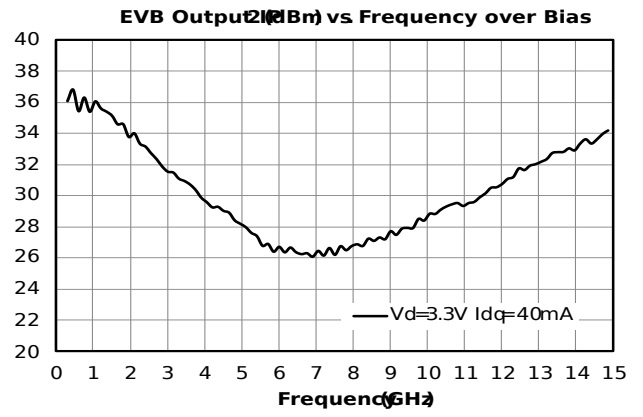
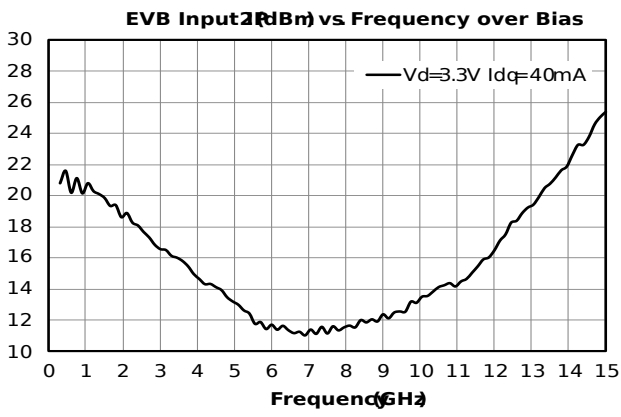
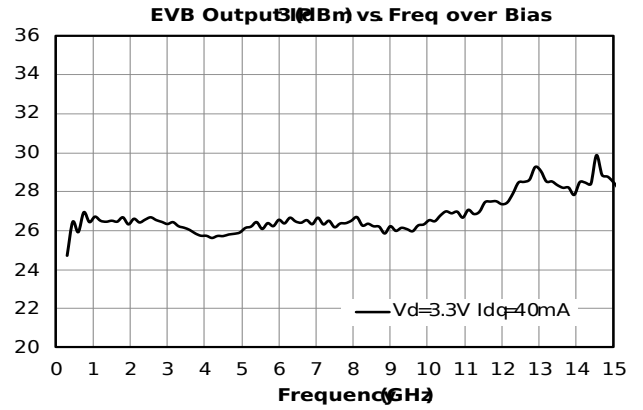
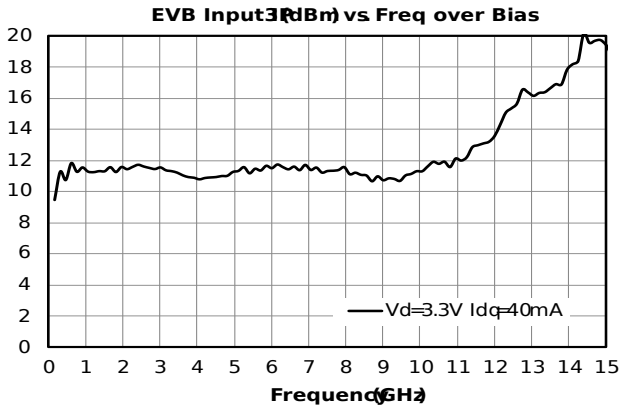

Evaluation Board - Outline Drawing

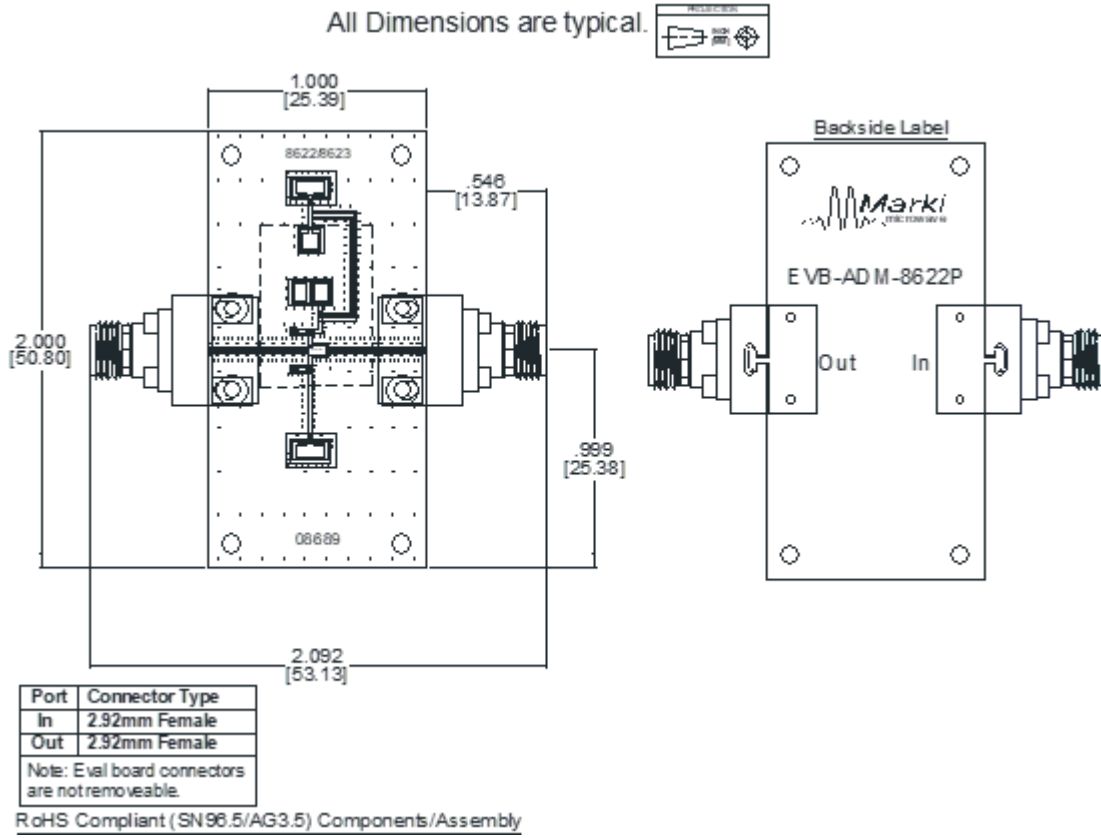

DISCLAIMER

MARKI MICROWAVE, LLC., ("MARKI") PROVIDES TECHNICAL SPECIFICATIONS AND DATA (INCLUDING DATASHEETS), APPLICATION OR OTHER DESIGN ADVICE, WEB TOOLS, AND OTHER INFORMATION AND RESOURCES "AS IS" AND WITH ALL FAULTS. MARKI DISCLAIMS ALL WARRANTIES, EXPRESS OR IMPLIED, INCLUDING, WITHOUT LIMITATION, ANY IMPLIED WARRANTIES OF MERCHANTABILITY, FITNESS FOR A PARTICULAR PURPOSE, OR NON-INFRINGEMENT.

These resources are intended for developers skilled in the art designing with Marki products. You are solely responsible for (1) selecting the appropriate products for your application, (2) designing, validating, and testing your application, and (3) ensuring your application meets applicable standards and other requirements. Marki makes no guarantee regarding the suitability of its products for any particular purpose, nor does Marki assume any liability whatsoever arising out of your use or application of any Marki product.

Marki grants you permission to use these resources only for development of an application that uses Marki products. Other reproduction or use of these resources is strictly prohibited. No license is granted to any other Marki intellectual property or to any third-party intellectual property. Marki reserves the right to make changes to the product(s) or information contained herein without notice.

MARKI MICROWAVE and T3 MIXER are trademarks or registered trademarks of Marki Microwave, LLC. All other trademarks used are the property of their respective owners.

© 2023, 2025, Marki Microwave, LLC