

MM1-1850SSM-2

GaAs MMIC Double Balanced Mixer

DEVICE OVERVIEW

General Description

The MM1-1850SSM is a GaAs MMIC double balanced mixer that operates at high frequency in a proprietary surface mount package. MM1-1850SSM is a K/Ka band mixer that works well as both an up and down converter. This mixer offers exceptionally high frequency RF bandwidth for a surface mount mixer and high spurious suppression. The sister MM1-1850HSM is recommended for lower LO power applications. The MM1-1850SSM is available in a proprietary 4x4 mm package. Evaluation boards are available.

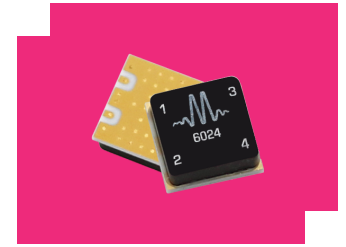

Features

- High Linearity
- High Frequency Operation
- RoHS Compliant

Applications

- Electronic Warfare Scanners
- 5G Test Receivers

Functional Block Diagram

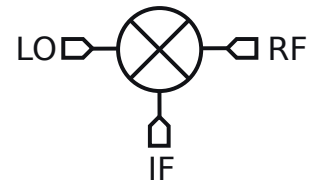

Part Ordering Options

Part Number	Description	Package	Green Status	Product Lifecycle	Export Classification
MM1-1850SSM-2	GaAs MMIC Double Balanced Mixer	KFN	REACH RoHS	Released	EAR99
EVAL-MM1-1850S	Evaluation Board, GaAs MMIC 18 - 50 GHz Double-balanced Mixer	EVAL	REACH RoHS	Released	EAR99

Table Of Contents

- **Device Overview**
 - General Description
 - Features
 - Applications
 - Functional Block Diagram
- **Port Configuration and Functions**
 - Port Diagram
 - Port Functions
- **Revision History**
- **Specifications**
 - Absolute Maximum Ratings
 - Package Information
 - Recommended Operating Conditions
 - Sequencing Requirements
 - Electrical Specifications
 - Typical Performance Plots
 - Typical Performance Plots: IP3
 - Typical Performance Plots: Spurious Suppression
 - Typical Performance Plots: Tuner Mixer
 - Spur Tables
- **Operation**
 - Application Circuit
 - Application Circuit Description
- **Mechanical Data**
 - Outline Drawing
- **Footprint Image**
- **Evaluation Board**

Revision History

Revision Code	Revision Date	Comment
-	2019-05-01	Datasheet Release
A	2019-07-01	Corrected SM Package Dimension Callout

Port Configuration and Functions

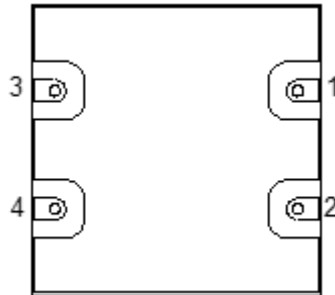

Port Diagram

A bottom-up view of the MM1-1850SSM's KFN package outline drawing is shown below. The MM1-1850SSM has the input and output ports given in Port Functions. The MM1-1850SSM can be used in either an up or down conversion. For configuration A, input the LO into pin 1, use pin 3 for the RF, and pin 2 for the IF. For configuration B, input the LO into pin 3, use pin 1 for the RF, and pin 2 for the IF.



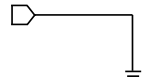
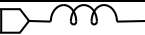

Port Functions

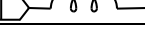
Configuration A

Port	Function	Description	Equivalent Circuit for Package
GND	Ground	KFN package ground path is provided through the ground paddle.	
Pin 1	LO	Pin 1 is DC open and AC matched to 50 Ohms from 18 to 50 GHz.	
Pin 2	IF	Port 2 is DC coupled to the diodes. Blocking capacitor is optional.	
Pin 3	RF	Pin 3 is DC open and AC matched to 50 Ohms from 18 to 50 GHz	
Pin 4	NC	Pin 4 is not connected internally and should be connected to RF ground.	-

Configuration B

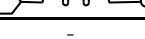
Port	Function	Description	Equivalent Circuit for Package
GND	Ground	KFN package ground path is provided through the ground paddle.	
Pin 1	RF	Pin 1 is DC open and AC matched to 50 Ohms from 18 to 50 GHz.	
Pin 2	IF	Port 2 is DC coupled to the diodes. Blocking capacitor is optional.	
Pin 3	LO	Pin 3 is DC open and AC matched to 50 Ohms from 18 to 50 GHz	
Pin 4	NC	Pin 4 is not connected internally and should be connected to RF ground.	-

Specifications

Absolute Maximum Ratings

The Absolute Maximum Ratings indicate limits beyond which damage may occur to the device. If these limits are exceeded, the device may be inoperable or have a reduced lifetime.

Parameter	Maximum Rating	Unit
Power Handling, at any Port	30	dBm

Package Information

Parameter	Details	Rating
ESD	250 to < 500 Volts	HBM Class 1A
Dimensions	-	4 x 4 mm
Moisture Sensitivity Level	-	MSL 1

Recommended Operating Conditions

The Recommended Operating Conditions indicate the limits, inside which the device should be operated, to guarantee the performance given in Electrical Specifications. Operating outside these limits may not necessarily cause damage to the device, but the performance may degrade outside the limits of the electrical specifications. For limits, above which damage may occur, see Absolute Maximum Ratings.

Parameter	Min	Nominal	Max	Unit
LO Input Power	20	-	28	dBm
Ambient Temperature	-	25	-	°C

Sequencing Requirements

There is no requirement to apply power to the ports in a specific order. However, it is recommended to provide a 50Ω termination to each port before applying power. This is a passive diode mixer that requires no DC bias.

Electrical Specifications

The electrical specifications apply at TA=+25°C in a 50Ω system. Typical data shown is for a down conversion application with the LO driven with an AMM-6702UC with +10 dBm input power biased at +4/-0.4V. Specifications shown for configuration A. Configuration B may be suitable for conversions below 45 GHz.

Parameter	Port Configuration	Test Conditions	Min	Typ	Max	Unit
Conversion Loss	-	RF = 18 - 50 GHz LO = 18 - 45 GHz IF = 0.2 - 21 GHz	-	9.7	-	dB
Conversion Loss	-	RF = 18 - 50 GHz LO = 18 - 45 GHz IF = DC - 0.2 GHz	-	7.9	12	dB
IF Frequency Range	-	-	0	-	21	GHz
Input 1 dB Gain Compression Point (P1dB)	-	-	-	14	-	dBm
Input IP3	-	RF/LO = 18 - 45 GHz IF = DC - 0.2 GHz	-	28	-	dBm
Isolation, LO to IF	-	IF/LO = 18 - 50 GHz	-	-	26	dB
Isolation, LO to RF	-	RF/LO = 18 - 50 GHz	-	28	-	dB
Isolation, RF to IF	-	RF/IF = 18 - 50 GHz	-	25	-	dB
LO Frequency Range	-	-	18	45	-	GHz
Noise Figure	-	RF = 18 - 50 GHz LO = 18 - 45 GHz IF = DC - 0.2 GHz	-	9.7	-	dB
Output IP3	-	RF/LO = 18 - 45 GHz IF = DC - 0.2 GHz	-	25	-	dBm
RF Frequency Range	-	-	18	-	50	GHz

Tuner mixer performance plots are taken with the following test conditions and frequency plan:

Typical Performance Plots

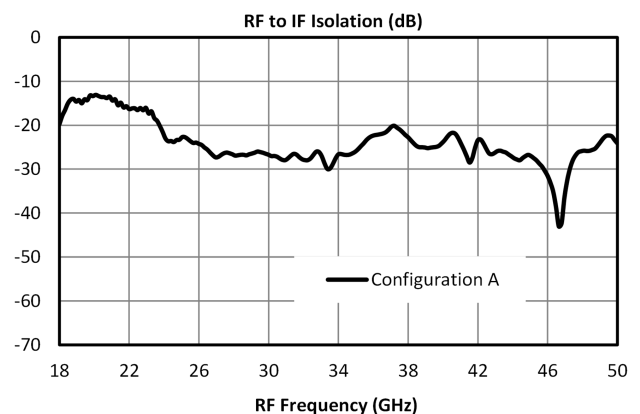
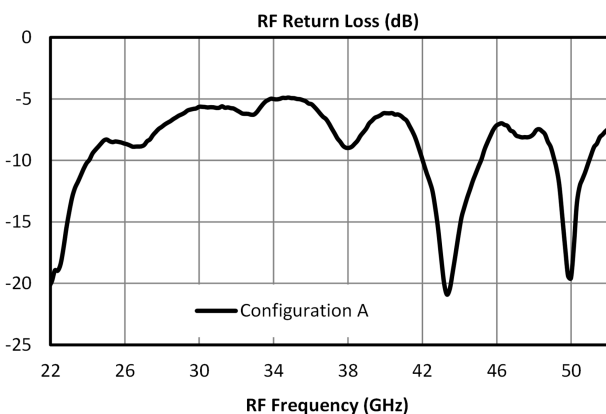
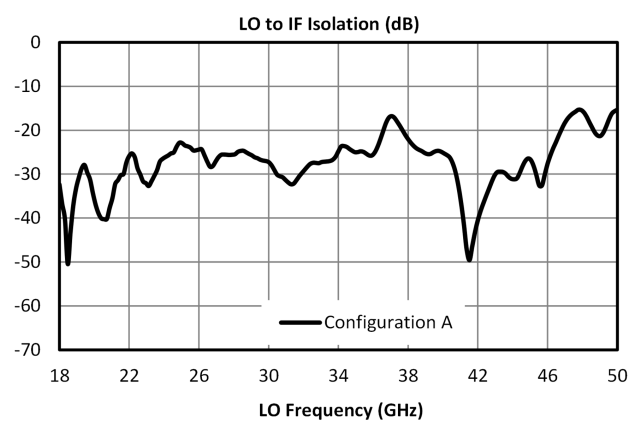
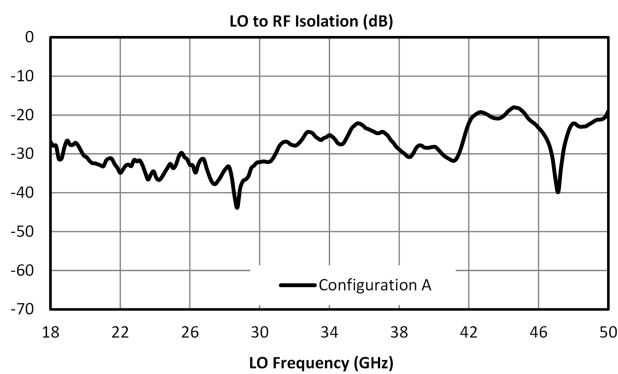
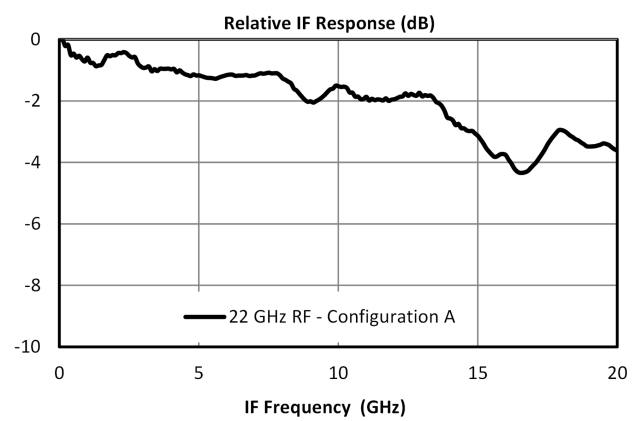
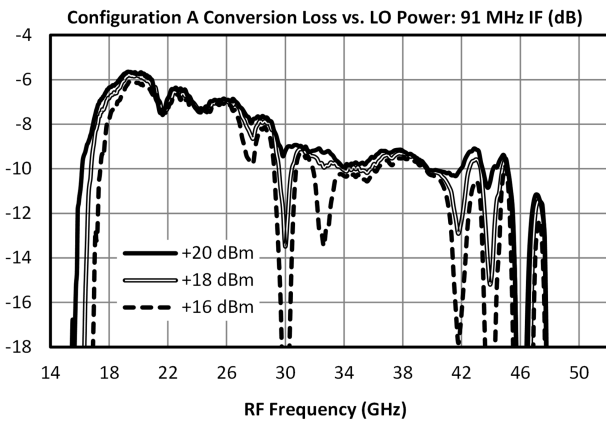
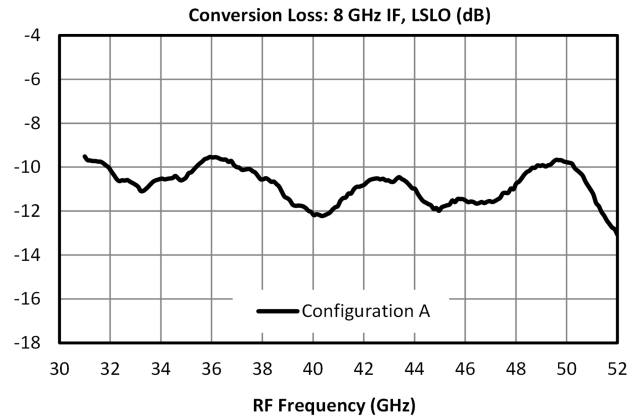
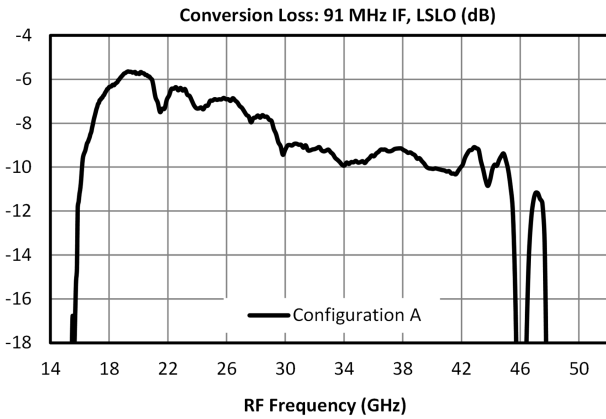

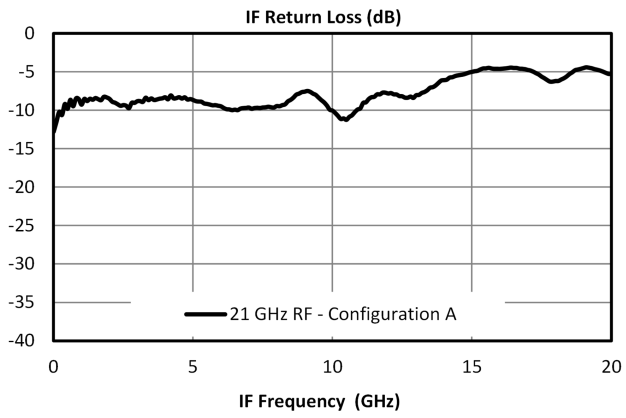

Typical Performance Plots: IP3

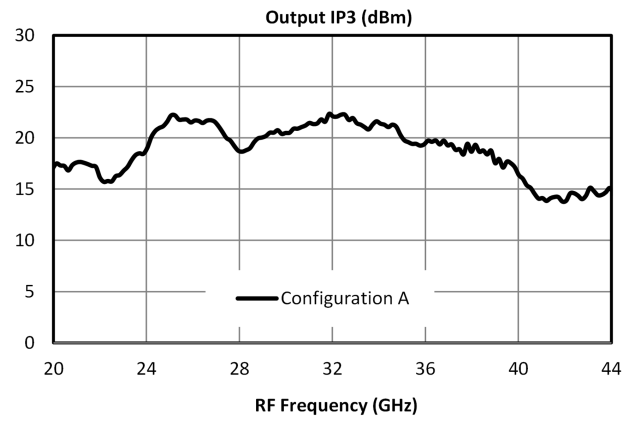
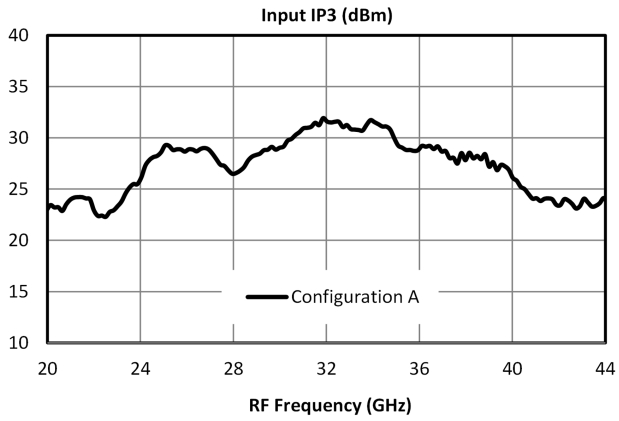

Typical Performance Plots: Spurious Suppression

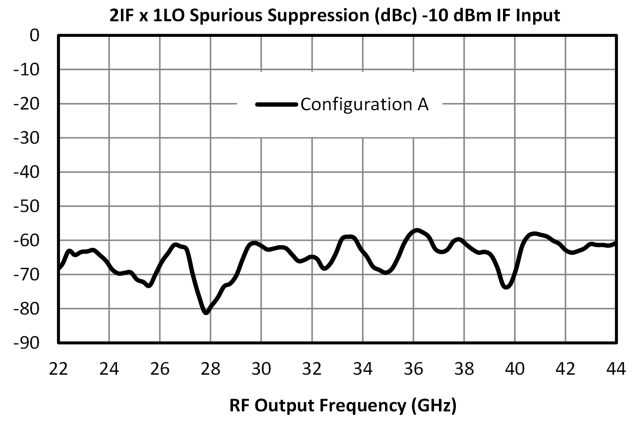
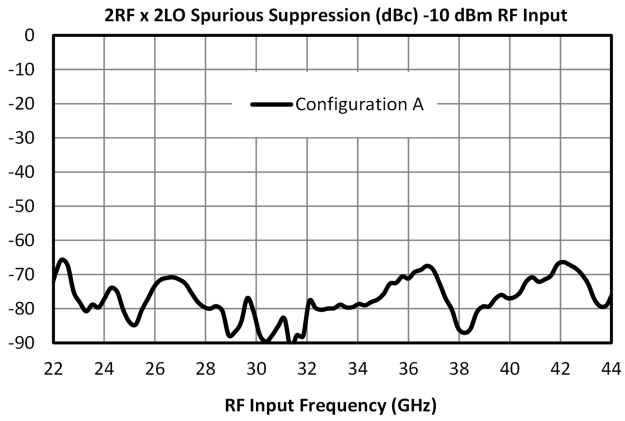

Typical Performance Plots: Tuner Mixer

Parameter	Start	Nominal	Stop	Units
IF Input Frequency	0		20	GHz
IF Input Power		-10		dBm
LO Input Frequency	22		42	GHz
RF Output Frequency		22		GHz

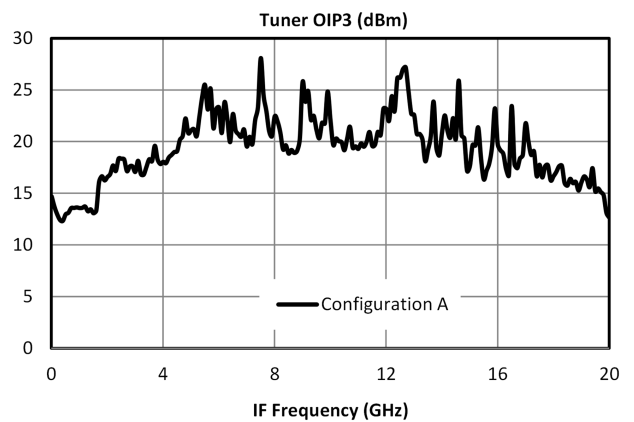
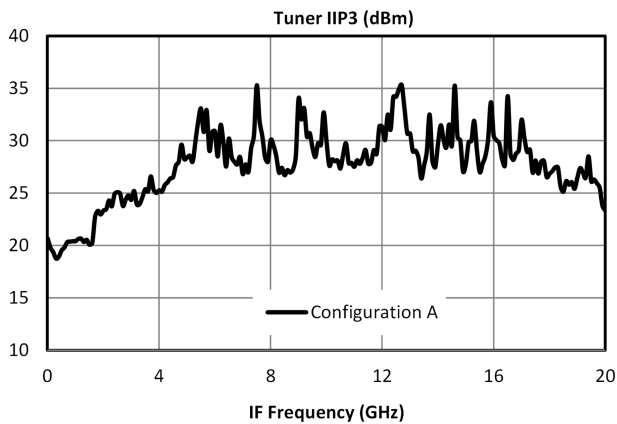
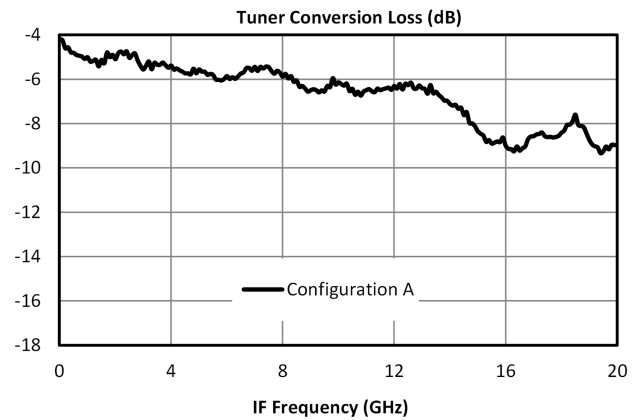
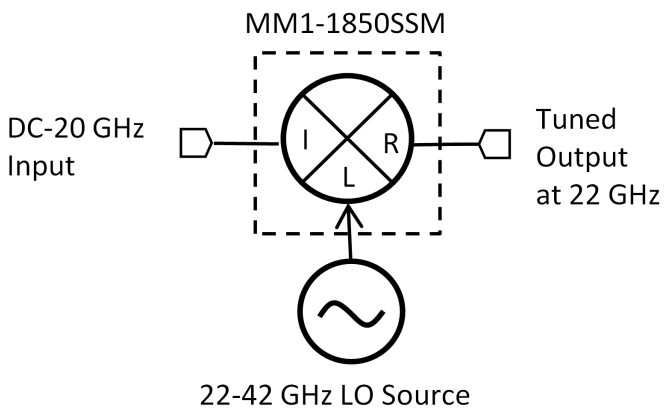

Spur Table

Typical Spurious Performance: Down-Conversion

Typical spurious data is provided by selecting RF and LO frequencies ($\pm m \cdot LO \pm n \cdot RF$) within the RF/LO bands, to create a spurious output within the IF band. The mixer is swept across the full spurious band and the mean is calculated. The numbers shown in the table below are for a -10 dBm RF input. Spurious suppression is scaled for different RF power levels by $(n-1)$, where “n” is the RF spur order. For example, the $2RF \times 2LO$ spur is 77 dBc for a -10 dBm input, so a -20 dBm RF input creates a spur that is $(2-1) \times (-10 \text{ dB})$ lower, or 87 dBc. Data is shown for the frequency plan in Typical Performance. $mLO \times 0RF$ plots can be found in section 3.6.2 Typical Performance Plots: $0LO \times 1RF$ plot is identical to the plot of LO-RF isolation.

Typical Down-conversion spurious suppression (dBc): Config A

-10 dBm RF Input	0xLO	1xLO	2xLO	3xLO	4xLO	5xLO
1xRF	27	Reference	25	15	NA	NA
2xRF	85	59	77	71	70	NA
3xRF	NA	70	87	86	93	90
4xRF	NA	NA	121	122	121	127
5xRF	NA	NA	NA	135	132	131

Typical Spurious Performance: Up-Conversion

Typical spurious data is taken by mixing an input within the IF band, with LO frequencies ($\pm m \cdot LO \pm n \cdot IF$), to create a spurious output within the RF output band. The mixer is swept across the full spurious output band and the mean is calculated. The numbers shown in the table below are for a -10 dBm IF input. Spurious suppression is scaled for different IF input power levels by $(n-1)$, where “n” is the IF spur order. For example, the $2IFx1LO$ spur is typically 64 dBc for a -10 dBm input with a sine-wave LO, so a -20 dBm IF input creates a spur that is $(2-1) \times (-10 \text{ dB})$ lower, or 74 dBc. Data is shown for the frequency plan in Typical Performance.

Typical Up-conversion spurious suppression (dBc): Config A

-10 dBm IF Input	0xLO	1xLO	2xLO	3xLO	4xLO	5xLO
1xIF	13	Reference	16	11	NA	NA
2xIF	56	64	59	63	71	NA
3xIF	79	78	72	74	76	70
4xIF	101	116	67	113	110	111
5xIF	116	126	119	124	121	122

Typical Spurious Performance: Tuner Mixer

The following spurs are present in a typical tuner mixer conversion application.

Typical Tuner Mixer spurious suppression (dBc): Config A

-10 dBm IF Input	-2xLO	-1xLO	0xLO	1xLO	2xLO	3xLO	4xLO
-5xIF	NA	NA	NA	NA	NA	NA	125
-4xIF	NA	NA	NA	112	114	118	115
-3xIF	NA	NA	NA	78	86	86	NA
-2xIF	NA	NA	NA	61	63	NA	NA
2xIF	NA	NA	53	NA	NA	NA	NA
3xIF	NA	85	86	NA	NA	NA	NA
4xIF	115	107	NA	NA	NA	NA	NA

Application Circuit

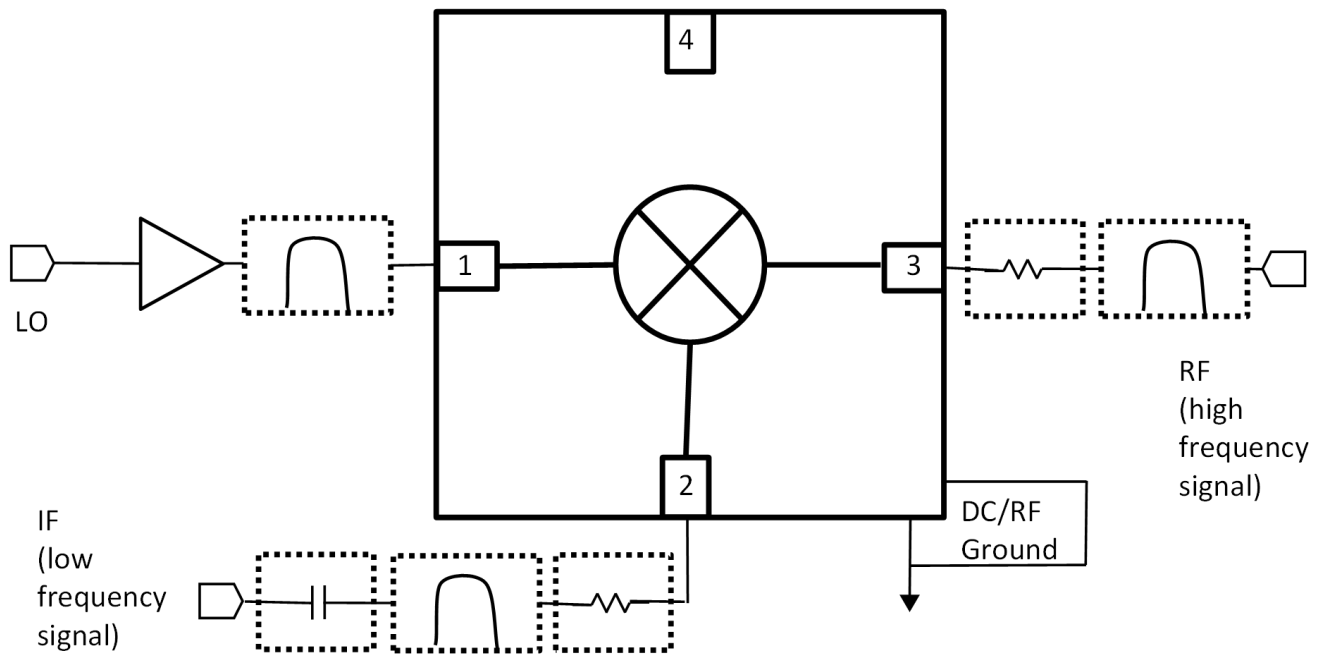

Configuration A

Application Circuit Description

IF Port – Used as input on an upconversion, output on downconversion, or LO port in a band shifting application. Signals should be connected by 50 ohm microstrip or coplanar traces to well matched broadband 50 ohm sources and loads. Blocking capacitor is recommended if DC voltage is present on the line.

RF Port – Used as input on a downconversion, output on upconversion, or output in a band shifting application. Signals should be connected by 50 ohm microstrip or coplanar traces to well matched broadband 50 ohm sources and loads.

Filtering and Matching- Filtering is generally desired for spurious and image removal on the output port of the mixer. Reflective filters can cause out of band signals to reflect back into the mixer and cause conversion loss ripple, erroneous spurs, and other undesired behaviors. To eliminate these problems it is recommend that the filters be placed as close to the output port as possible. If undesired behavior is still observed, a diplexer with one port terminated or a 1-3 dB attenuator may reduce this problem.

RF Ground – The ground paddle of the QFN should be connected to a low noise RF ground with very low electrical resistance for high frequency operation.

LO Port – The noise floor of the LO input signal should be less than the value of the noise floor plus isolation of the mixer, or a filter is recommended to prevent reduction in dynamic range. An LO amplifier is required if the LO power is below the recommended drive level. It is important to use an amplifier with a broadband 50 ohm match such that it does not reflect spurious signals back into the mixer or other system circuitry.

Mechanical Data

Outline Drawing

Download : [Outline 2D Drawing](#) | [Outline 3D Drawing](#) | [Outline 3D STP](#)

1	LO
2	IF
3	RF
4	N/C

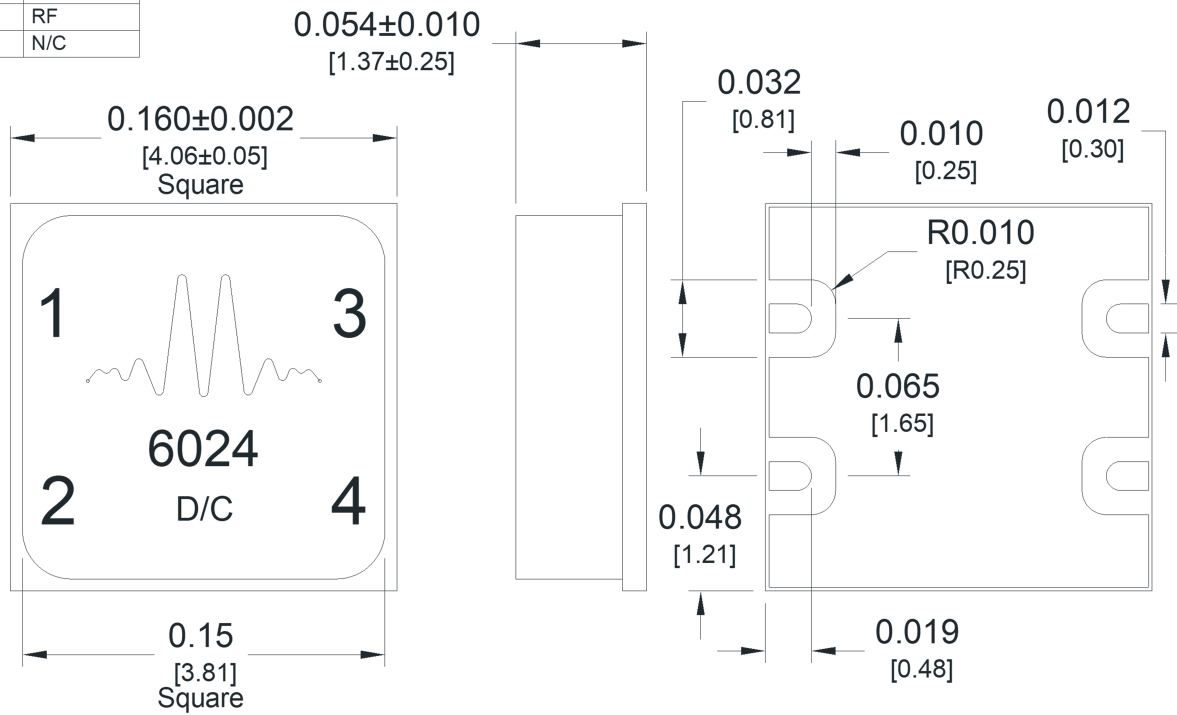

Notes (unless otherwise specified):

1. Substrate and lid material is Ceramic.
2. I/O Leads and Ground Paddle plating is 2 uin Au max over 40-80 uin Ni over 433 uin of Ag.
3. All unconnected pins should be connected to PCB RF ground.

Proprietary: This document was originated by and is the property of Marki Microwave. Unauthorized disclosure is prohibited.

I/O Leads and Ground Paddle plating is 2 uin Au max over 40-80 uin Ni over 433 uin of Ag.

Footprint Image

Download : [Footprint Drawing](#)

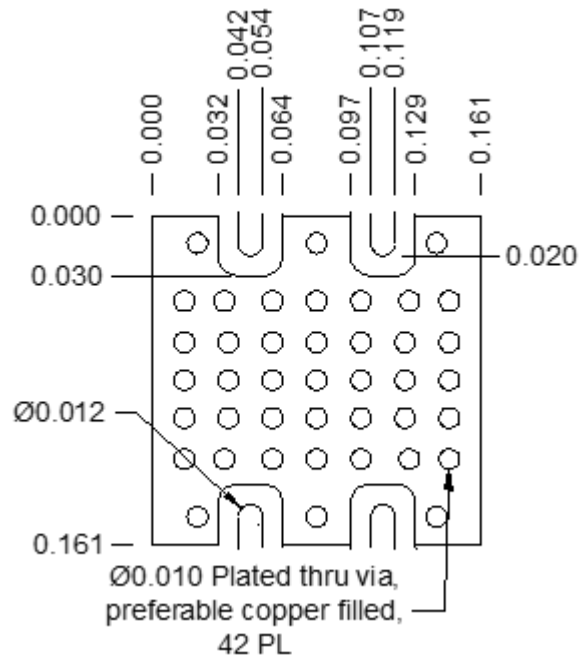

DISCLAIMER

MARKI MICROWAVE, INC., ("MARKI") PROVIDES TECHNICAL SPECIFICATIONS AND DATA (INCLUDING DATASHEETS), APPLICATION OR OTHER DESIGN ADVICE, WEB TOOLS, AND OTHER INFORMATION AND RESOURCES "AS IS" AND WITH ALL FAULTS. MARKI DISCLAIMS ALL WARRANTIES, EXPRESS OR IMPLIED, INCLUDING, WITHOUT LIMITATION, ANY IMPLIED WARRANTIES OF MERCHANTABILITY, FITNESS FOR A PARTICULAR PURPOSE, OR NON-INFRINGEMENT.

These resources are intended for developers skilled in the art designing with Marki products. You are solely responsible for (1) selecting the appropriate products for your application, (2) designing, validating, and testing your application, and (3) ensuring your application meets applicable standards and other requirements. Marki makes no guarantee regarding the suitability of its products for any particular purpose, nor does Marki assume any liability whatsoever arising out of your use or application of any Marki product.

Marki grants you permission to use these resources only for development of an application that uses Marki products. Other reproduction or use of these resources is strictly prohibited. No license is granted to any other Marki intellectual property or to any third-party intellectual property. Marki reserves the right to make changes to the product(s) or information contained herein without notice.

MARKI MICROWAVE and T3 MIXER are trademarks or registered trademarks of Marki Microwave, Inc. All other trademarks used are the property of their respective owners.

© 2019, Marki Microwave, Inc