

MMIQ-0205HXA

MMIC Double-Balanced I/Q Mixer

DEVICE OVERVIEW

General Description

The MMIQ-0205HSM is a miniaturized, surface-mount multi-octave 1.75-5.0 GHz IQ mixer. It features matched double balanced mixers connected with an integrated LO hybrid and RF power divider. It can be used for either upconversion or downconversion. Applications include communications or radar systems with advanced digital modulation formats and phase modulated signals, test and measurement, or electronic warfare. Image reject or single sideband modulation with excellent suppression is possible with use of an external IF quadrature (90°) hybrid.

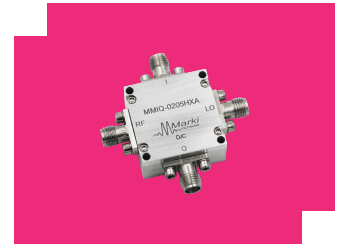

Features

- CAD Optimized for Superior Isolation, Spurious Response, and Image Rejection/Sideband Suppression
- Broadband Performance
- Excellent Unit-to-Unit Repeatability
- Fully nonlinear software models available with Marki Circuit Models for Microwave Office
- RoHS Compliant

Applications

N/A

Functional Block Diagram

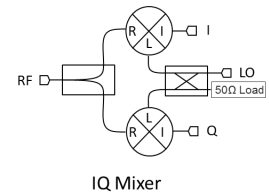

Part Ordering Options

Part Number	Description	Connectors	Green Status	Product Lifecycle	Export Classification
MMIQ-0205HXA	MMIC Double-Balanced I/Q Mixer	<u>Standard</u>	REACH RoHS	Released	EAR99

Table Of Contents

■ Device Overview

- General Description
- Features
- Applications
- Functional Block Diagram

■ Port Configuration and Functions

- Port Functions

■ Specifications

- Absolute Maximum Ratings
- Recommended Operating Conditions
- Electrical Specifications
- Typical Performance
- Spur Tables

■ Operation

- Application Information

■ Mechanical Data

- Outline Drawing

■ Evaluation Board

- Evaluation Board - Performance Data

Port Configuration and Functions

Port Functions

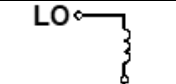
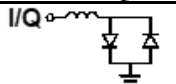
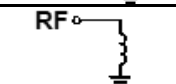
Port	Function	Connector Type	Description	DC Equivalent Circuit
Pin 12	Q	-	The I/Q ports are DC coupled to the diodes. Blocking capacitor is optional.	
Pin 22	LO	-	The LO port is DC open and AC matched to 50 Ohms from 1.75 to 5 GHz. Blocking capacitor is optional.	
Pin 29	I	-	The I/Q ports are DC coupled to the diodes. Blocking capacitor is optional.	
Pin 4	RF	-	The RF port is DC short to ground and AC matched to 50 Ohms from 1.75 to 5 GHz. Blocking capacitor is optional.	

Specifications

Absolute Maximum Ratings

Parameter	Maximum Rating	Unit
DC Current ¹	30	mA
DC Current ²	30	mA
DC Current	30	mA
Maximum Operating Temperature	100	°C
Maximum Storage Temperature	125	°C
Minimum Operating Temperature	-55	°C
Minimum Storage Temperature	-65	°C
RF Power Handling (RF+LO), 100°C	23	dBm
RF Power Handling (RF+LO), 25°C	26	dBm

^{[1][2]} Application of DC current has been known to damage mixer diodes. Any application of DC current >30 mA could cause field damage and void the warranty.

Recommended Operating Conditions

Parameter	Min	Nominal	Max	Unit
LO Input Power	14	-	20	-

Electrical Specifications

Specifications guaranteed from -55 to +100°C, measured in a 50Ω system.

Parameter	Test Conditions	Minimum Frequency (GHz)	Maximum Frequency (GHz)	Min	Typ	Max	Unit
Conversion Loss ¹	LO=RF=1.75-5 GHz, IF=DC-2.0 GHz	1.75	5	-	8	10.5	dB
Image Rejection	-	-	-	-	33	-	dBc
Input IP3 ²	LO=RF=1.75-5 GHz, IF=DC-2.0 GHz	1.75	5	-	20	-	dBm
Input P1dB ³	LO=RF=1.75-5 GHz, IF=DC-2.0 GHz	1.75	5	-	12	-	dBm
I/Q Amplitude Balance	LO=RF=1.75-5 GHz, IF=DC-2.0 GHz	1.75	5	-	0.16	-	dB
Phase Balance	LO=RF=1.75-5 GHz, IF=DC-2.0 GHz	1.75	5	-	3	-	°
IF Frequency Range	-	-	-	0	-	2	GHz
Isolation, LO to RF	-	-	-	-	60	-	dB
LO Frequency Range	-	-	-	1.75	-	5	GHz
RF Frequency Range	-	-	-	1.75	-	5	GHz

[1][2][3] Combined IF with Test Hybrid

Typical Performance

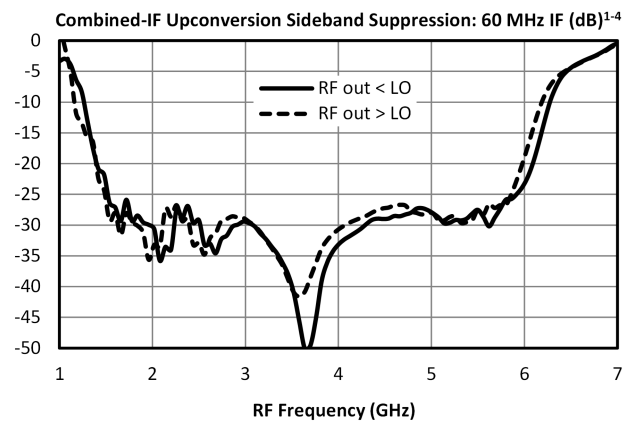
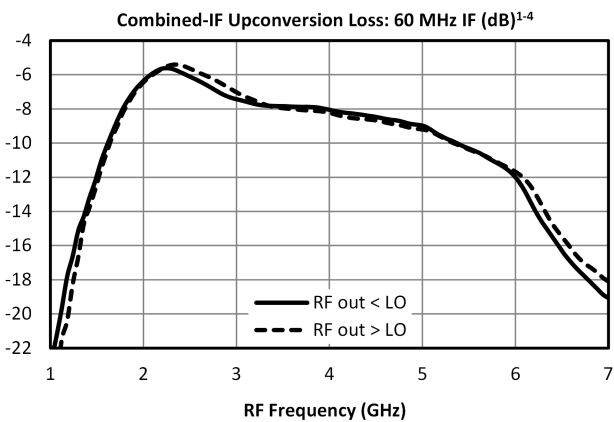
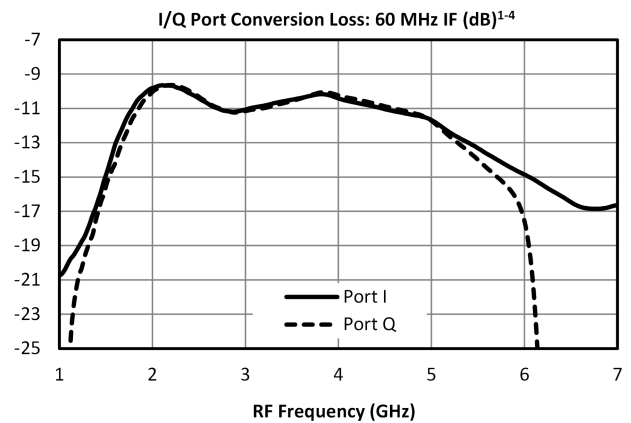
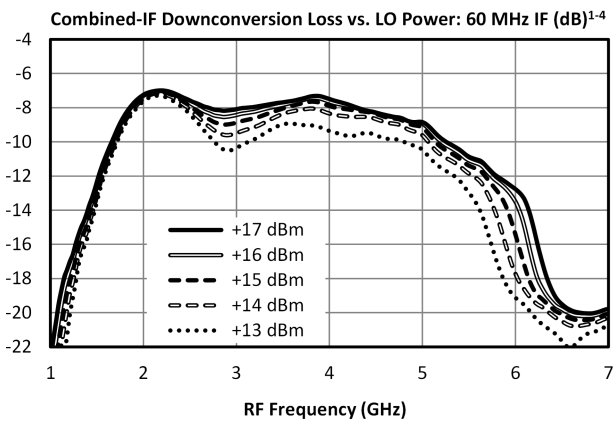
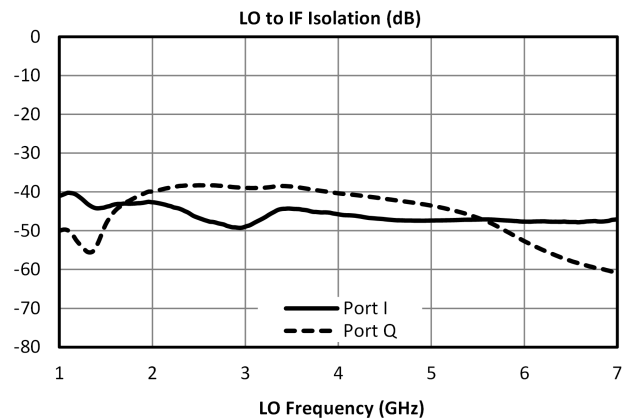
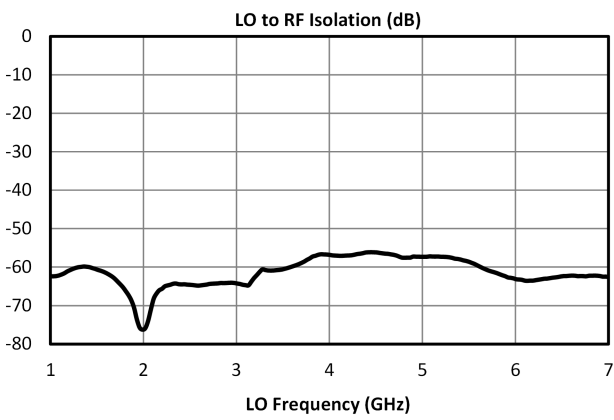
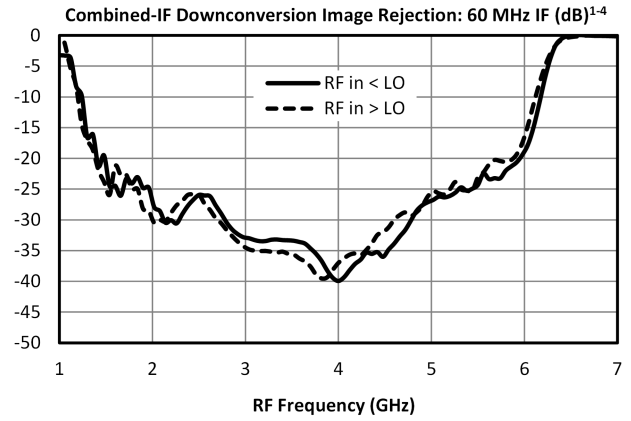
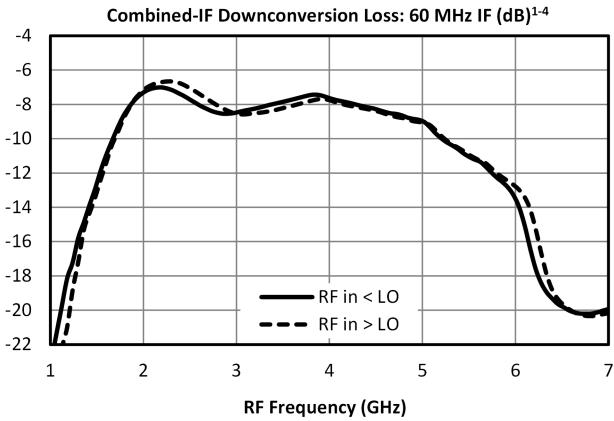

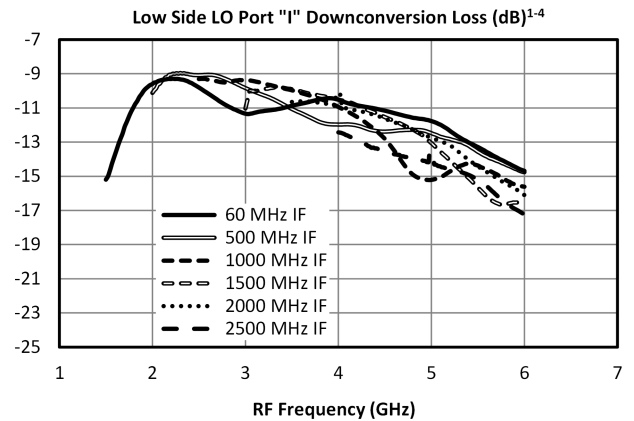
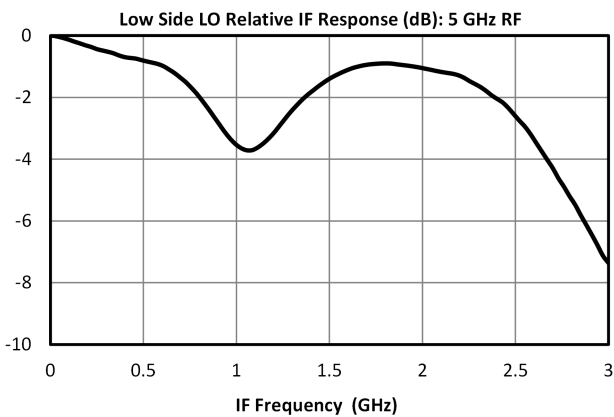
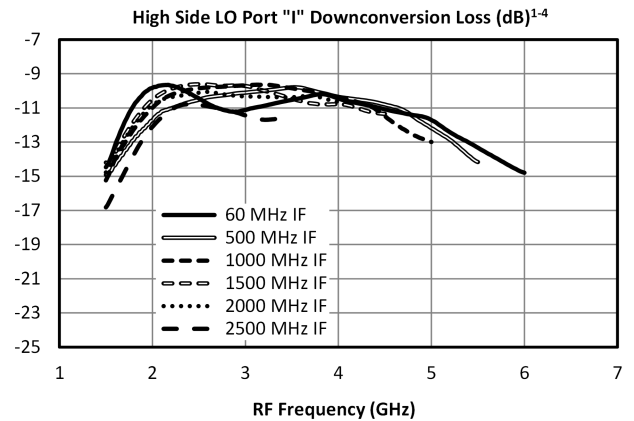
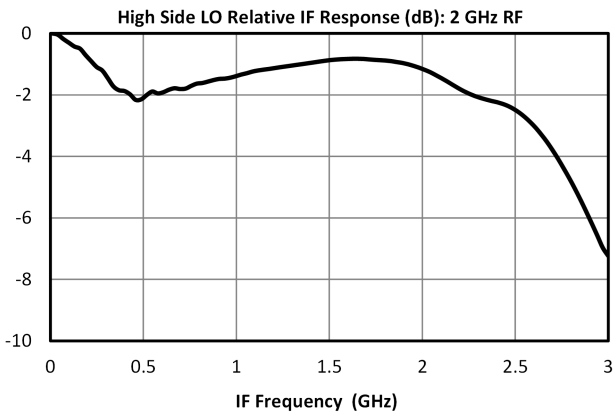
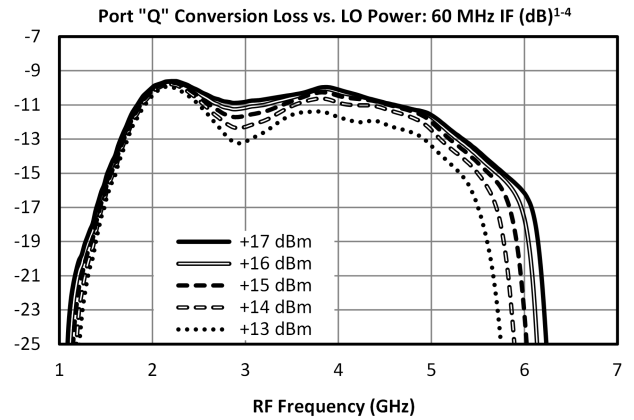
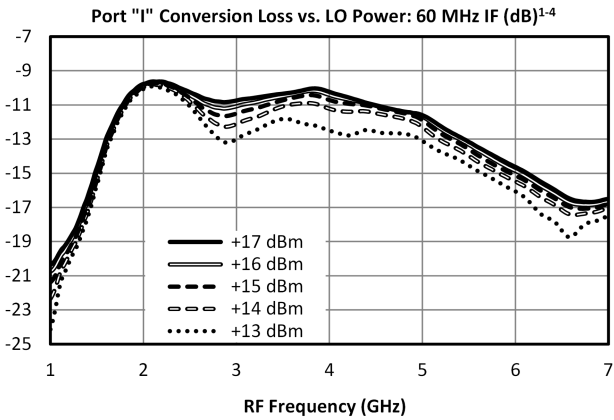
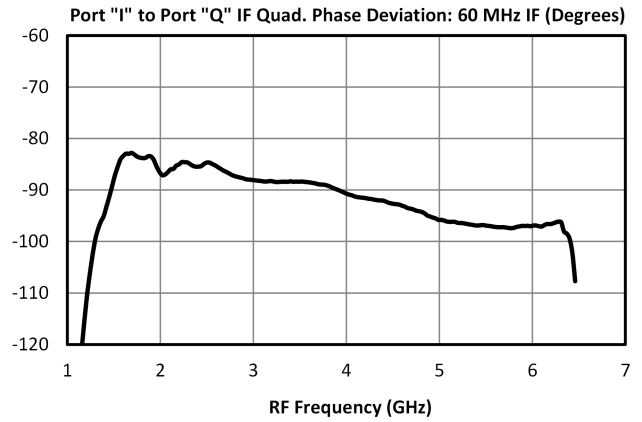
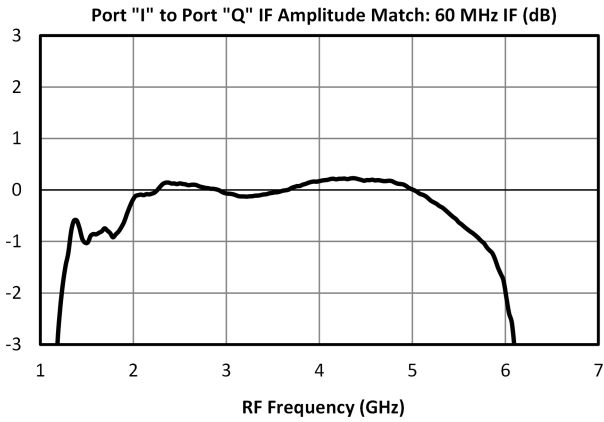

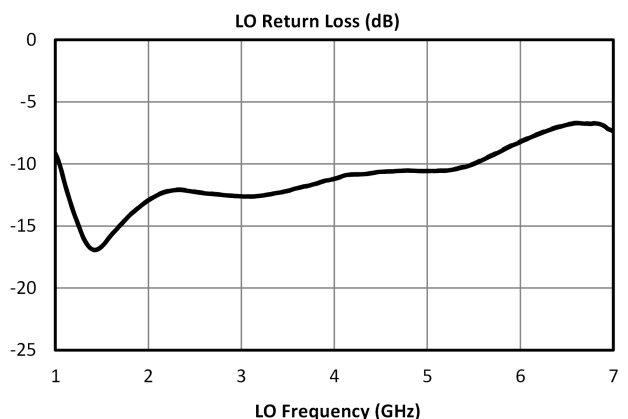
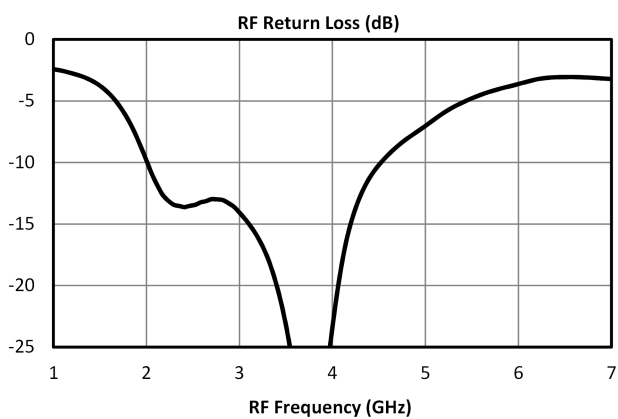
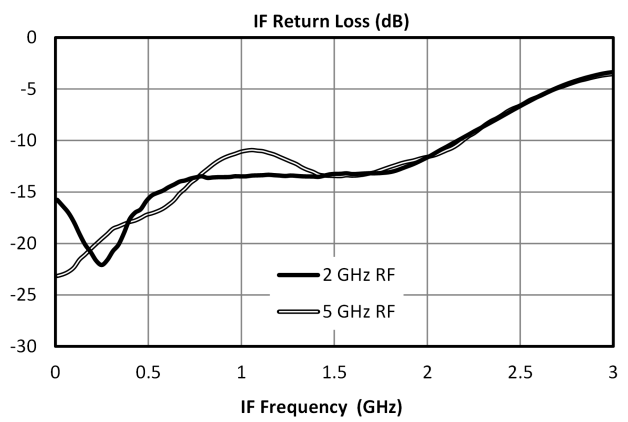
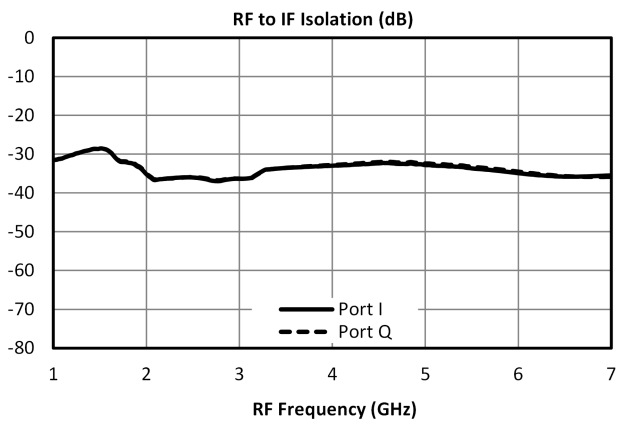
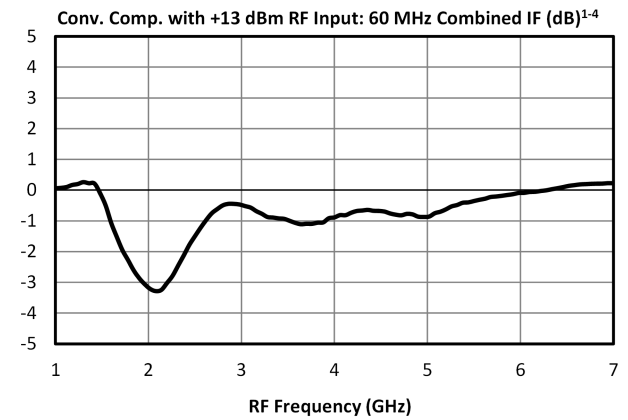
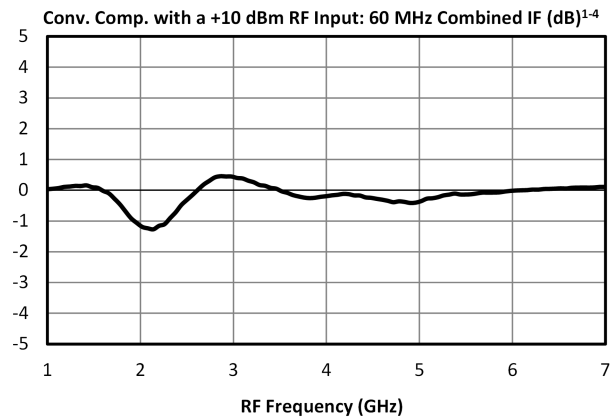
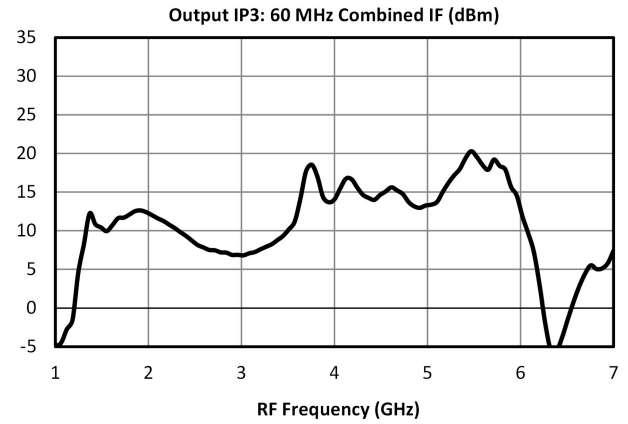
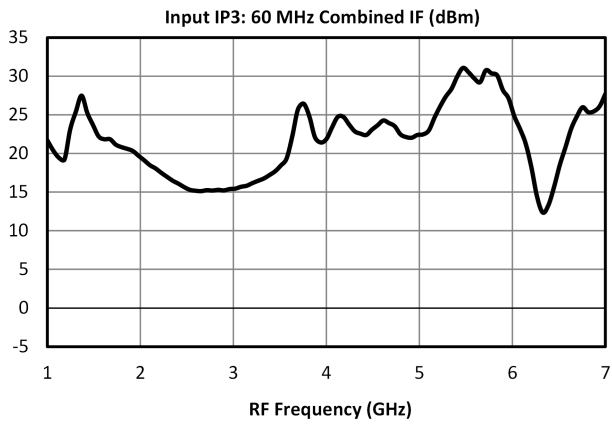

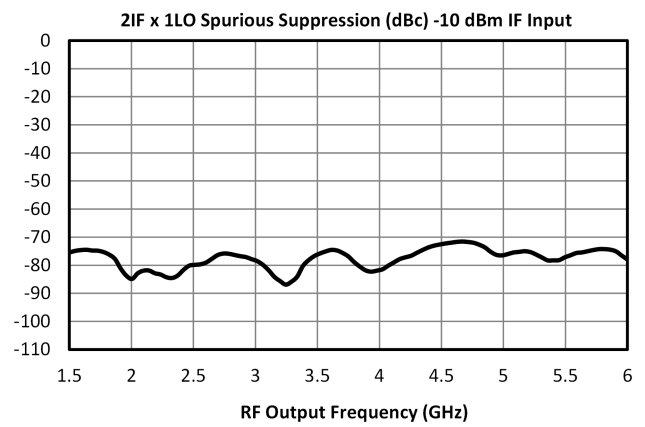
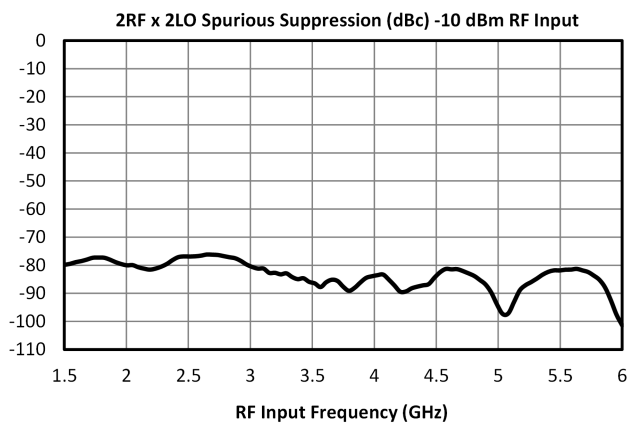
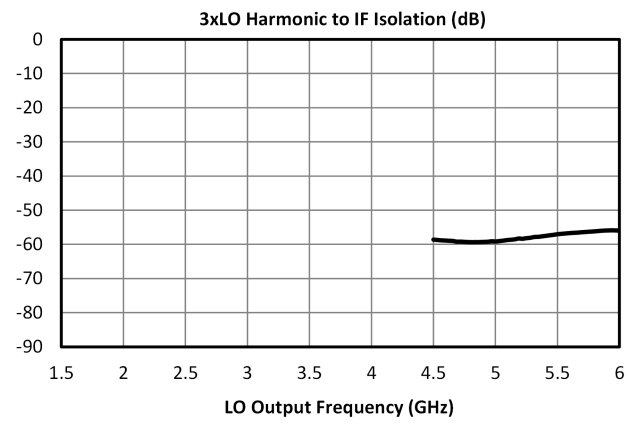
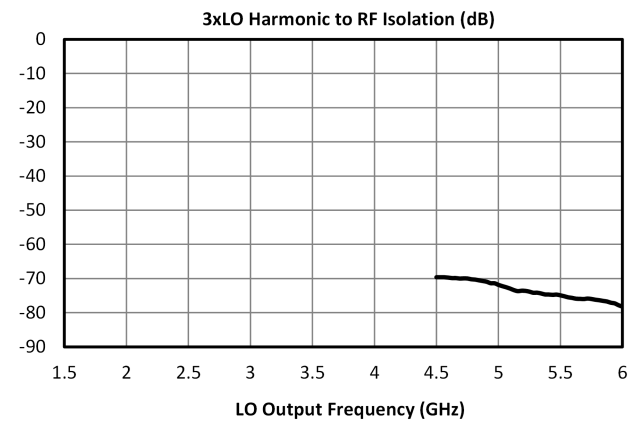
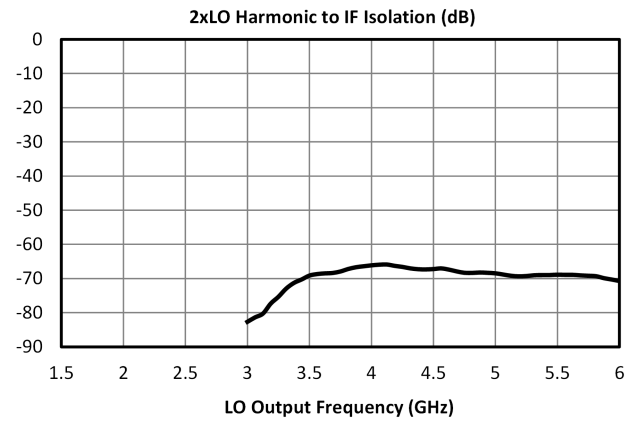
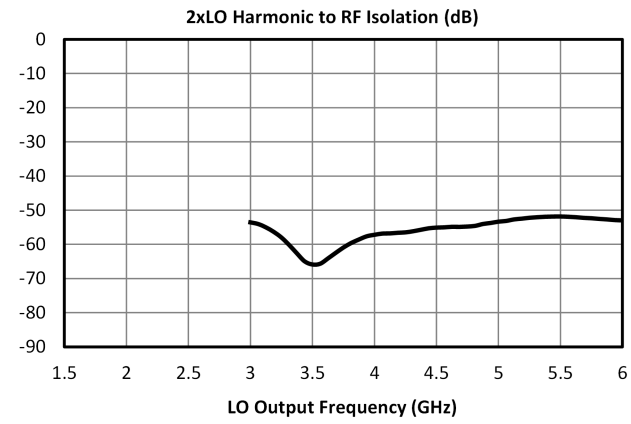

Spur Table

Downconversion Spurious Suppression

Spurious data is taken by selecting RF and LO frequencies (+mLO+nRF) within the RF/LO bands, to create a spurious output within the IF band. The mixer is swept across the full spurious band and the mean is calculated. The numbers shown in the table below are for a -10 dBm RF input. Spurious suppression is scaled for different RF power levels by (n-1), where “n” is the RF spur order. For example, the 2RFx2LO spur is 83 dBc for a -10 dBm input, so a -20 dBm RF input creates a spur that is (2-1) x (-10 dB) dB lower, or 93 dBc.

Typical Downconversion Spurious Suppression (dBc) ⁴

-10 dBm RF Input	0xLO	1xLO	2xLO	3xLO	4xLO	5xLO
1xRF	23	Reference	42	15	55	18
2xRF	91	63	83	64	78	67
3xRF	92	76	88	68	94	68
4xRF	142	110	118	109	119	103
5xRF	155	126	134	121	129	115

Upconversion Spurious Suppression

Spurious data is taken by mixing an input within the IF band, with LO frequencies (+mLO+nIF), to create a spurious output within the RF output band. The mixer is swept across the full spurious output band and the mean is calculated. The numbers shown in the table below are for a -10 dBm IF input. Spurious suppression is scaled for different IF input power levels by (n-1), where “n” is the IF spur order. For example, the 2IFx1LO spur is typically 78 dBc for the A configuration for a -10 dBm input, so a -20 dBm IF input creates a spur that is (2-1) x (-10 dB) dB lower, or 88 dBc.

Typical Upconversion Spurious Suppression (dBc)⁴

-10 dBm IF Input	0xLO	1xLO	2xLO	3xLO	4xLO	5xLO
1xIF	23	Reference	39	9	51	33
2xIF	59	78	59	84	59	81
3xIF	92	58	84	54	84	60
4xIF	107	124	97	120	101	120
5xIF	135	103	127	106	123	103

Application Information

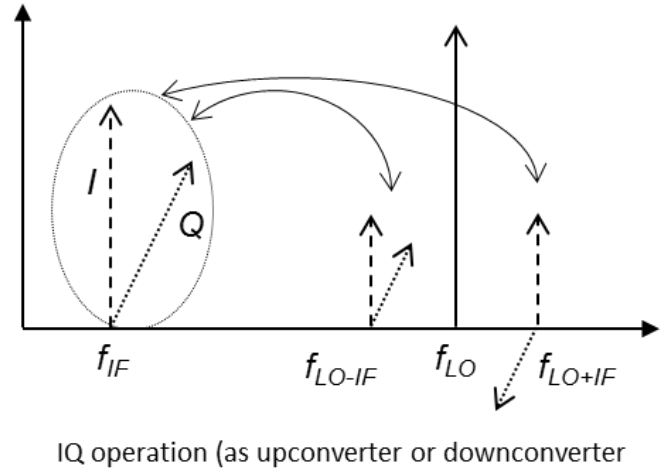
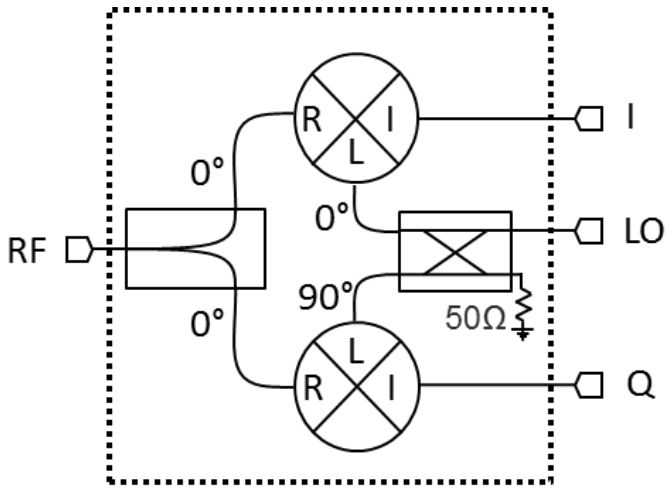

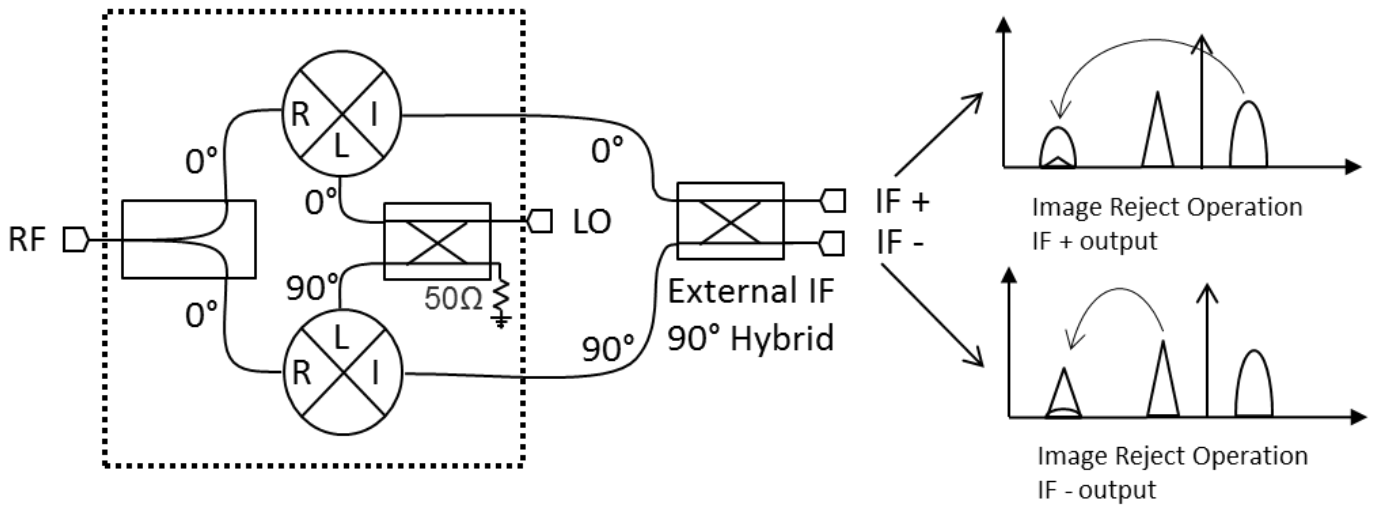

MMIQ-0205HXA

MMIC Double-Balanced I/Q Mixer

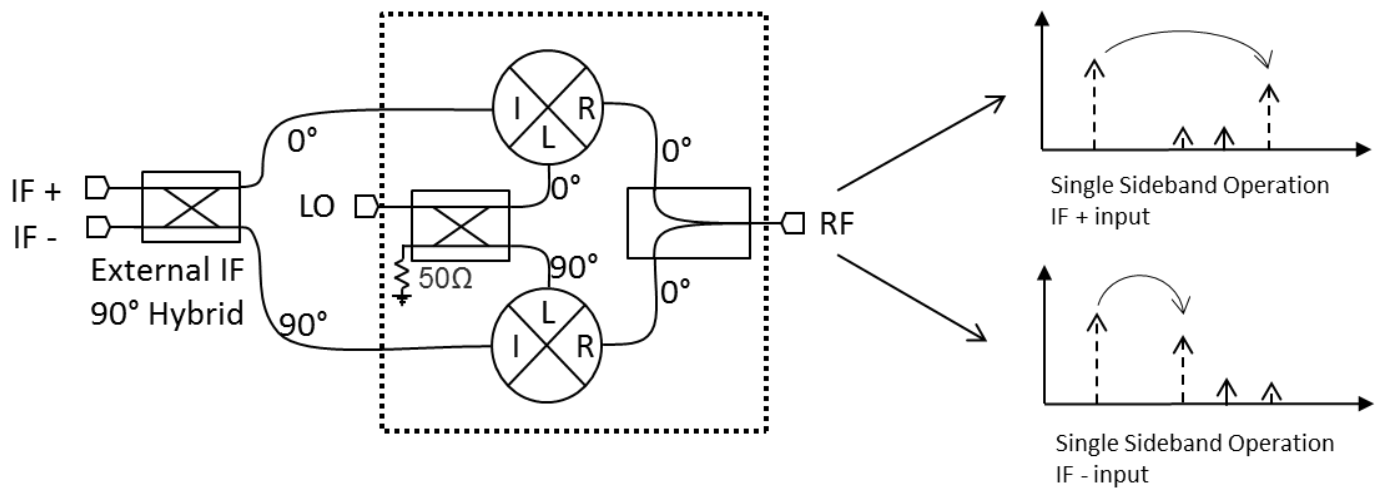

Mechanical Data

Outline Drawing

Download : [Outline 2D Drawing](#)

Port	Connector Type
LO	SMA Female
RF	SMA Female
I/Q	SMA Female

Note: Connectors are not removable.

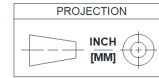

All dimension are typical

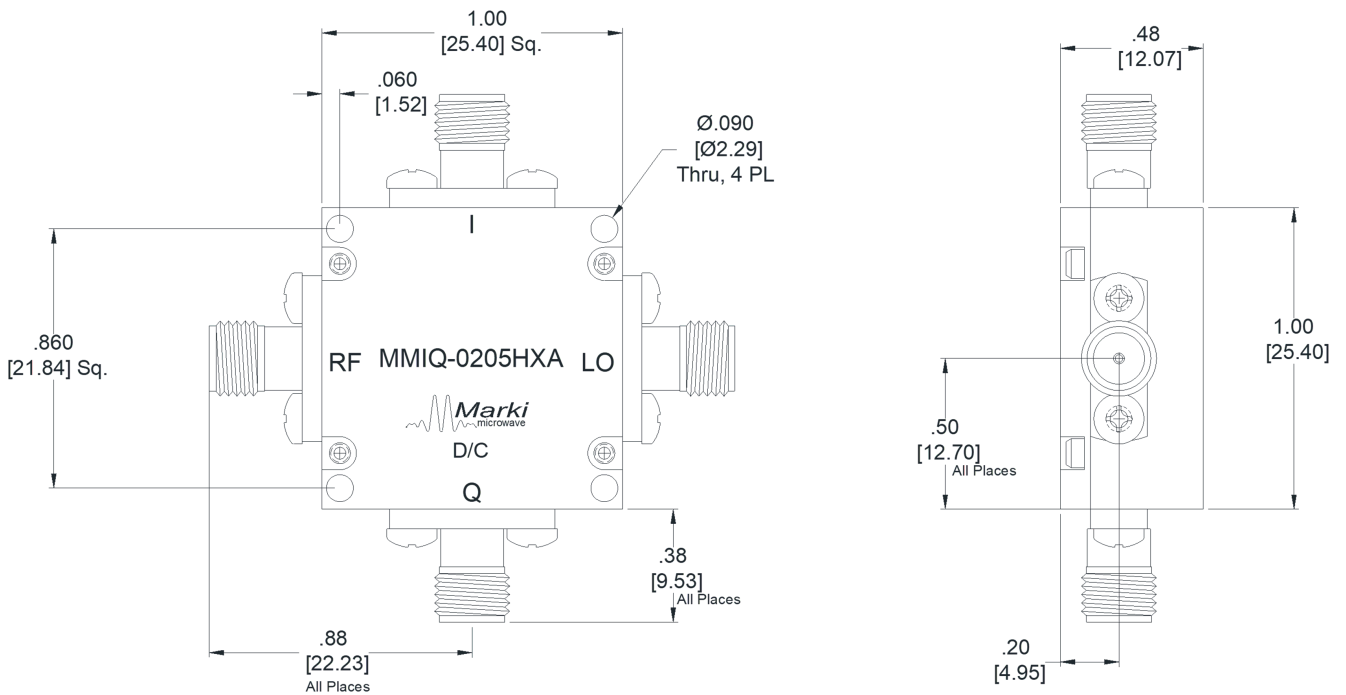

Evaluation Board - Performance Data

Parameter	Test Conditions	Frequency Range (GHz)	Min	Typ	Max	Unit
RF Frequency Range	-	-	1.75	-	5	GHz
Image Rejection	-	-	-	33	-	dBc
Isolation, LO to RF	-	-	-	60	-	dB
IF Frequency Range	-	-	0	-	2	GHz
LO Frequency Range	-	-	1.75	-	5	GHz

DISCLAIMER

MARKI MICROWAVE, LLC., ("MARKI") PROVIDES TECHNICAL SPECIFICATIONS AND DATA (INCLUDING DATASHEETS), APPLICATION OR OTHER DESIGN ADVICE, WEB TOOLS, AND OTHER INFORMATION AND RESOURCES "AS IS" AND WITH ALL FAULTS. MARKI DISCLAIMS ALL WARRANTIES, EXPRESS OR IMPLIED, INCLUDING, WITHOUT LIMITATION, ANY IMPLIED WARRANTIES OF MERCHANTABILITY, FITNESS FOR A PARTICULAR PURPOSE, OR NON-INFRINGEMENT.

These resources are intended for developers skilled in the art designing with Marki products. You are solely responsible for (1) selecting the appropriate products for your application, (2) designing, validating, and testing your application, and (3) ensuring your application meets applicable standards and other requirements. Marki makes no guarantee regarding the suitability of its products for any particular purpose, nor does Marki assume any liability whatsoever arising out of your use or application of any Marki product.

Marki grants you permission to use these resources only for development of an application that uses Marki products. Other reproduction or use of these resources is strictly prohibited. No license is granted to any other Marki intellectual property or to any third-party intellectual property. Marki reserves the right to make changes to the product(s) or information contained herein without notice.

MARKI MICROWAVE and T3 MIXER are trademarks or registered trademarks of Marki Microwave, LLC. All other trademarks used are the property of their respective owners.

© 2022 - 2026, Marki Microwave, LLC