

# NLTL-6273SM

## GaAs MMIC Non-Linear Transmission Line

### DEVICE OVERVIEW

#### General Description

NLTL-6273SM is a MMIC non-linear transmission line (NLTL) based comb generator. This NLTL offers excellent phase noise performance over a low 0.7 to 5 GHz input frequency range with output tones to 24 GHz. NLTL-6273SM is fabricated with GaAs Schottky diode based varactors and packaged into a surface mount 5x5 mm<sup>2</sup> QFN.

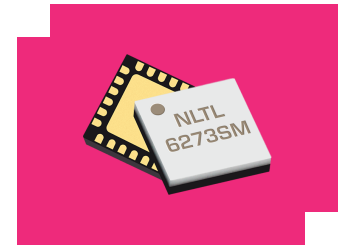

#### Features

- Low Phase Noise
- Broadband Input Frequencies
- No External DC Bias Required

#### Applications

- Comb Line Generation
- High Efficiency Multiplication
- Samplers
- Phase Locked Loops

#### Functional Block Diagram

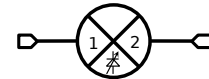

#### Part Ordering Options

Part Number	Description	Package	Packing Size	Green Status	Product Lifecycle	Export Classification
NLTL-6273SM	GaAs MMIC Non-Linear Transmission Line	QFN	-	RoHS REACH	Released	EAR99
EVAL-NLTL-6273	Evaluation Board, GaAs MMIC 0.7-5 GHz Non-Linear Transmission Line	EVAL	-	RoHS REACH	Released	EAR99
NLTL-6273-TR	Tape and Reel, GaAs MMIC Non-Linear Transmission Line	QFN	13"	RoHS REACH	Released	EAR99

## Table Of Contents

- **Device Overview**
  - General Description
  - Features
  - Applications
  - Functional Block Diagram
- **Port Configuration and Functions**
  - Port Diagram
  - Port Functions
- **Revision History**
- **Specifications**
  - Absolute Maximum Ratings
  - Package Information
  - Recommended Operating Conditions
  - Sequencing Requirements
  - Electrical Specifications
  - Typical Performance Plots
  - Typical Performance Plots: Residual Phase Noise
- **Operation**
  - Application Information
  - Application Circuit
  - Application Circuit Description
- **Mechanical Data**
  - Outline Drawing
- **Footprint Image**
- **Evaluation Board**
  - Evaluation Board Outline Drawing

## Revision History

Revision Code	Revision Date	Comment
-	2017-10-01	Datasheet Initial Release
A	2017-10-01	Corrected typos
B	2019-08-01	Added DC Current Plot

## Port Configuration and Functions

### Port Diagram

A bottom-up view of the NLTL-6273's SM package outline drawing is shown below. The NLTL should only be used in the forward direction, with the input and output ports given in Port Functions.

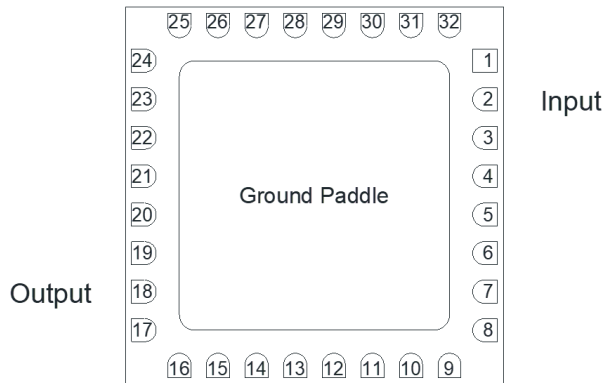

### Port Functions

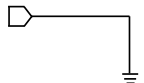
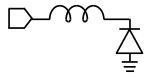
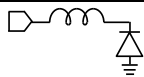
Port	Function	Description	DC Equivalent Circuit
GND	Ground	SM package ground path is provided through the ground paddle.	
Pin 18	Output	Pin 18 is diode connected for the SM package.	
Pin 2	Input	Pin 2 is diode connected for the SM package.	

## Specifications

### Absolute Maximum Ratings

The Absolute Maximum Ratings indicate limits beyond which damage may occur to the device. If these limits are exceeded, the device may be inoperable or have a reduced lifetime.

Parameter	Maximum Rating	Unit
Maximum Operating Temperature	100	°C
Maximum Storage Temperature	125	°C
Minimum Operating Temperature	-55	°C
Minimum Storage Temperature	-65	°C

### Package Information

Parameter	Details	Rating
Dimensions	-	5 x 5 mm
Moisture Sensitivity Level	-	MSL 1

### Recommended Operating Conditions

The Recommended Operating Conditions indicate the limits, inside which the device should be operated, to guarantee the performance given in Electrical Specifications. Operating outside these limits may not necessarily cause damage to the device, but the performance may degrade outside the limits of the electrical specifications. For limits, above which damage may occur, see Absolute Maximum Ratings.

Parameter	Min	Nominal	Max	Unit
Ambient Temperature	-55	25	100	°C
Input Power	16	-	26	dBm

## Sequencing Requirements

This is a passive NLTL that requires no external DC bias. Self-bias of the diodes is sufficient for operation. It is not required, but is recommended to provide a 50Ω termination to each port before applying RF power.

**Electrical Specifications**

The electrical specifications apply at TA=+25°C in a 50Ω system. Typical data shown is for the NLTL used in the forward direction with a +20 dBm sine wave input. Min and Max limits apply only to our connectorized units and are guaranteed at TA=+25°C. All bare die are 100% DC tested and visually inspected.

Parameter	Test Conditions	Minimum Frequency (GHz)	Maximum Frequency (GHz)	Min	Typ	Max	Unit
Input Frequency Range	-	-	-	0.7	-	5	GHz
Input Power	-	-	-	16	-	26	dBm
Maximum Output Harmonic for given Input	2 GHz Input	-	-	-	-	12	
Maximum Output Harmonic for given Input	4 GHz Input	-	-	-	-	8	
Maximum Output Harmonic for given Input	5 GHz Input	-	-	-	-	6	
Maximum Output Harmonic for given Input	700 MHz Input	-	-	-	-	8	
Output Frequency Range	-	-	-	0.7	-	24	GHz
Maximum Output Harmonic for given Input	1 GHz Input	-	-	-	-	24	

Typical Performance Plots

### Typical Performance Plots

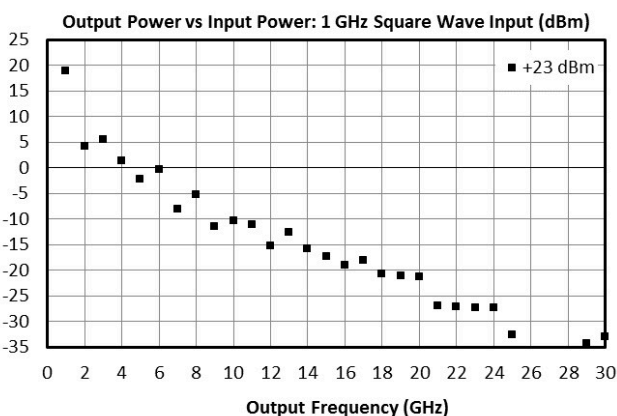
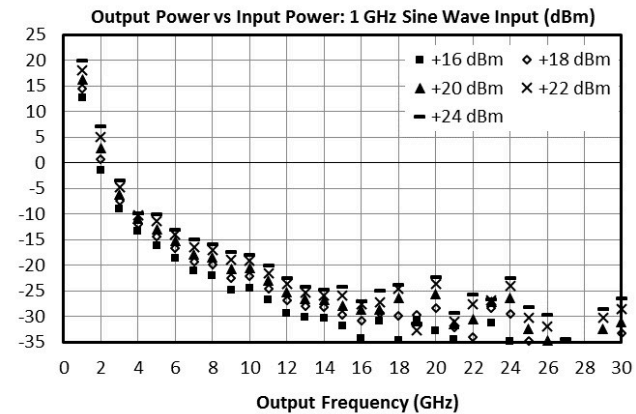
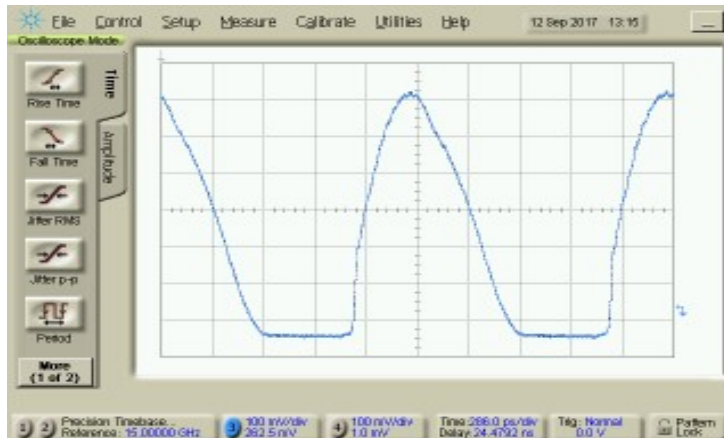
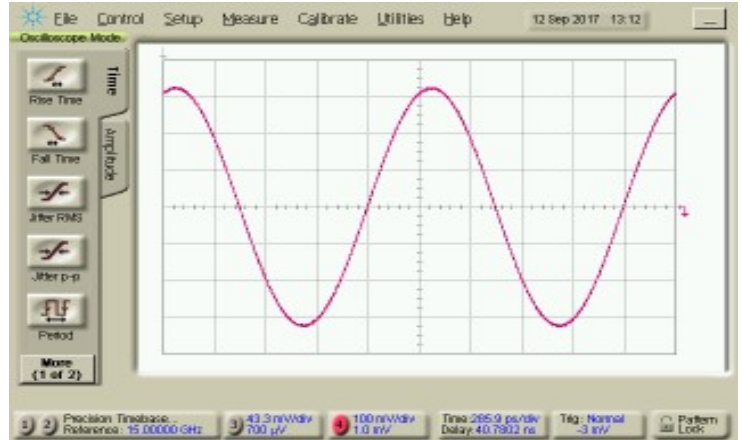
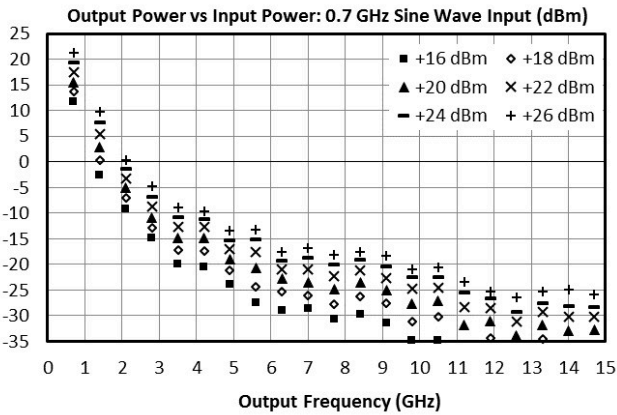

## NLTL-6273SM

### GaAs MMIC Non-Linear Transmission Line

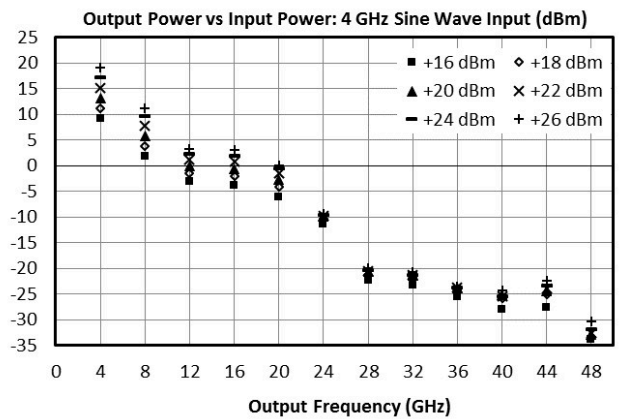
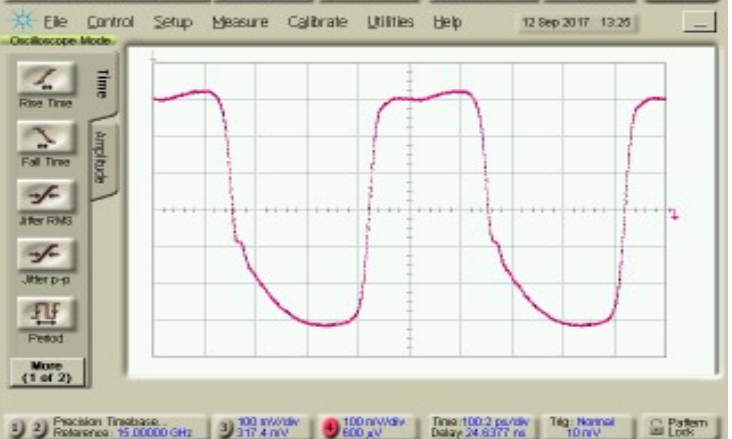
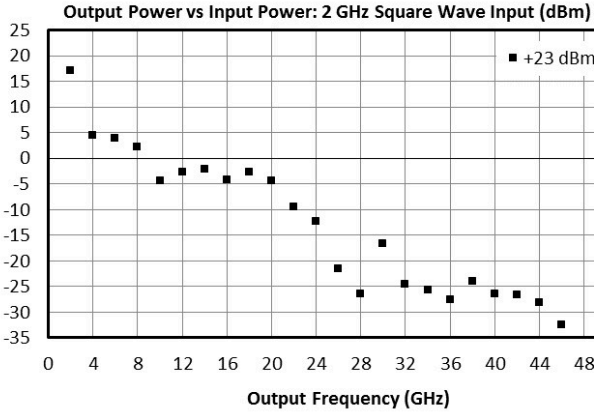
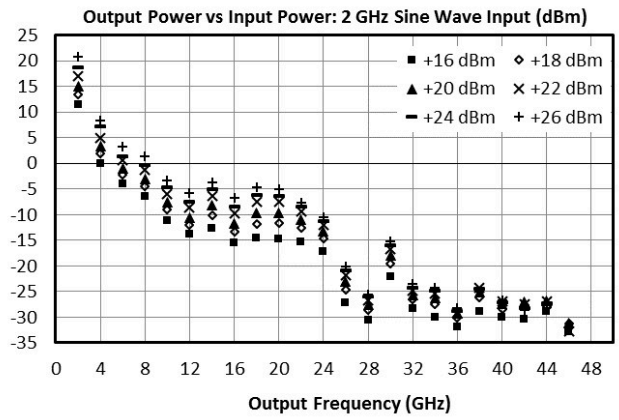
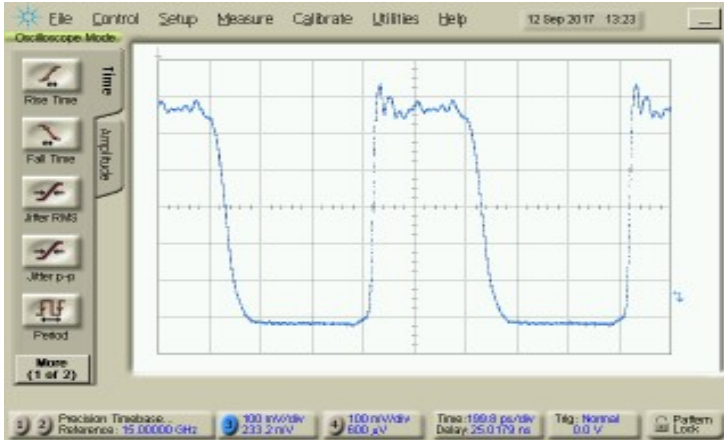

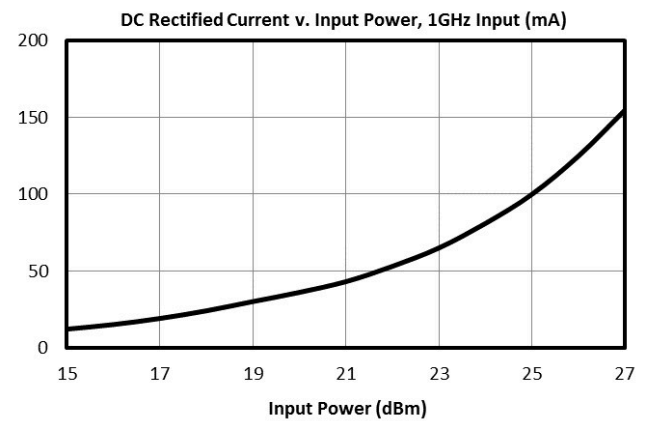
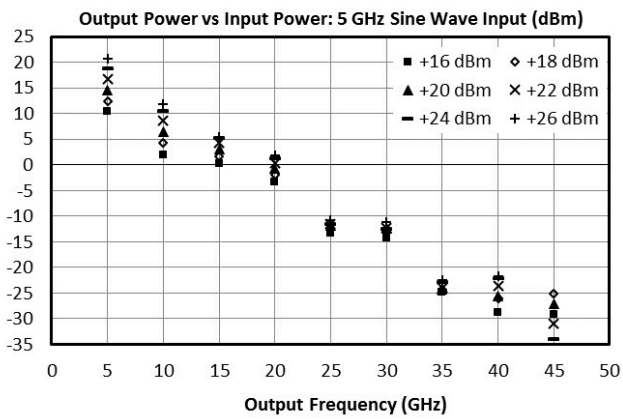

**Typical Performance Plots: Residual Phase Noise**

1 GHz, +23 dBm Sine Wave Input	Parameter	Min	Typical	Max	Units
5 <sup>th</sup> Output Harmonic	1 Hz Offset		-120		dBc/Hz
	10 Hz Offset		-130		
	100 Hz Offset		-140		
	1 KHz Offset		-150		
	10 KHz Offset		-160		
	100 KHz Offset		-170		
	1 MHz Offset		Thermal Floor		

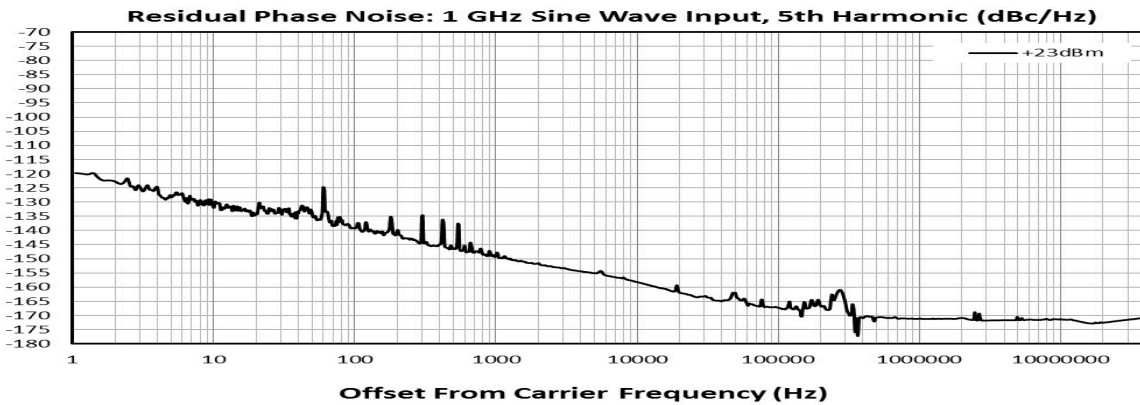

**Application Information**

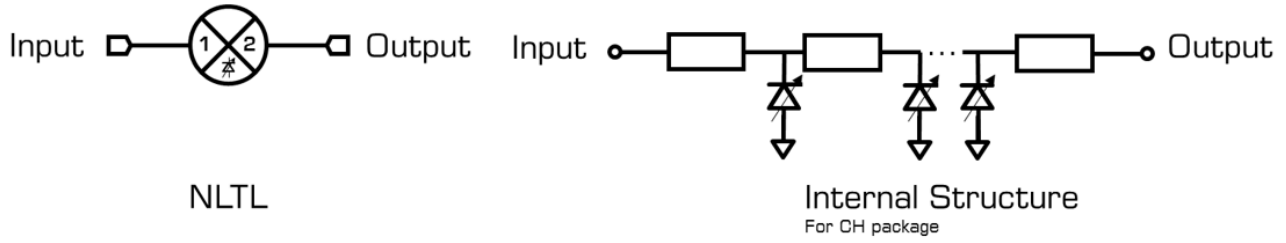

#### Detailed Description

NLTL-6273SM belongs to Marki Microwave's NLTL family of multipliers and non-linear transmission lines. The NLTL product line consists of passive GaAs MMIC non-linear transmission lines designed and fabricated with GaAs Schottky diode based varactors. NLTLs take an input signal and create an impulse train of harmonics. Harmonic outputs up to and beyond 24 GHz are generated by the NLTL. The NLTL-6273SM is the packaged 5 mm QFN version of the NLTL-6273CH.

Port 1 supports L and S band input signals. Port 2 will output integer multiples of the input signal (i.e., x2, x3, x4, ..., x24) up to the 24<sup>th</sup> output harmonic or a maximum of 24 GHz. Higher harmonics can be generated but will be at a lower efficiency.

The operating conditions of the NLTL are extremely important to optimize performance. High power inputs will increase the output power observed; however, the conversion efficiency will decrease. This is increasingly true for higher input frequencies and at input powers above the recommended limit. Optimal conversion efficiency of the NLTL is achieved using a square wave input with a fast rise time. Doing so causes a degradation in the 2<sup>nd</sup> output harmonic but otherwise improves the conversion efficiency at all other harmonics.

NLTL-6273SM requires no external DC bias. The self-bias of the diodes caused by the rectified RF input signal is sufficient for operation. For the best performance, optimization of the DC return path is recommended for each specific application to optimize the harmonic output power distribution.

The phase noise of a non-linear transmission line is outstanding. If verification of performance is necessary, the application circuit used and input conditions are extremely important. NLTLs are AM sensitive. If there is excessive AM noise on the input of the NLTL, observing the output of the NLTL will show excessive PM/phase noise because of the high AM to PM conversion property of NLTLs.

**Application Circuit**

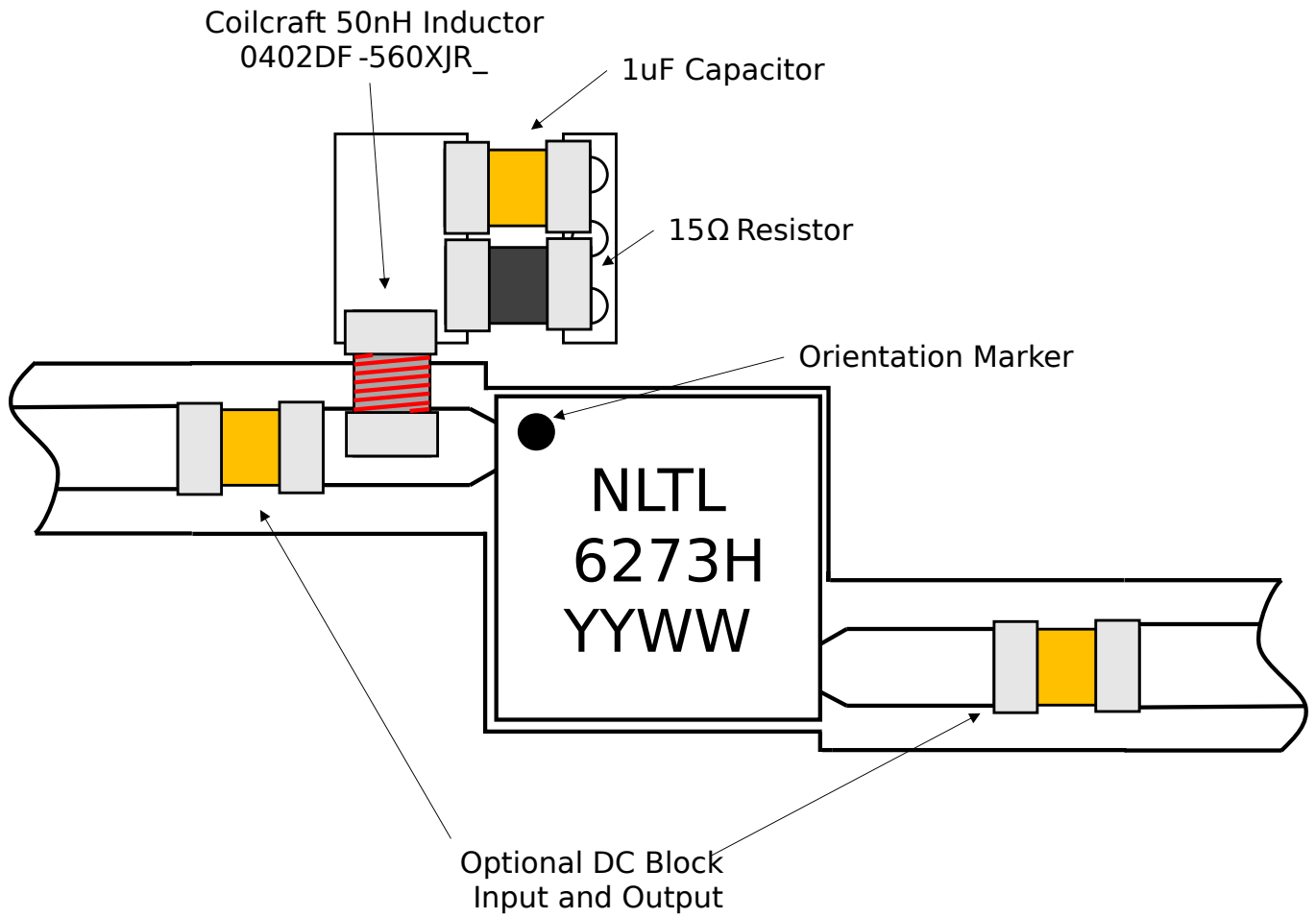

### Application Circuit Description

**DC Path to Ground** – An RF choke followed by a  $15\ \Omega$  resistor should be used to provide a DC path to ground on the input port of the NLTL. A shunt  $1\ \mu\text{F}$  capacitor is used to filter noise generated by the resistor. This forms the circuit which self-biases the NLTL. The DC return to ground removes DC rectified current created by high power RF signal injection. The DC path to ground is provided within the S package. A conical coil inductor is recommended to push the self-resonance frequency of the inductor past the operating bandwidth of the NLTL. The recommended inductance value of the conical coil inductor is 50nH or higher.

**Blocking Capacitor** – A DC blocking capacitor on the output of the NLTL-6273SM's integrated circuit is necessary to prevent unwanted DC current flow from or to the output. If there is a DC signal on the input, place a DC block on the input to avoid disrupting the self-biasing of the diodes.

### Mechanical Data

### Outline Drawing

Download : [Outline 2D Drawing](#) | [Outline 3D Drawing](#) | [Outline 3D STP](#)

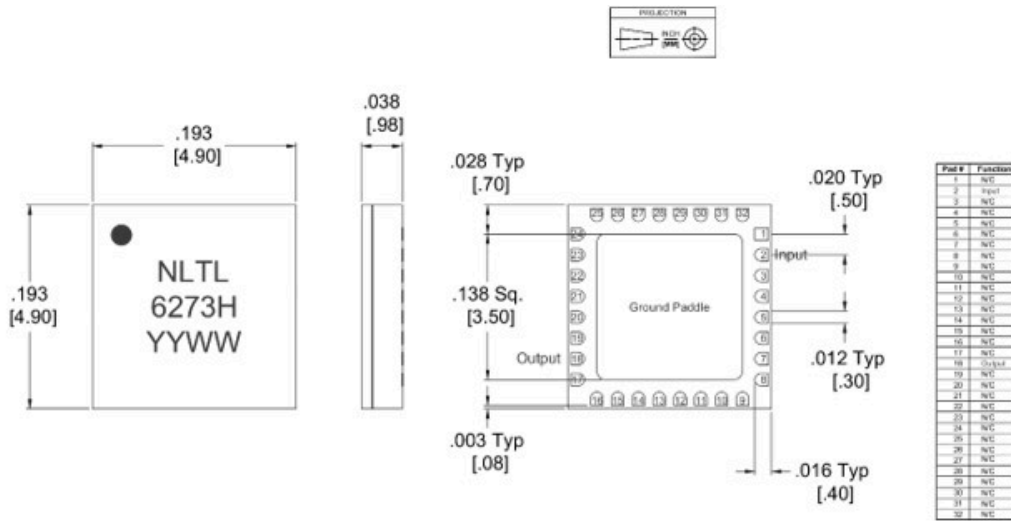

- Substrate material is ceramic.
- I/O Leads and Ground Paddle plating is (from base to finish):
 

Ni:	8.89um MAX	1.27um MIN
Pd:	0.17um MAX	0.07um MIN
Au:	0.254um MAX	0.03um MIN
- All unconnected pads should be connected to PCB RF ground.

**Footprint Image**

Download : [Footprint Drawing](#)

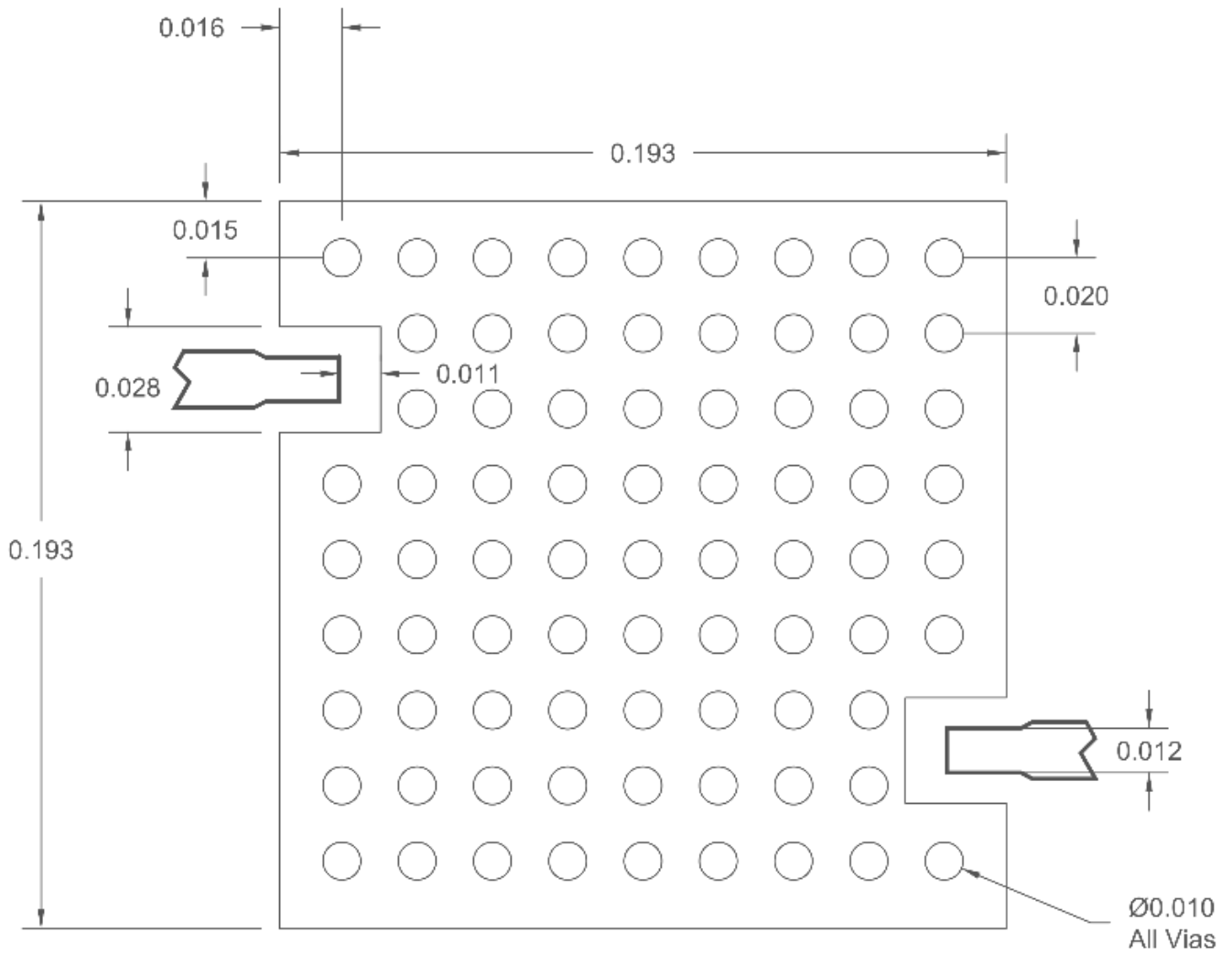

**Evaluation Board - Outline Drawing**

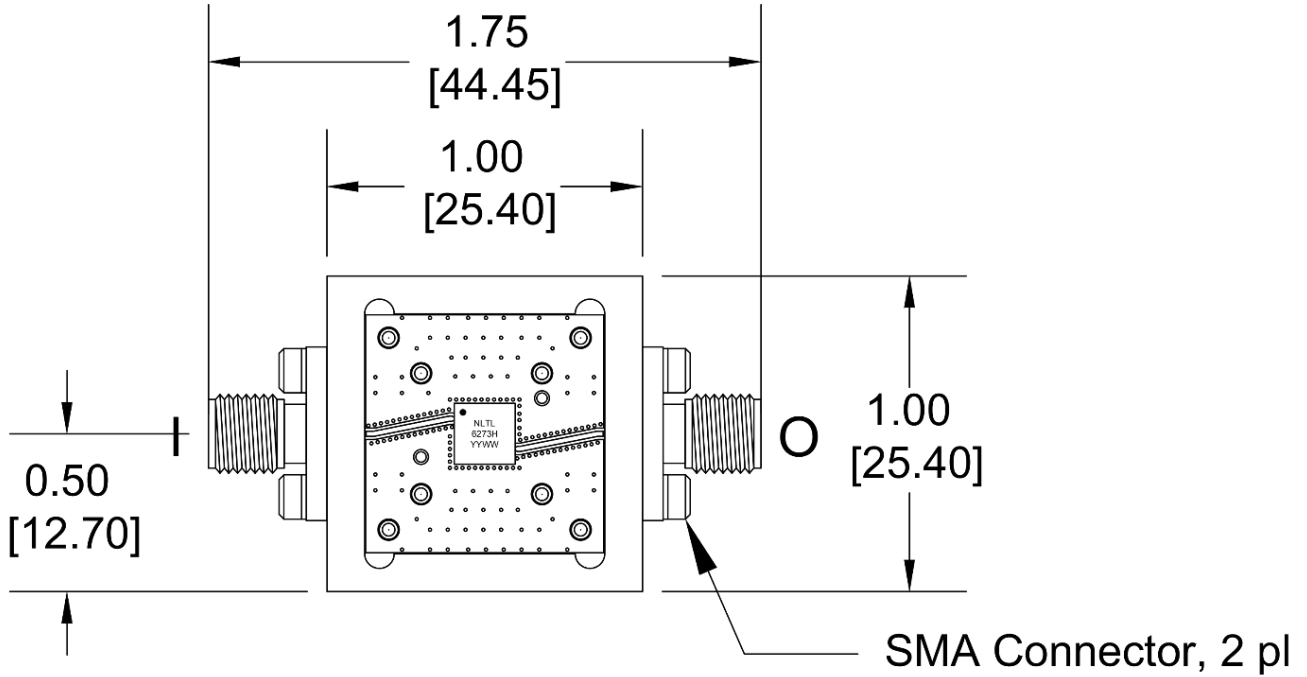

**DISCLAIMER**

MARKI MICROWAVE, LLC., ("MARKI") PROVIDES TECHNICAL SPECIFICATIONS AND DATA (INCLUDING DATASHEETS), APPLICATION OR OTHER DESIGN ADVICE, WEB TOOLS, AND OTHER INFORMATION AND RESOURCES "AS IS" AND WITH ALL FAULTS. MARKI DISCLAIMS ALL WARRANTIES, EXPRESS OR IMPLIED, INCLUDING, WITHOUT LIMITATION, ANY IMPLIED WARRANTIES OF MERCHANTABILITY, FITNESS FOR A PARTICULAR PURPOSE, OR NON-INFRINGEMENT.

These resources are intended for developers skilled in the art designing with Marki products. You are solely responsible for (1) selecting the appropriate products for your application, (2) designing, validating, and testing your application, and (3) ensuring your application meets applicable standards and other requirements. Marki makes no guarantee regarding the suitability of its products for any particular purpose, nor does Marki assume any liability whatsoever arising out of your use or application of any Marki product.

Marki grants you permission to use these resources only for development of an application that uses Marki products. Other reproduction or use of these resources is strictly prohibited. No license is granted to any other Marki intellectual property or to any third-party intellectual property. Marki reserves the right to make changes to the product(s) or information contained herein without notice.

MARKI MICROWAVE and T3 MIXER are trademarks or registered trademarks of Marki Microwave, LLC. All other trademarks used are the property of their respective owners.

© 2017, 2019, Marki Microwave, LLC