

# MM1-0626SCSP2

## GaAs MMIC Chip Scale Package Double Balanced Mixer

### DEVICE OVERVIEW

#### General Description

The MM1-0626SCSP2 is a highly linear passive GaAs double balanced MMIC mixer suitable for both up and down-conversion applications. As with all Marki Microwave mixers, it features excellent conversion loss, isolation and spurious performance across a broad bandwidth and in a small form factor. The MM1-0626SCSP2 is available in a lead-free, RoHS compliant 2.5x2.5 mm chip scale surface mount package (CSP2) and is compatible with standard leaded and lead-free PCB reflow soldering processes. The MM1-0626SCSP2 is a smaller alternative to the standard MM1-0626SSM.

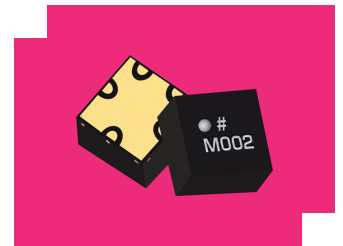

#### Features

- Compact 2.5x2.5 mm Chip Scale Package
- Broadband Performance
- Excellent Unit-to-Unit Repeatability
- RoHS Compliant

#### Applications

- Test and Measurement Equipment
- SATCOM
- 5G
- Electronic Warfare

#### Functional Block Diagram

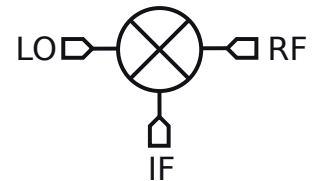

#### Part Ordering Options

Part Number	Description	Package	Green Status	Product Lifecycle	Export Classification
MM1-0626SCSP2	GaAs MMIC Chip Scale Package Double Balanced Mixer	CSP2	REACH RoHS	Released	EAR99
EVB-MM1-0626S	CSP Double Balanced Mixer Evaluation Board	EVB		Released	EAR99

## MM1-0626SCSP2

### GaAs MMIC Chip Scale Package Double Balanced Mixer

#### Table Of Contents

##### ■ Device Overview

- General Description
- Features
- Applications
- Functional Block Diagram

##### ■ Port Configuration and Functions

- Port Diagram
- Port Functions

##### ■ Revision History

##### ■ Specifications

- Absolute Maximum Ratings
- Package Information
- Recommended Operating Conditions
- Sequencing Requirements
- Electrical Specifications
- Typical Performance
- Spur Tables

##### ■ Operation

- Application Circuit
- Application Circuit Description

##### ■ Mechanical Data

- Outline Drawing

##### ■ Footprint Image

##### ■ Evaluation Board

#### Revision History

Revision Code	Revision Date	Comment
-	2024-07-30	Initial Release
A	2025-04-28	Updated Moisture Sensitivity from MSL3 to MSL1

## MM1-0626SCSP2

### GaAs MMIC Chip Scale Package Double Balanced Mixer

## Port Configuration and Functions

### Port Diagram

A bottom-up view of the MM1-0626SCSP2's CSP2 package outline drawing is shown below. The MM1-0626SCSP2 has the input and output ports given in Port Functions. The MM1-0626SCSP2 can be used in either an up or down conversion application. For configuration A, input the LO into pin 1, use pin 3 for the RF, and pin 2 for the IF. For configuration B, input the LO into pin 3, use pin 1 for the RF, and pin 2 for the IF.

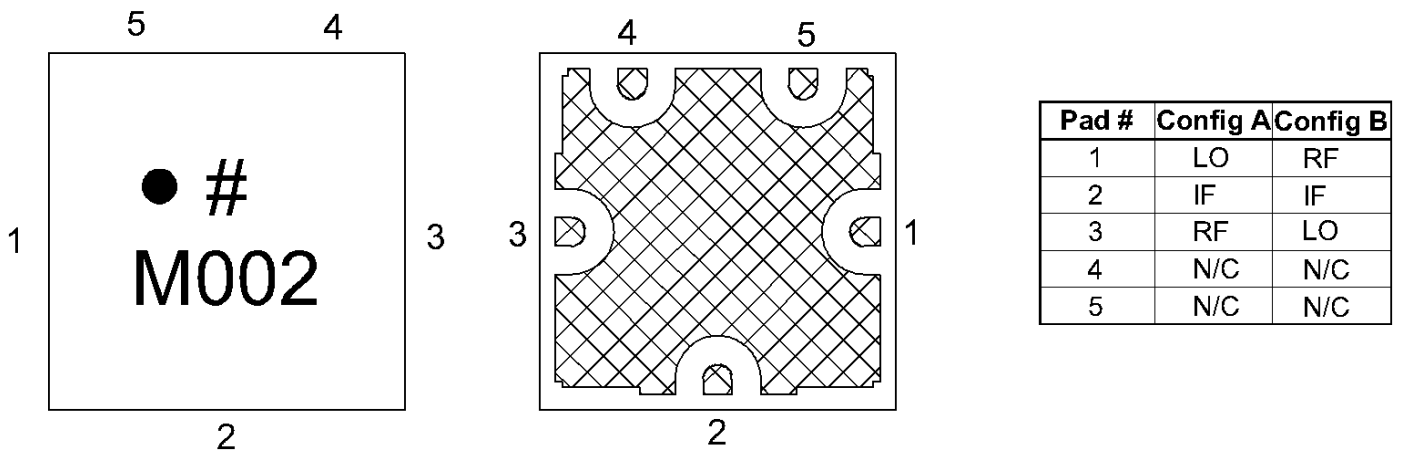

## Port Functions

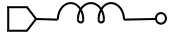
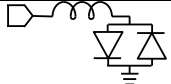
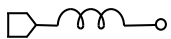

### Configuration A

Port	Function	Description	DC Equivalent Circuit
Pin 1	LO	Pin 1 is DC open and AC matched to 50 Ohms from 6 to 26.5 GHz. Blocking capacitor is optional.	
Pin 2	IF	Pin 2 is DC coupled to the diodes. Blocking capacitor is optional.	
Pin 3	RF	Pin 3 is DC open and AC matched to 50 Ohms from 6 to 26.5 GHz. Blocking capacitor is optional.	
Pin 4,5	N/C	Pins 4 and 5 are not internally connected to the circuit and should be connected to GND.	-

## MM1-0626SCSP2

### GaAs MMIC Chip Scale Package Double Balanced Mixer

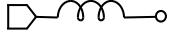
#### Configuration B

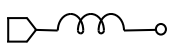
Port	Function	Description	DC Equivalent Circuit
Pin 1	RF	Pin 1 is DC open and AC matched to 50 Ohms from 6 to 26.5 GHz. Blocking capacitor is optional.	
Pin 2	IF	Pin 2 is DC coupled to the diodes. Blocking capacitor is optional.	
Pin 3	LO	Pin 3 is DC open and AC matched to 50 Ohms from 6 to 26.5 GHz. Blocking capacitor is optional.	
Pin 4,5	N/C	Pins 4 and 5 are not internally connected to the circuit and should be connected to GND.	-

## Specifications

### Absolute Maximum Ratings

The Absolute Maximum Ratings indicate limits beyond which damage may occur to the device. If these limits are exceeded, the device may be inoperable or have a reduced lifetime.

Parameter	Maximum Rating	Unit
Maximum Operating Temperature	100	°C
Maximum Storage Temperature	125	°C
Minimum Operating Temperature	-55	°C
Minimum Storage Temperature	-65	°C
Pin 2 DC Current	15	mA
RF Power Handling (RF+LO), 100°C	21	dBm
RF Power Handling (RF+LO), 25°C	28	dBm

### Package Information

Parameter	Details	Rating
ESD	250 to < 500 Volts	HBM Class 1A
Dimensions	-	2.50 x 2.50 mm
Moisture Sensitivity Level	-	MSL 1

### Recommended Operating Conditions

The Recommended Operating Conditions indicate the limits, inside which the device should be operated, to guarantee the performance given in Electrical Specifications. Operating outside these limits may not necessarily cause damage to the device, but the performance may degrade outside the limits of the electrical specifications. For limits, above which damage may occur, see Absolute Maximum Ratings.

Parameter	Min	Nominal	Max	Unit
LO Input Power	13	20	24	-

### Sequencing Requirements

There is no requirement to apply power to the ports in a specific order. However, it is recommended to provide a 50Ω termination to each port before applying power. This is a passive diode mixer that requires no DC bias.

#### Electrical Specifications

The electrical specifications apply at TA=+25°C in a 50Ω system. Typical data shown is for a down conversion application with a +20 dBm sine wave LO input.

Parameter	Port Configuration	Test Conditions	Min	Typ	Max	Unit
Conversion Loss <sup>1</sup>	A	LO=6-26GHz RF=6-26.5GHz IF=DC-9GHz LO drive level=20dBm	-	7.5	-	dB
Input IP3	A	LO=6-26GHz RF=6-26.5GHz IF=DC-9GHz LO drive level=18-23dBm	-	25	-	dBm
Input P1dB	A	LO=6-26GHz RF=6-26.5GHz IF=DC-9GHz LO drive level=20dBm	-	14	-	dBm
LO-IF Isolation <sup>2</sup>	A	LO=6-26GHz RF=6-26.5GHz IF=DC-9GHz LO drive level=18-23dBm	-	35	-	dB
LO-RF Isolation <sup>3</sup>	A	LO=6-26GHz RF=6-26.5GHz IF=DC-9GHz LO drive level=18-23dBm	-	45	-	dB
Noise Figure <sup>4</sup>	A	LO=6-26GHz RF=6-26.5GHz IF=DC-9GHz LO drive level=20dBm	-	7.5	-	dB
RF-IF Isolation <sup>5</sup>	A	LO=6-26GHz RF=6-26.5GHz IF=DC-9GHz LO drive level=18-23dBm	-	40	-	dB
Conversion Loss <sup>6</sup>	B	LO=6-26GHz RF=6-26.5GHz IF=DC-9GHz LO drive level=20dBm	-	8.5	-	dB
Input IP3	B	LO=6-26GHz RF=6-26.5GHz IF=DC-9GHz LO drive level=20dBm	-	27	-	dBm
Input P1dB	B	LO=6-26GHz RF=6-26.5GHz IF=DC-9GHz LO drive level=20dBm	-	14	-	dBm
LO-IF Isolation <sup>7</sup>	B	LO=6-26GHz RF=6-26.5GHz IF=DC-9GHz LO drive level=20dBm	-	40	-	dB
LO-RF Isolation <sup>8</sup>	B	LO=6-26GHz RF=6-26.5GHz IF=DC-9GHz LO drive level=20dBm	-	45	-	dB
Noise Figure <sup>9</sup>	B	LO=6-26GHz RF=6-26.5GHz IF=DC-9GHz LO drive level=20dBm	-	8.5	-	dB

# MM1-0626SCSP2

## GaAs MMIC Chip Scale Package Double Balanced Mixer

### Typical Performance

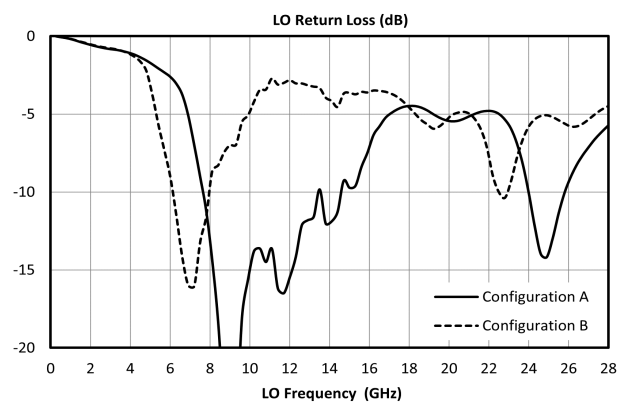
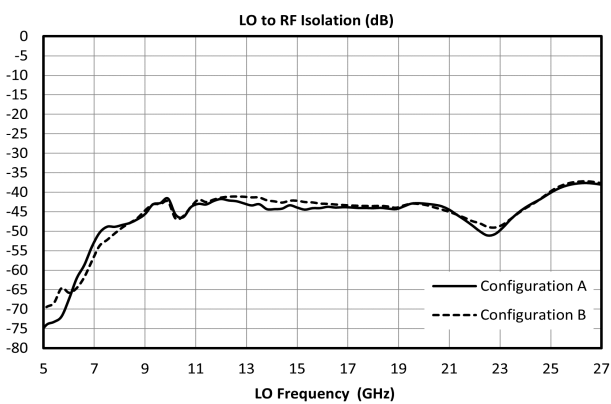
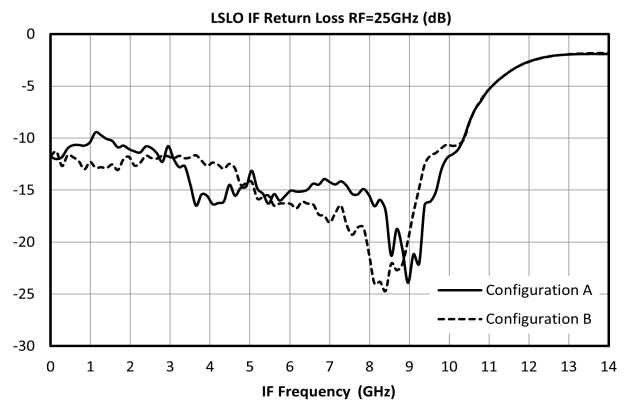
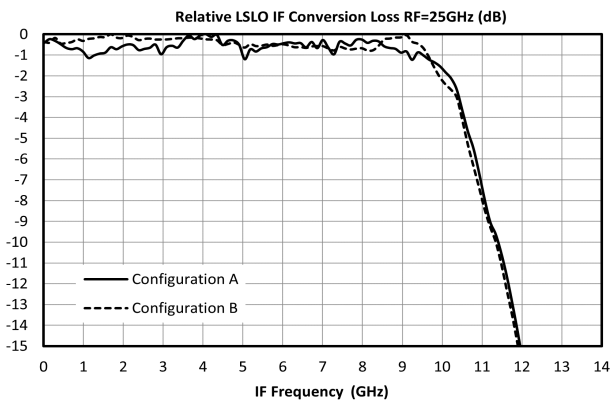
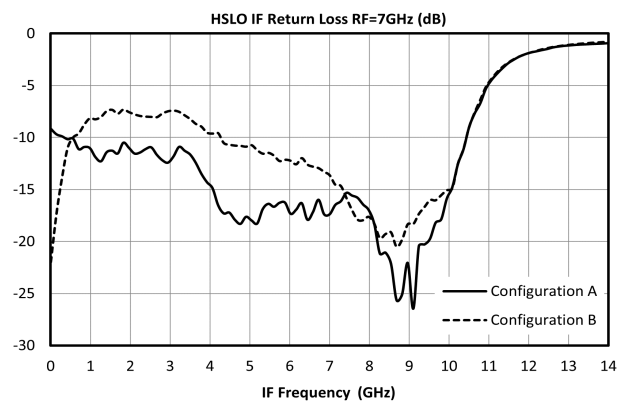
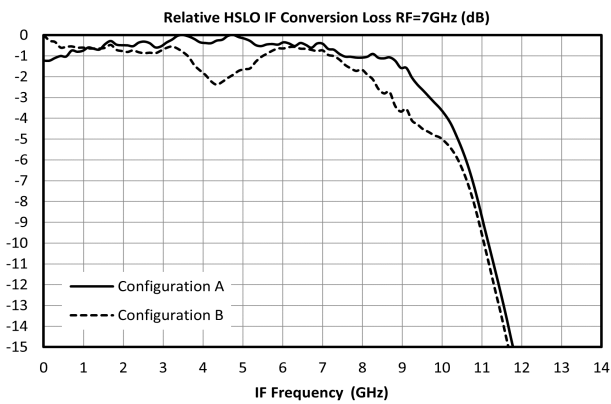
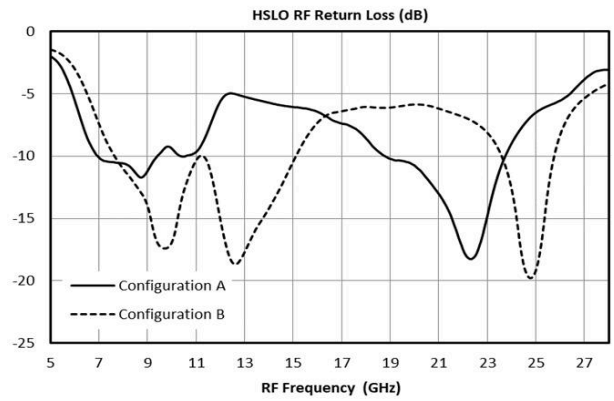
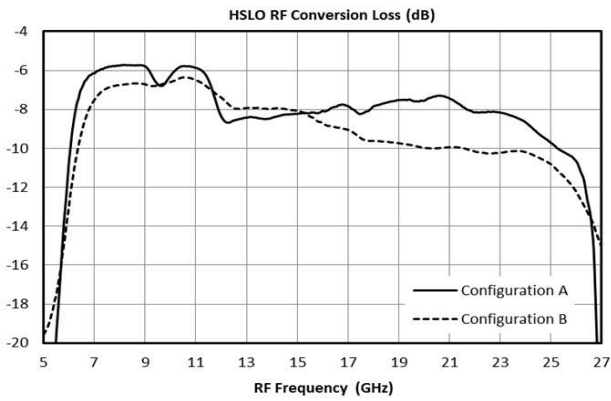

# MM1-0626SCSP2

## GaAs MMIC Chip Scale Package Double Balanced Mixer

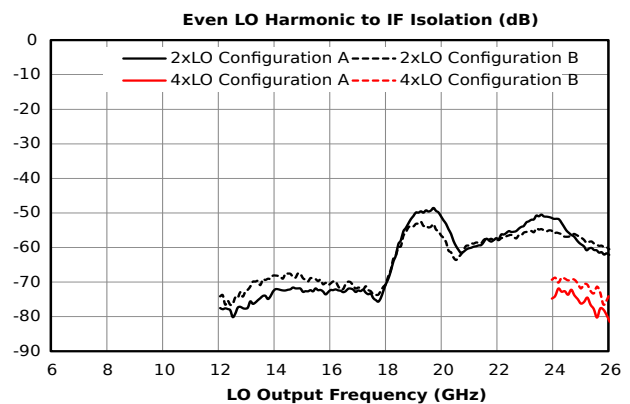
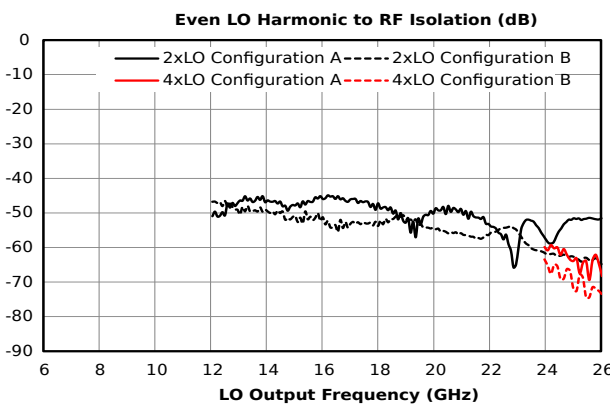
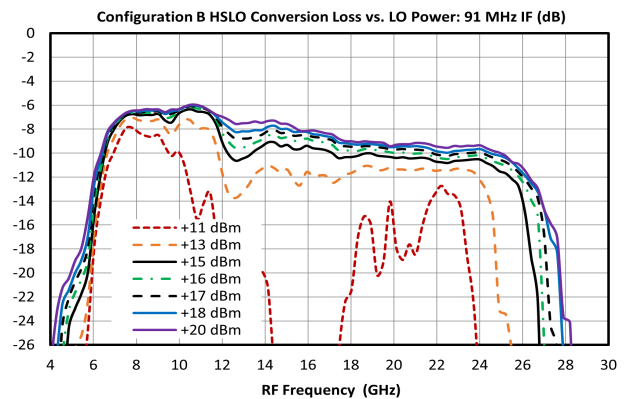
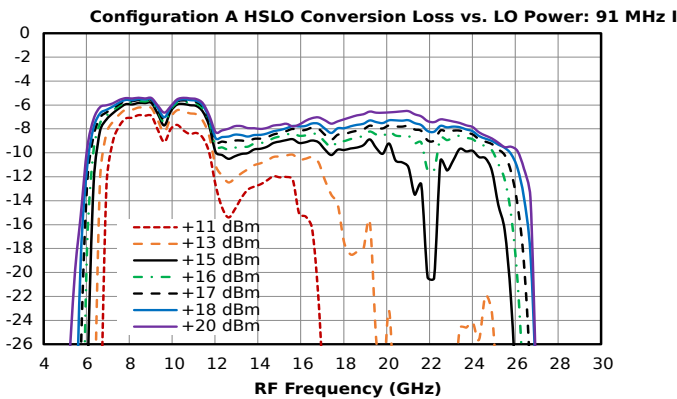
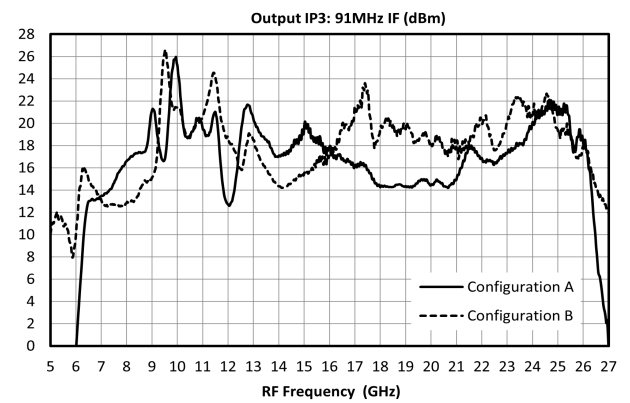
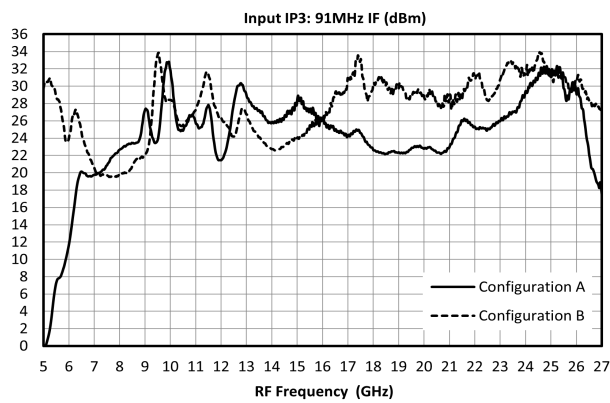
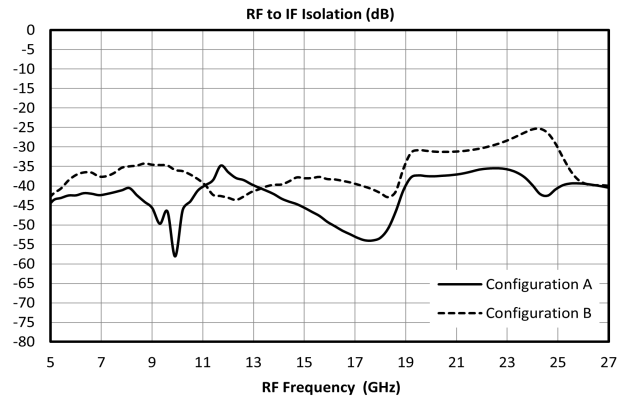
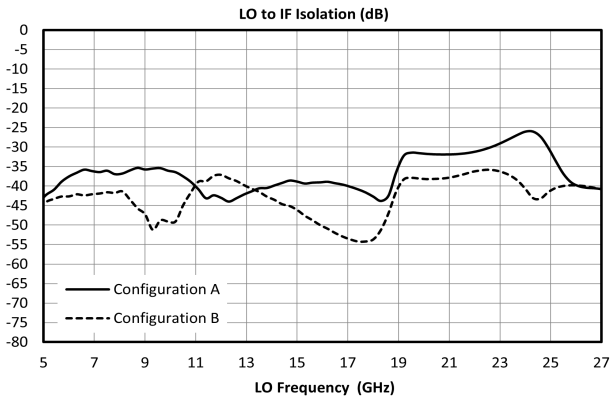

## MM1-0626SCSP2

### GaAs MMIC Chip Scale Package Double Balanced Mixer

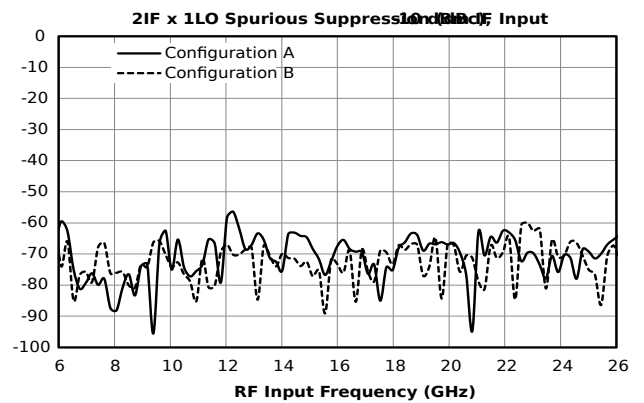
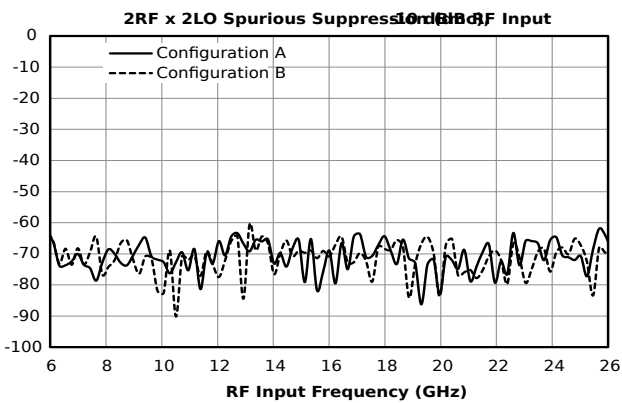
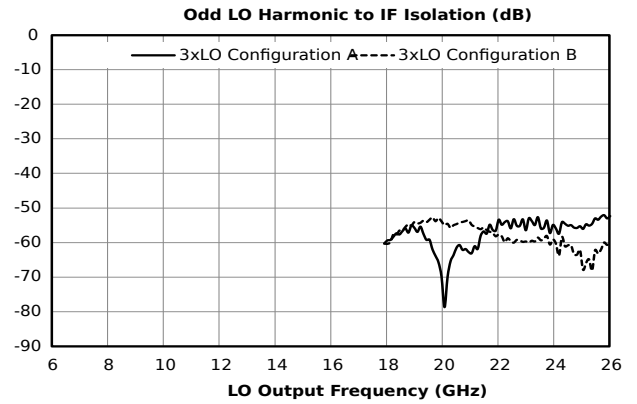
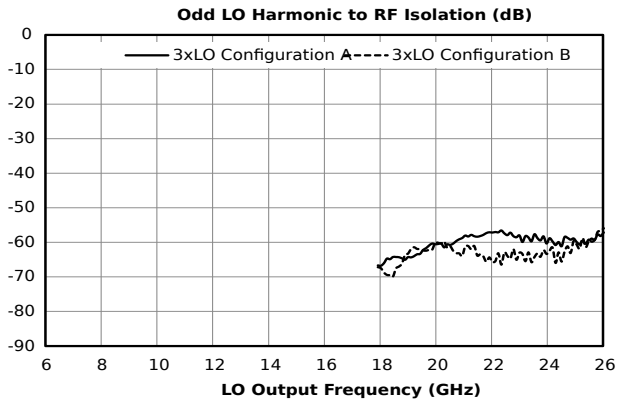

## Spur Table

### Downconversion Spurious Suppression

Spurious data is taken by selecting RF and LO frequencies (+mLO+nRF) within the 6 to 26 GHz RF/LO bands, which create a 91 MHz IF spurious output. The mixer is swept across the full spurious band and the mean is calculated. The numbers shown in the table below are for a -10 dBm RF input. Spurious suppression is scaled for different RF power levels by (n-1), where “n” is the RF spur order. For example, the 2RFx2LO spur is 74 dBc for the A configuration for a -10 dBm input, so a -20 dBm RF input creates a spur that is (2-1) x (-10 dB) dB lower, or 84 dBc.

Typical Downconversion Spurious Suppression (dBc): A Configuration (B Configuration), Sine Wave LO						
-10 dBm RF Input	0xLO	1xLO	2xLO	3xLO	4xLO	5xLO
1×RF	29 (29)	Reference	37 (39)	17 (15)	46 (34)	32 (17)
2xRF	78 (82)	64 (78)	74 (77)	72 (76)	76 (77)	71 (75)
3xRF	87 (90)	79 (84)	88 (86)	82 (88)	85 (88)	85 (88)
4xRF	97 (102)	96 (98)	95 (97)	94(97)	96 (97)	96 (99)
5xRF	108 (109)	108 (107)	107 (105)	106 (107)	105 (107)	106 (107)

Specifications are subject to change without notice. Contact Marki Microwave for the most recent specifications and data sheets.

#### Upconversion Spurious Suppression

Spurious data is taken by mixing a 91 MHz IF with LO frequencies(+mLO+nIF), which creates an RF within the 6 to 26 GHz RF band. The mixer is swept across the full spurious output band and the mean is calculated. The numbers shown in the table below are for a -10 dBm IF input. Spurious suppression is scaled for different IF input power levels by (n-1), where “n” is the IF spur order. For example, the 2IFx1LO spur is typically 80 dBc for the A configuration for a -10 dBm input, so a -20 dBm IF input creates a spur that is (2-1) x (-10 dB) dB lower, or 90 dBc.

Typical Upconversion Spurious Suppression (dBc): A Configuration (B Configuration), Sine Wave LO						
-10 dBm IF Input	0xLO	1xLO	2xLO	3xLO	4xLO	5xLO
1×RF	33 [28]	Reference	40 [41]	18(16)	50 (35)	45 (16)
2xRF	84 (83)	80 (81)	82 (79)	81(81)	79 (70)	79 (79)
3xRF	91 (89)	89 (89)	90 (89)	91(92)	88 (90)	87 (87)
4xRF	98 (101)	100 (101)	99 (99)	98 (99)	99(98)	100 (99)
5xRF	109 (110)	110 [111]	110 (109)	110 (110)	108 (111)	108 (111)

Specifications are subject to change without notice. Contact Marki Microwave for the most recent specifications and data sheets.

## MM1-0626SCSP2

### GaAs MMIC Chip Scale Package Double Balanced Mixer

#### Application Circuit

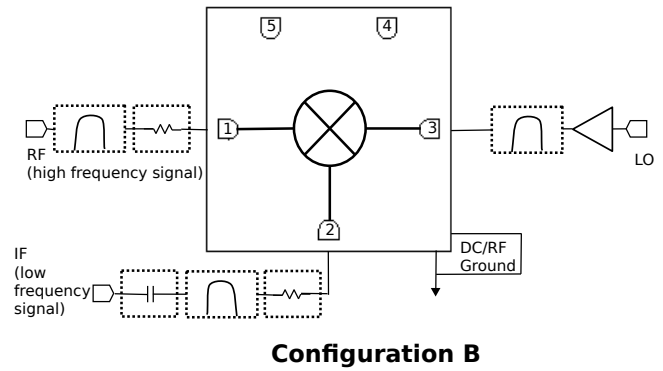
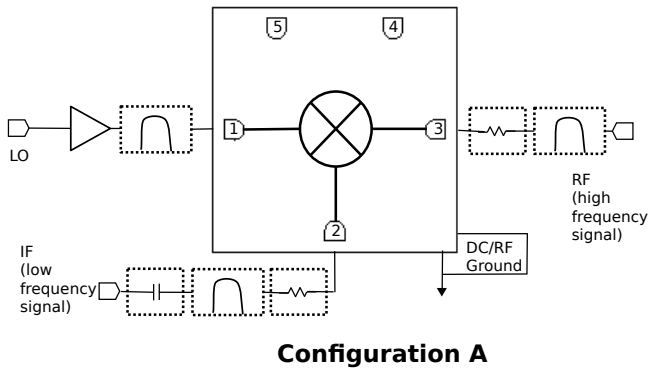

## Application Circuit Description

### Ports Operation

**IF Port** – Used as input on an upconversion, output on downconversion, or LO port in a band shifting application. Signals should be connected by 50 ohm microstrip or coplanar traces to well matched broadband 50 ohm sources and loads. Blocking capacitor is recommended if DC voltage is present on the line.

**RF Port** – Used as input on a downconversion, output on upconversion, or output in a band shifting application. Signals should be connected by 50 ohm microstrip or coplanar traces to well matched broadband 50 ohm sources and loads.

**Filtering and Matching**- Filtering is generally desired for spurious and image removal on the output port of the mixer. Reflective filters can cause out of band signals to reflect back into the mixer and cause conversion loss ripple, erroneous spurs, and other undesired behaviors. To eliminate these problems it is recommend that the filters be placed as close to the output port as possible. If undesired behavior is still observed, a diplexer with one port terminated or a 1-3 dB attenuator may reduce this problem.

**RF Ground** – The ground paddle of the QFN should be connected to a low noise RF ground with very low electrical resistance for high frequency operation.

**LO Port** – The noise floor of the LO input signal should be less than the value of the noise floor plus isolation of the mixer, or a filter is recommended to prevent reduction in dynamic range. An LO amplifier is required if the LO power is below the recommended drive level. It is important to use an amplifier with a broadband 50 ohm match such that it does not reflect spurious signals back into the mixer or other system circuitry.

# MM1-0626SCSP2

## GaAs MMIC Chip Scale Package Double Balanced Mixer

### Mechanical Data

### Outline Drawing

Download : [Outline 2D Drawing](#) | [Outline 3D Drawing](#) | [Outline 3D STP](#)

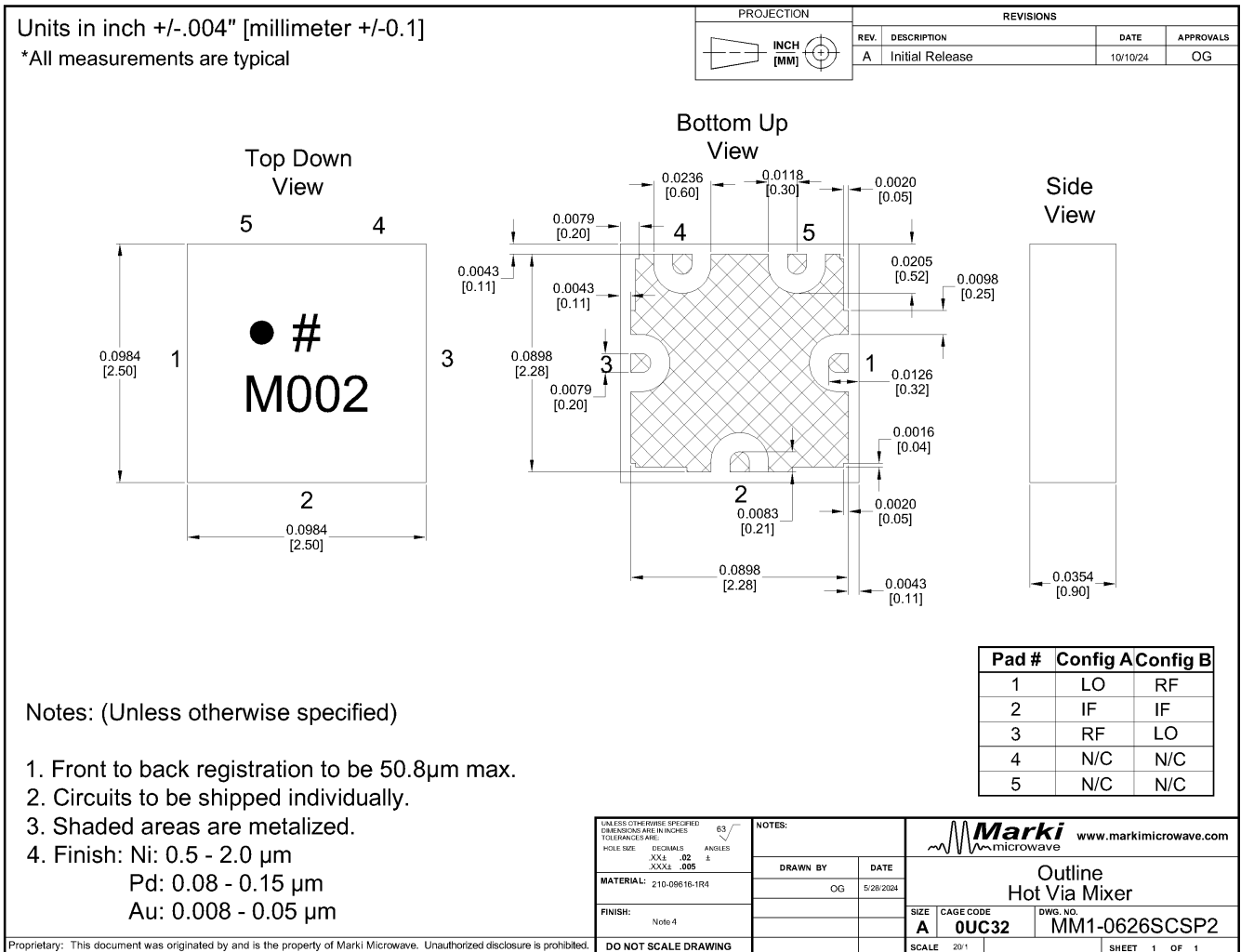

# MM1-0626SCSP2

## GaAs MMIC Chip Scale Package Double Balanced Mixer

### Footprint Image

Download : [Footprint Drawing](#)

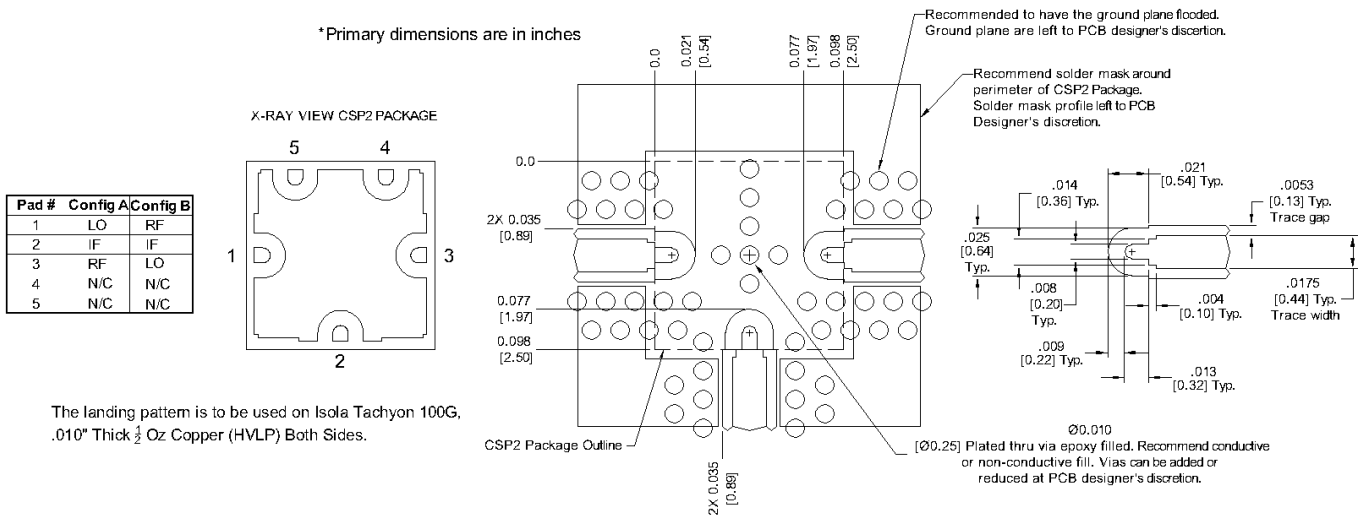

#### DISCLAIMER

MARKI MICROWAVE, LLC., ("MARKI") PROVIDES TECHNICAL SPECIFICATIONS AND DATA (INCLUDING DATASHEETS), APPLICATION OR OTHER DESIGN ADVICE, WEB TOOLS, AND OTHER INFORMATION AND RESOURCES "AS IS" AND WITH ALL FAULTS. MARKI DISCLAIMS ALL WARRANTIES, EXPRESS OR IMPLIED, INCLUDING, WITHOUT LIMITATION, ANY IMPLIED WARRANTIES OF MERCHANTABILITY, FITNESS FOR A PARTICULAR PURPOSE, OR NON-INFRINGEMENT.

These resources are intended for developers skilled in the art designing with Marki products. You are solely responsible for (1) selecting the appropriate products for your application, (2) designing, validating, and testing your application, and (3) ensuring your application meets applicable standards and other requirements. Marki makes no guarantee regarding the suitability of its products for any particular purpose, nor does Marki assume any liability whatsoever arising out of your use or application of any Marki product.

Marki grants you permission to use these resources only for development of an application that uses Marki products. Other reproduction or use of these resources is strictly prohibited. No license is granted to any other Marki intellectual property or to any third-party intellectual property. Marki reserves the right to make changes to the product(s) or information contained herein without notice.

MARKI MICROWAVE and T3 MIXER are trademarks or registered trademarks of Marki Microwave, LLC. All other trademarks used are the property of their respective owners.

© 2024 - 2025, Marki Microwave, LLC