

# MMH-35120HM

## GaAs MMIC Balanced mmWave Harmonic Mixer

### DEVICE OVERVIEW

#### General Description

MMH-35120H is a GaAs MMIC balanced harmonic mixer that features excellent conversion loss, superior isolations, and spurious performance across an incredibly broad bandwidth utilizing the 3rd harmonic of the LO. The MMH-35120H works well as both an up and down converter from the Ka band through mmWave/G band. The MMH-35120H is recommended for mmWave frequency conversion applications where a mmWave LO source may not be available. It is available as both wire bondable die and as a connectorized module.

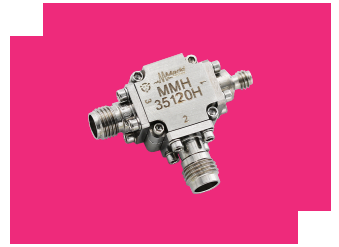

#### Features

- Ultra-broadband, mmWave frequency conversion
- Efficient frequency conversion utilizing 3xLO harmonic
- High LO to RF isolation

#### Applications

- mmWave Frequency Conversion
- Test and Measurement Equipment
- Automotive Radar
- 5G Test Receivers
- mmWave Tuner Mixer

#### Functional Block Diagram

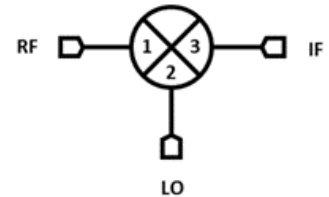

#### Part Ordering Options

Part Number	Description	Package	Connectors	Green Status	Product Lifecycle	Export Classification
MMH-35120HM	GaAs MMIC Balanced mmWave Harmonic Mixer	M	<u>Standard</u>	REACH RoHS	Released	3A001.b.7.c.1

## MMH-35120HM

### GaAs MMIC Balanced mmWave Harmonic Mixer

#### Table Of Contents

##### ■ Device Overview

- General Description
- Features
- Applications
- Functional Block Diagram

##### ■ Port Configuration and Functions

- Port Diagram
- Port Functions

##### ■ Revision History

##### ■ Specifications

- Absolute Maximum Ratings
- Package Information
- Recommended Operating Conditions
- Sequencing Requirements
- Electrical Specifications
- Typical Performance Plots

##### ■ Operation

- Application Information

##### ■ Mechanical Data

- Outline Drawing

#### Revision History

Revision Code	Revision Date	Comment
-	2023-01-01	Datasheet Initial Release



### Port Configuration and Functions

#### Port Diagram

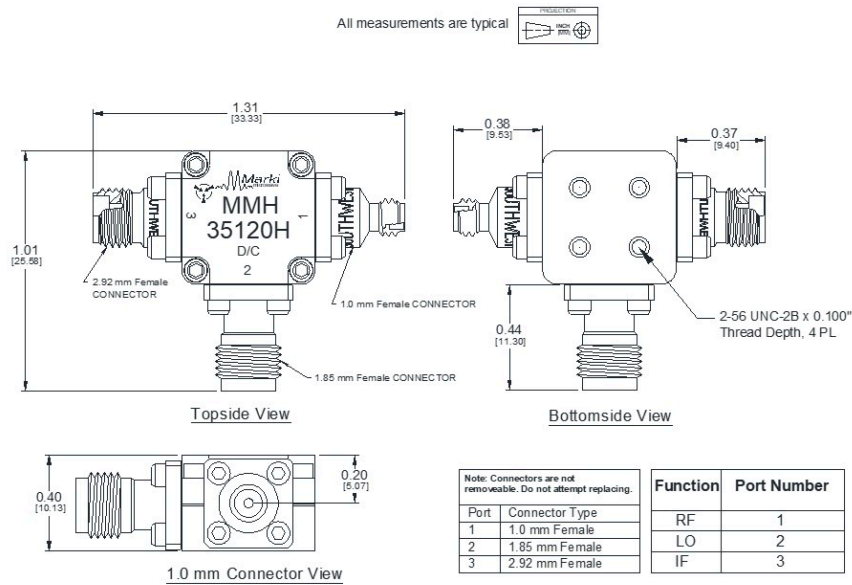
The MMH-35120H has the input and output ports given in Port Functions. The MMH-35120H can be used in either an up or down conversion. For operation, input the LO into port 2, use port 1 for the RF, and port 3 for the IF.

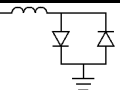
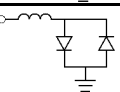

### Port Functions

Port	Function	Connector Type	Description	Equivalent Circuit for Package
GND	Ground	-	M package ground provided through metal housing and outer coax conductor.	<b>GND</b> 
Port 1	RF	1.0F	Port 1 is DC open for the CH and M packages.	<b>P1</b> 
Port 2	LO	1.85F	Port 2 is diode connected for the CH and M package.	<b>P2</b> 
Port 3	IF	2.92F	Port 3 is diode connected for the CH and M package.	<b>P3</b> 

## Specifications

### Absolute Maximum Ratings

The Absolute Maximum Ratings indicate limits beyond which damage may occur to the device. If these limits are exceeded, the device may be inoperable or have a reduced lifetime.

Parameter	Maximum Rating	Unit
Maximum Operating Temperature	100	°C
Maximum Storage Temperature	125	°C
Minimum Operating Temperature	-55	°C
Minimum Storage Temperature	-65	°C
Port 2 DC Current Handling	30	mA
Port 3 DC Current Handling	30	mA

### Package Information

Parameter	Details	Rating
ESD	250 to < 500 Volts	HBM Class 1A
Weight	Package name: M	22g
Dimensions	-	33.33 x 25.58 mm

### Recommended Operating Conditions

The Recommended Operating Conditions indicate the limits, inside which the device should be operated, to guarantee the performance given in Electrical Specifications. Operating outside these limits may not necessarily cause damage to the device, but the performance may degrade outside the limits of the electrical specifications. For limits, above which damage may occur, see Absolute Maximum Ratings.

Parameter	Min	Nominal	Max	Unit
Ambient Temperature	-55	25	100	°C
LO Input Power	13	15	17	dBm

### Sequencing Requirements

There is no requirement to apply power to the ports in a specific order. However, it is recommended to provide a 50Ω termination to each port before applying power. This is a passive diode mixer that requires no DC bias.

### Electrical Specifications

The electrical specifications apply at TA=+25°C in a 50Ω system. Typical data shown is for the connectorized M package mixer used in the forward direction with a +15dBm sine wave LO input. Min and Max limits apply only to our connectorized units and are guaranteed at TA=+25°C. All bare die are 100% DC tested and visually inspected.

Parameter	Test Conditions	Min	Typ	Max	Unit
1x1L Conversion Loss	RF = 35 – 50 GHz LO = 35 – 50 GHz IF = 91 MHz	-	15	-	dB
1x2L Suppression	-	-	22	-	dBc
1x3L Conversion Loss <sup>1</sup>	RF = 35 – 120 GHz LO = 12 – 40 GHz IF = 91 MHz	-	18	-	dB
1x4L Suppression	-	-	30	-	dBc
3LO to RF Isolation	-	-	57	-	dB
IF Frequency Range	-	0	-	14	GHz
Input IP3	-	-	7	-	dBm
IP1dB	-	-	-5	-	dBm
Isolation, LO to RF	-	-	57	-	dB
LO Frequency Range	-	12	-	40	GHz
Noise Figure <sup>2</sup>	RF = 35 – 120 GHz LO = 12 – 40 GHz IF = 91 MHz	-	18.5	-	dB
RF Frequency Range	-	35	-	120	GHz

[1] Measured as a down converter to a fixed 91MHz IF.

[2] Mixer Noise Figure typically measures within 0.5 dB of conversion loss for IF frequencies greater than 5 MHz.

# MMH-35120HM

## GaAs MMIC Balanced mmWave Harmonic Mixer

### Typical Performance Plots

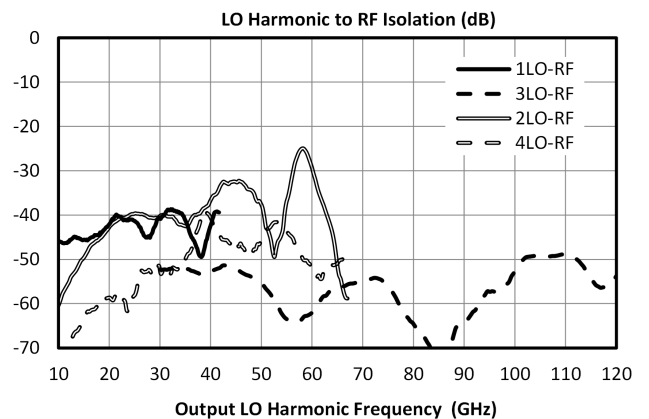
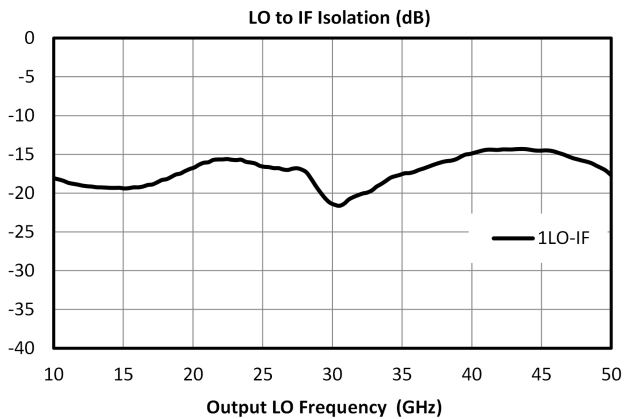
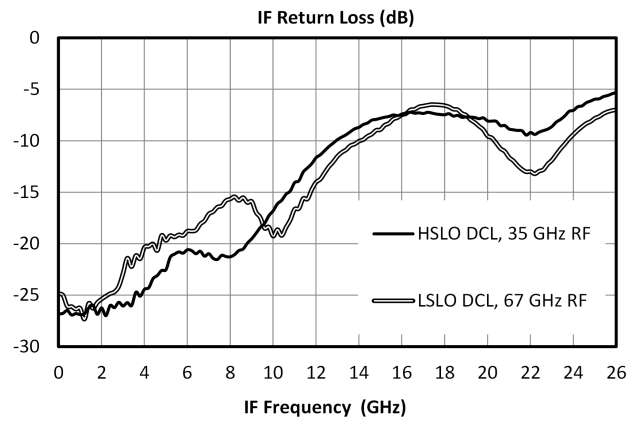
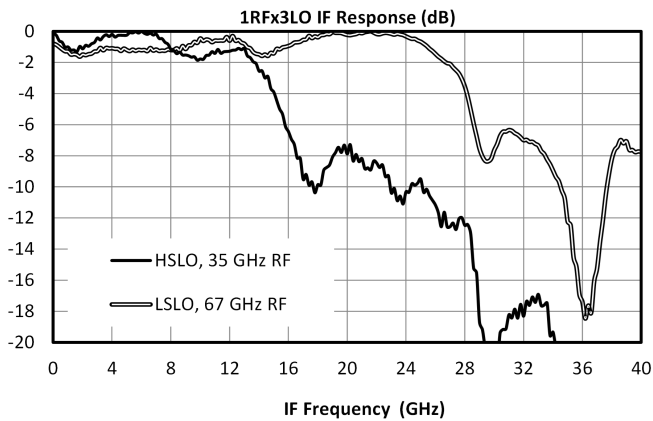
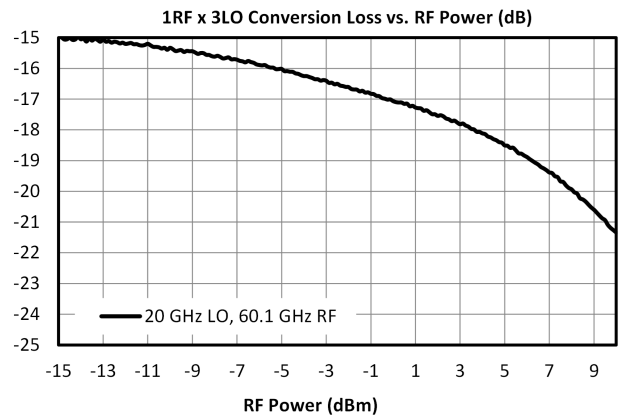
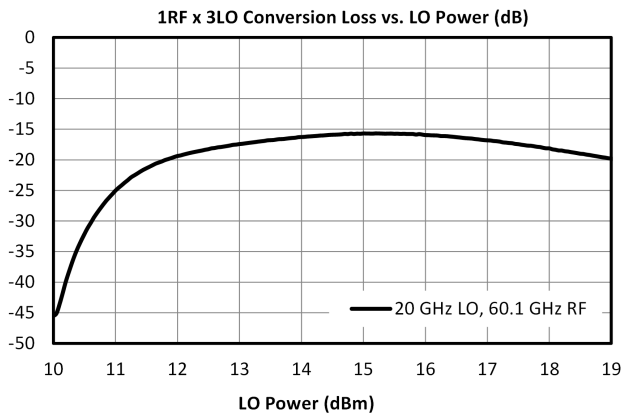
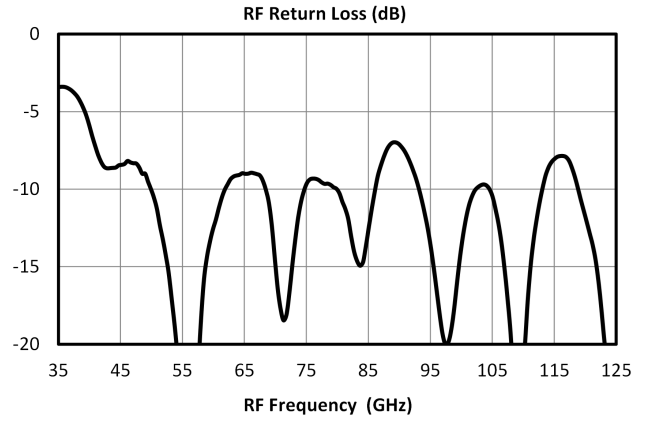
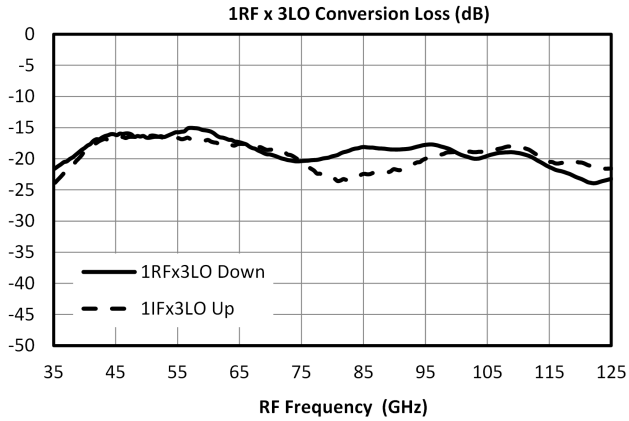

## MMH-35120HM

### GaAs MMIC Balanced mmWave Harmonic Mixer

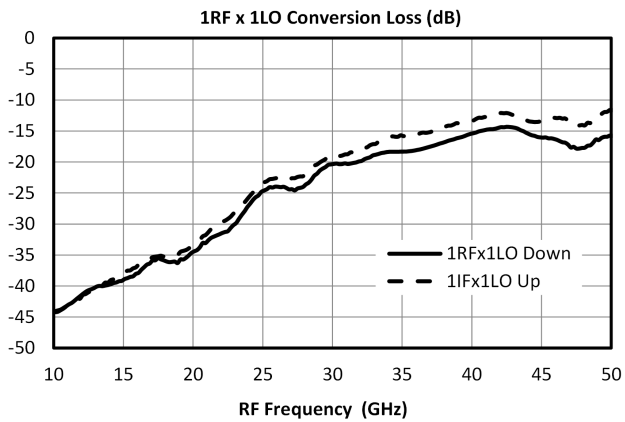
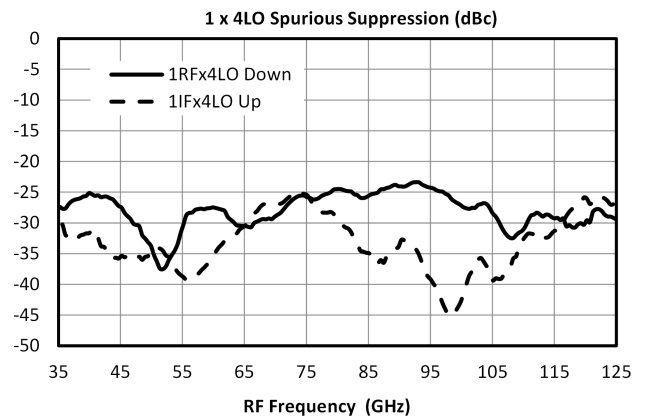
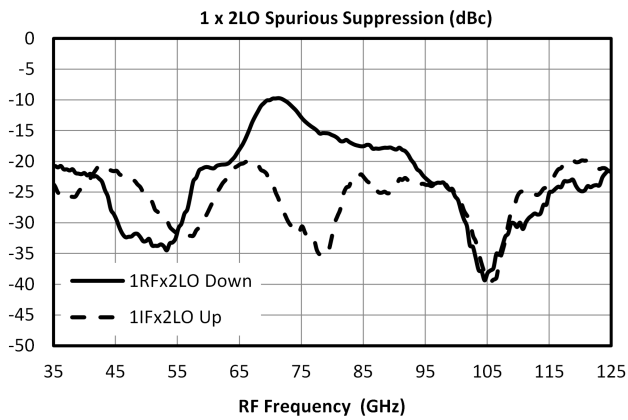
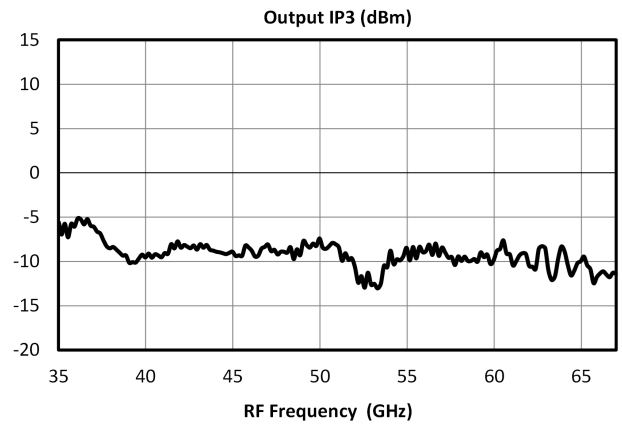
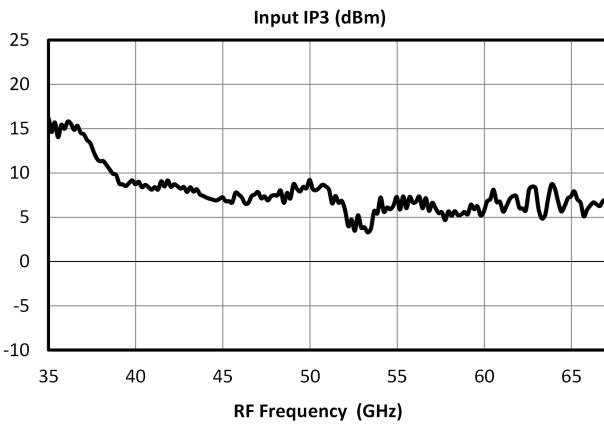

## MMH-35120HM

### GaAs MMIC Balanced mmWave Harmonic Mixer

#### Application Information

#### Typical Operation

The MMH-35120H is a subharmonic mixer meaning the mixer is designed for optimal conversion efficiency of the  $1 \times 3LO$  tone. This means that integrated into the mixer is a  $3x$  multiplier circuit on the LO path so that the user does not need to generate high powered mmWave LO tones. To operate this mixer as an upconverter, inject your small signal input into port 3 (IF port) and select an LO tone to inject into port 2 (LO port) such that the output tone will be at a frequency of  $1IF+3LO$  on port 1 (RF port). Likewise, to operate this mixer as a downconverter one should inject their small signal mmWave tone into port 1 (RF port), and select an LO tone for port 2 (LO port) such that the down converted tone is at  $1RF-3LO$  or  $3LO-1RF$  on port 3 (IF port).

## MMH-35120HM

### GaAs MMIC Balanced mmWave Harmonic Mixer

#### Mechanical Data

#### Outline Drawing

Download : [Outline 3D Drawing](#) | [Outline 3D STP](#)

All measurements are typical

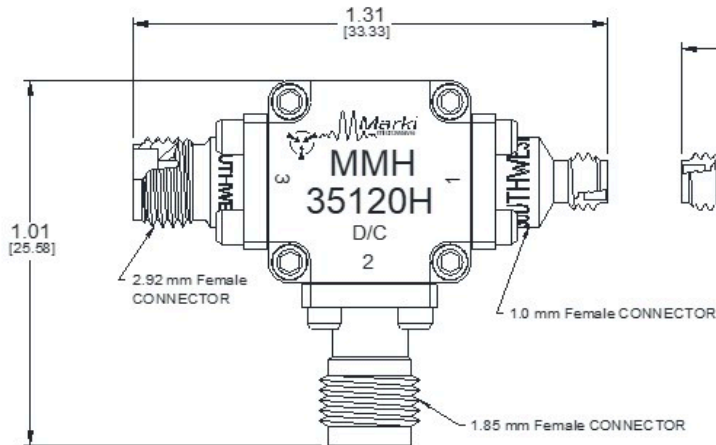

Topside View

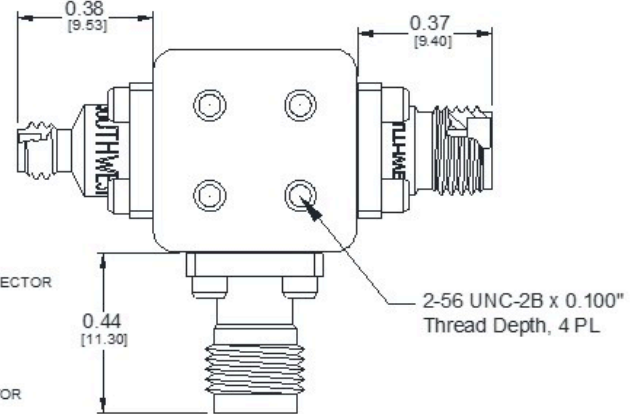

Bottomside View

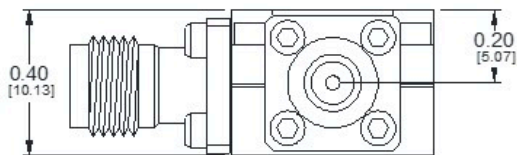

1.0 mm Connector View

Note: Connectors are not removable. Do not attempt replacing.

Port	Connector Type
1	1.0 mm Female
2	1.85 mm Female
3	2.92 mm Female

Function	Port Number
RF	1
LO	2
IF	3

1. All measurements are typical.
2. Attach 1.0mm connectors with 45 N-cm (4 in-lb) torque wrench.

#### DISCLAIMER

MARKI MICROWAVE, INC., ("MARKI") PROVIDES TECHNICAL SPECIFICATIONS AND DATA (INCLUDING DATASHEETS), APPLICATION OR OTHER DESIGN ADVICE, WEB TOOLS, AND OTHER INFORMATION AND RESOURCES "AS IS" AND WITH ALL FAULTS. MARKI DISCLAIMS ALL WARRANTIES, EXPRESS OR IMPLIED, INCLUDING, WITHOUT LIMITATION, ANY IMPLIED WARRANTIES OF MERCHANTABILITY, FITNESS FOR A PARTICULAR PURPOSE, OR NON-INFRINGEMENT.

These resources are intended for developers skilled in the art designing with Marki products. You are solely responsible for (1) selecting the appropriate products for your application, (2) designing, validating, and testing your application, and (3) ensuring your application meets applicable standards and other requirements. Marki makes no guarantee regarding the suitability of its products for any particular purpose, nor does Marki assume any liability whatsoever arising out of your use or application of any Marki product.

Marki grants you permission to use these resources only for development of an application that uses Marki products. Other reproduction or use of these resources is strictly prohibited. No license is granted to any other Marki intellectual property or to any third-party intellectual property. Marki reserves the right to make changes to the product(s) or information contained herein without notice.

MARKI MICROWAVE and T3 MIXER are trademarks or registered trademarks of Marki Microwave, Inc. All other trademarks used are the property of their respective owners.

© 2023, Marki Microwave, Inc