

HLM-100001PSM

High Power DC - 10GHz Limiter

DEVICE OVERVIEW

General Description

The HLM-100001PSM is a high-power GaAs Schottky diode signal limiter featuring high IP3 over a broad DC-10GHz bandwidth. It offers low insertion loss and excellent return loss from DC through X band and has a typical 1 dB compression point of 11 dBm. Its high power handling makes it ideal for protecting sensitive components and for applications requiring high linearity. It is available as a plastic surface mount QFN or as a connectorized evaluation board.

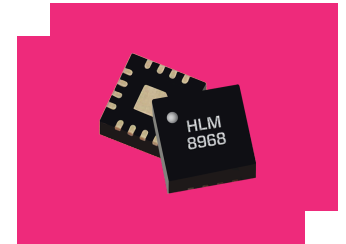

[Download s-parameters here](#)

Features

- Low 0.9dB loss at 5 GHz
- +8.5 to +11.5 dBm Flat Leakage
- Typical P1dB of +11 dBm
- Small signal S2P data available

Applications

- RF Transceivers
- Test and Measurement Equipment
- SATCOM
- Aerospace and Defense

Functional Block Diagram

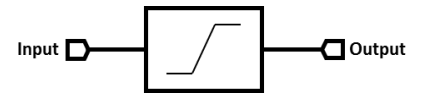

Part Ordering Options

Part Number	Description	Package	Green Status	Product Lifecycle	Export Classification
HLM-100001PSM	High Power DC - 10GHz Limiter	QFN	REACH RoHS	Released	EAR99
EVB-HLM-100001P	Evaluation Board, High Power DC - 10GHz Limiter	EVB	REACH RoHS	Released	EAR99

Table Of Contents

- **Device Overview**
 - General Description
 - Features
 - Applications
 - Functional Block Diagram
- **Port Configuration and Functions**
 - Port Diagram
 - Port Functions
- **Revision History**
- **Specifications**
 - Absolute Maximum Ratings
 - Package Information
 - Electrical Specifications
 - Typical Performance Plots
 - Typical Performance Plots EVB Package
- **Operation**
 - Application Information
 - Application Circuit
 - Application Circuit Description
- **Mechanical Data**
 - Outline Drawing
- **Footprint Image**
- **Evaluation Board**
 - Evaluation Board Outline Drawing

Revision History

Revision Code	Revision Date	Comment
-	2024-03-28	Datasheet Initial Release

Port Configuration and Functions

Port Diagram

A bottom-up view of the HLM-100001PSM's package outline drawing is shown below. The HLM-100001PSM has the input and output ports given in Port Functions.

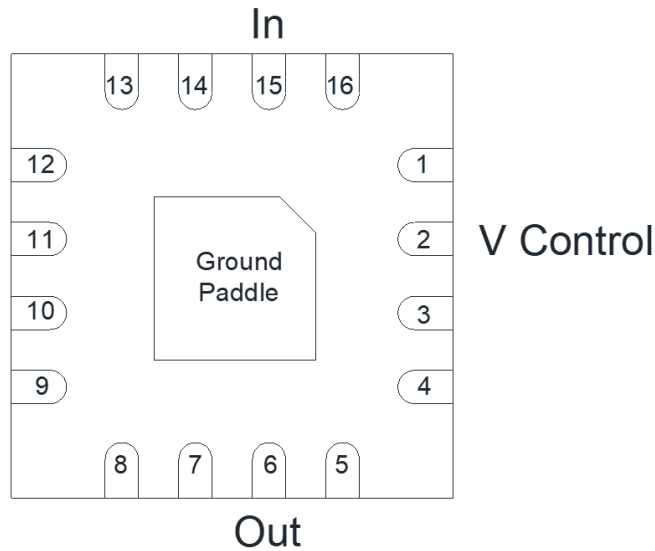

Port Functions

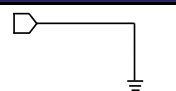
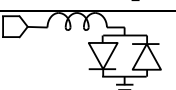
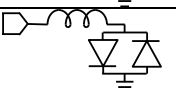
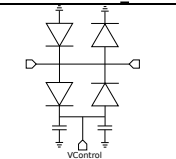
Port	Function	Description	DC Equivalent Circuit
Ground Paddle	Ground	PSM package ground path is provided through the ground paddle and should be connected to RF ground	
IN	Input	Pin 15 is the RF input port and is diode connected for the PSM and EVB package.	
OUT	Output	Pin 6 is the RF output port and is diode connected for the PSM and EVB package.	
VCONTROL	V Control	A 10Ω resistor with at least a 30 mA current rating must be used in series with Pin 2 and tied to ground for normal operation.	

Specifications

Absolute Maximum Ratings

The Absolute Maximum Ratings indicate limits beyond which damage may occur to the device. If these limits are exceeded, the device may be inoperable or have a reduced lifetime.

Parameter	Maximum Rating	Unit
Maximum Operating Temperature	100	°C
Maximum Storage Temperature	125	°C
Minimum Operating Temperature	-55	°C
Minimum Storage Temperature	-65	°C
MSL	1	-
RF Power Handling , Average ¹	10	W
θ_{JC} , Junction to Ambient Thermal Resistance	39	°C/W

RF Power Handling represents an instantaneous, catastrophic limit and it isn't derated for frequency, temperature, pulse conditions, or unit to unit variation.

[1] CW @ 10 GHz, 25°C

Package Information

Parameter	Details	Rating
Dimensions	-	3 x 3 mm
Moisture Sensitivity Level	-	MSL 1

Electrical Specifications

The electrical specifications apply at TA=+25°C in a 50Ω system. Typical data shown is for the EVB package limiter unless otherwise specified. Linear Specifications valid for input power up to the 0.1dB compression point. See typical performance plots EVB Package for P0.1dB graph. Min and Max limits are guaranteed at TA=+25°C.

Parameter	Test Conditions	Minimum Frequency (GHz)	Maximum Frequency (GHz)	Min	Typ	Max	Unit
Flat Leakage	-	10	10	-	8.5	-	dBm
Input IP3	-	0	10	-	27	-	dBm
Input P1dB	-	0	10	-	11	-	dBm
Insertion Loss ¹	-	0	10	-	0.9	1.5	dB
Return Loss ²	-	0	10	-	22	-	dB
Flat Leakage	-	2	2	-	11.5	-	dBm

^{[1][2]} De-embedded from fixture using AFR.

Typical Performance Plots

Typical Performance Plots measured data is de-embedded from fixture using AFR.

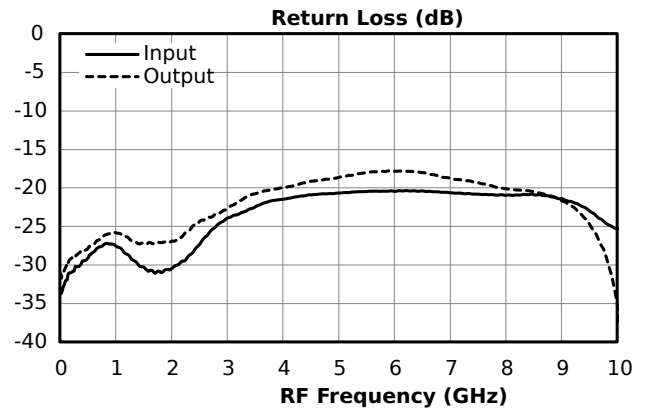
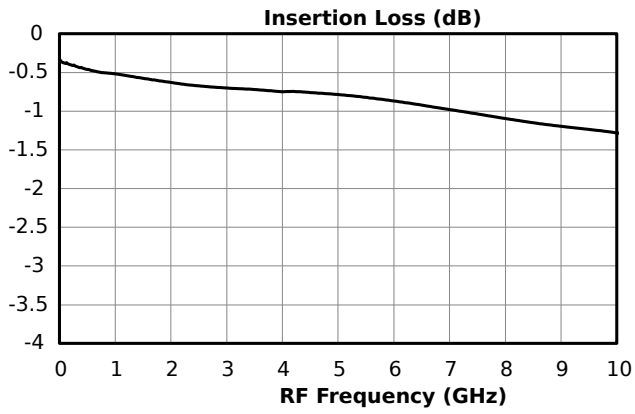

Typical Performance Plots EVB Package

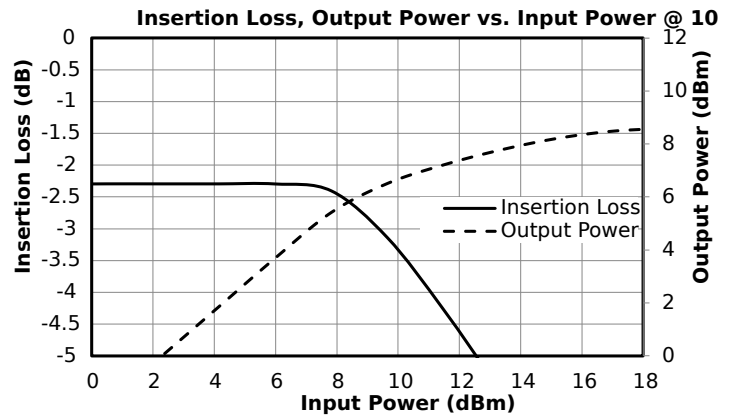
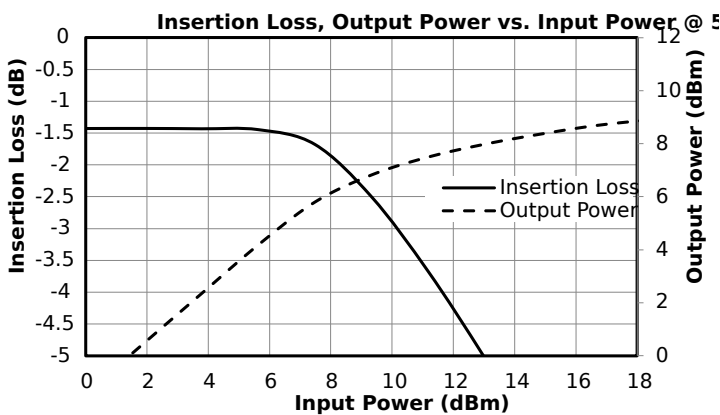
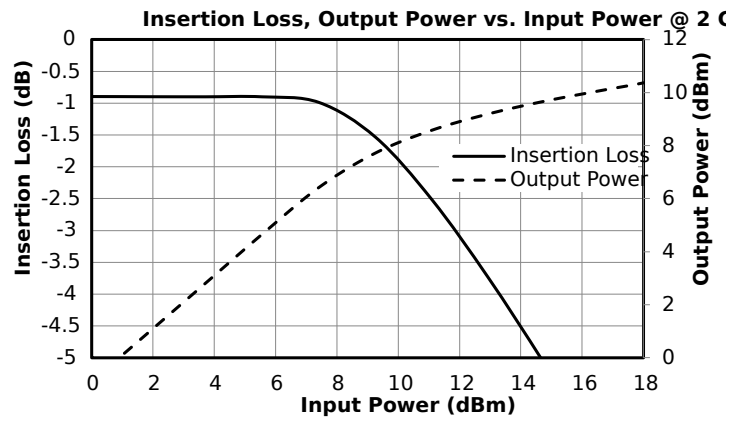
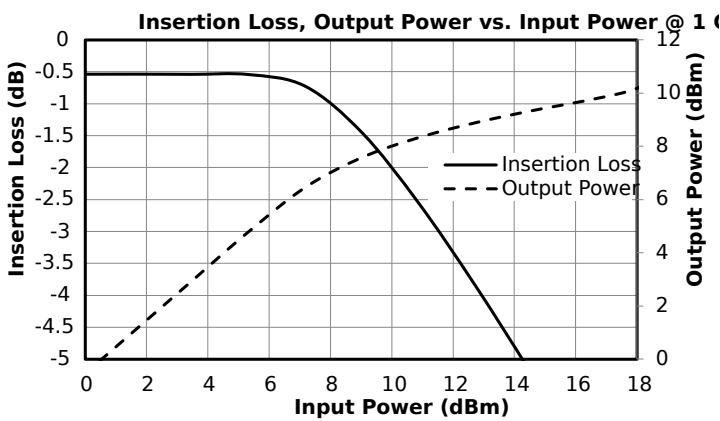
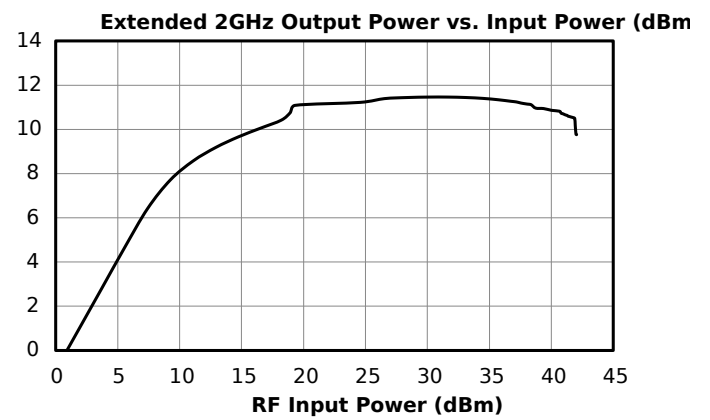
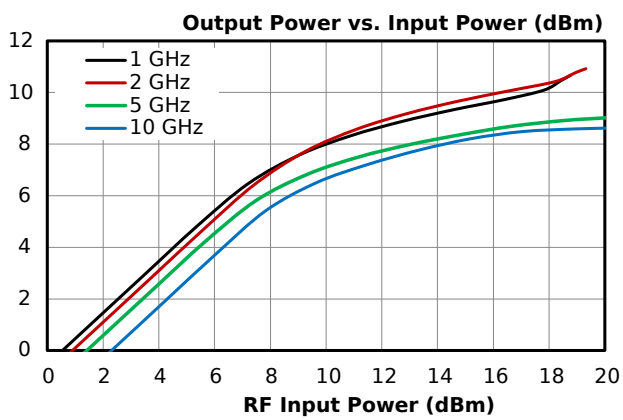
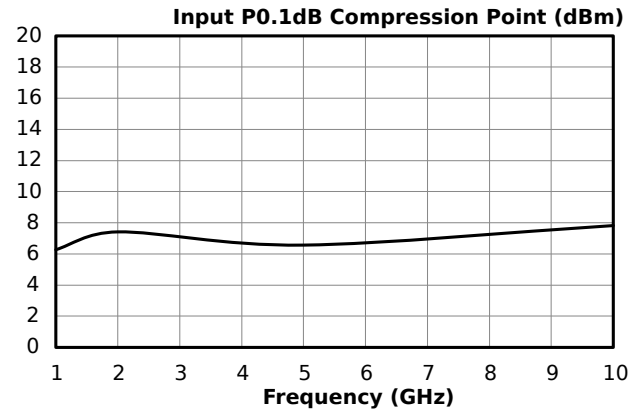
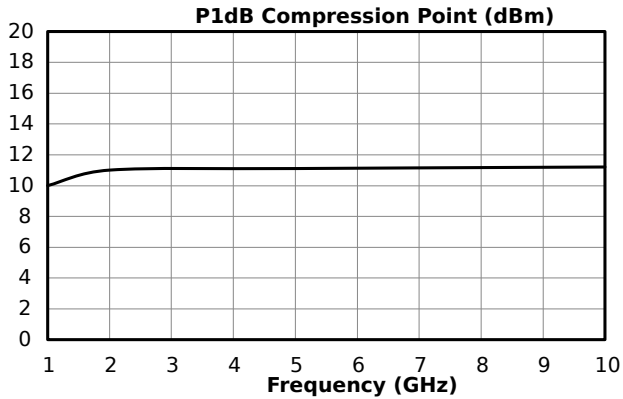

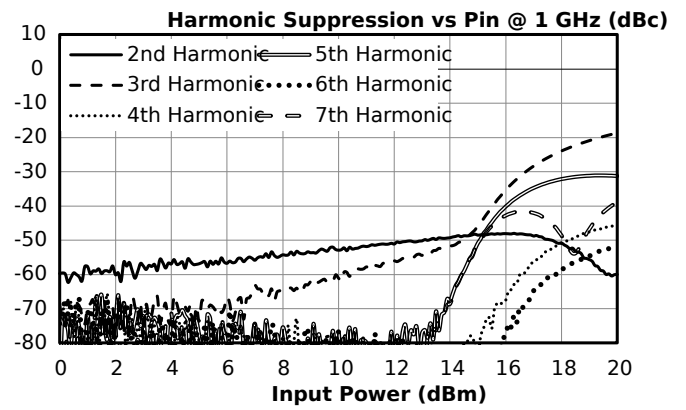
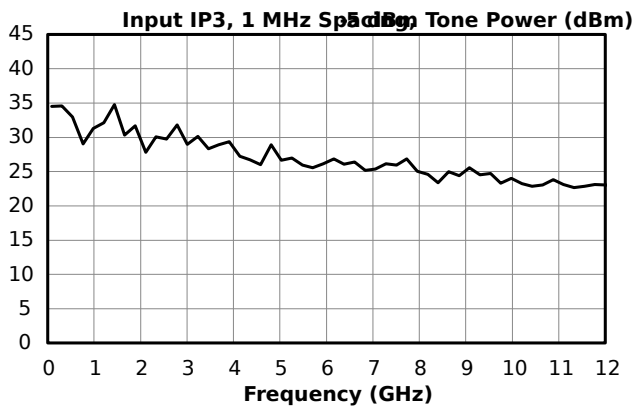
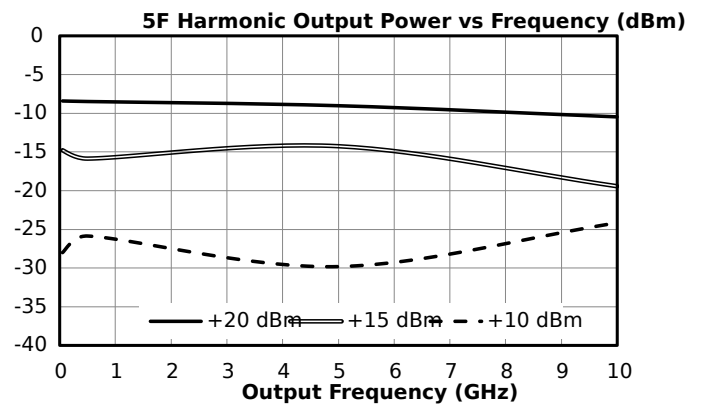
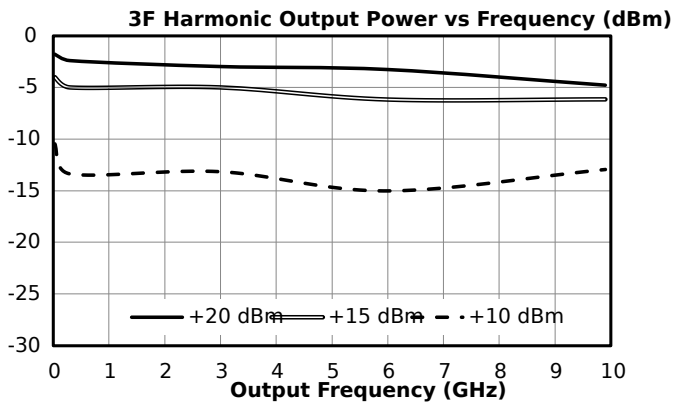

Application Information

Below is the application circuit for the HLM-100001PSM.

Application Circuit

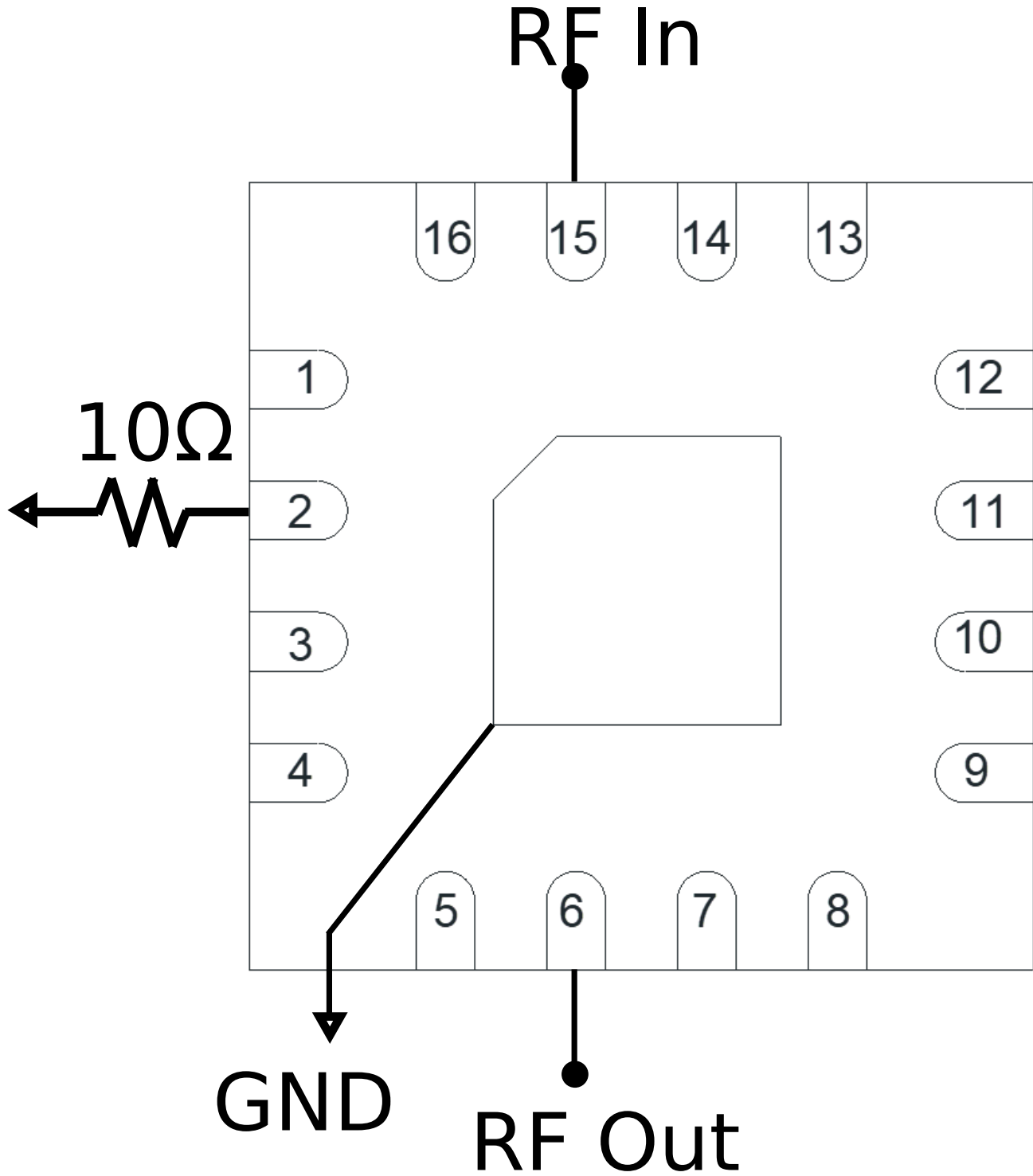

Application Circuit Description

For normal operation, a 10Ω resistor with at least a 30 mA current rating must be used in series with the VCONTROL pin and tied to ground. Operation without a resistor will causes resonances.

Mechanical Data

Outline Drawing

Download : [Outline 2D Drawing](#) | [Outline 3D Drawing](#) | [Outline 3D STP](#)

Units are in inches [mm]

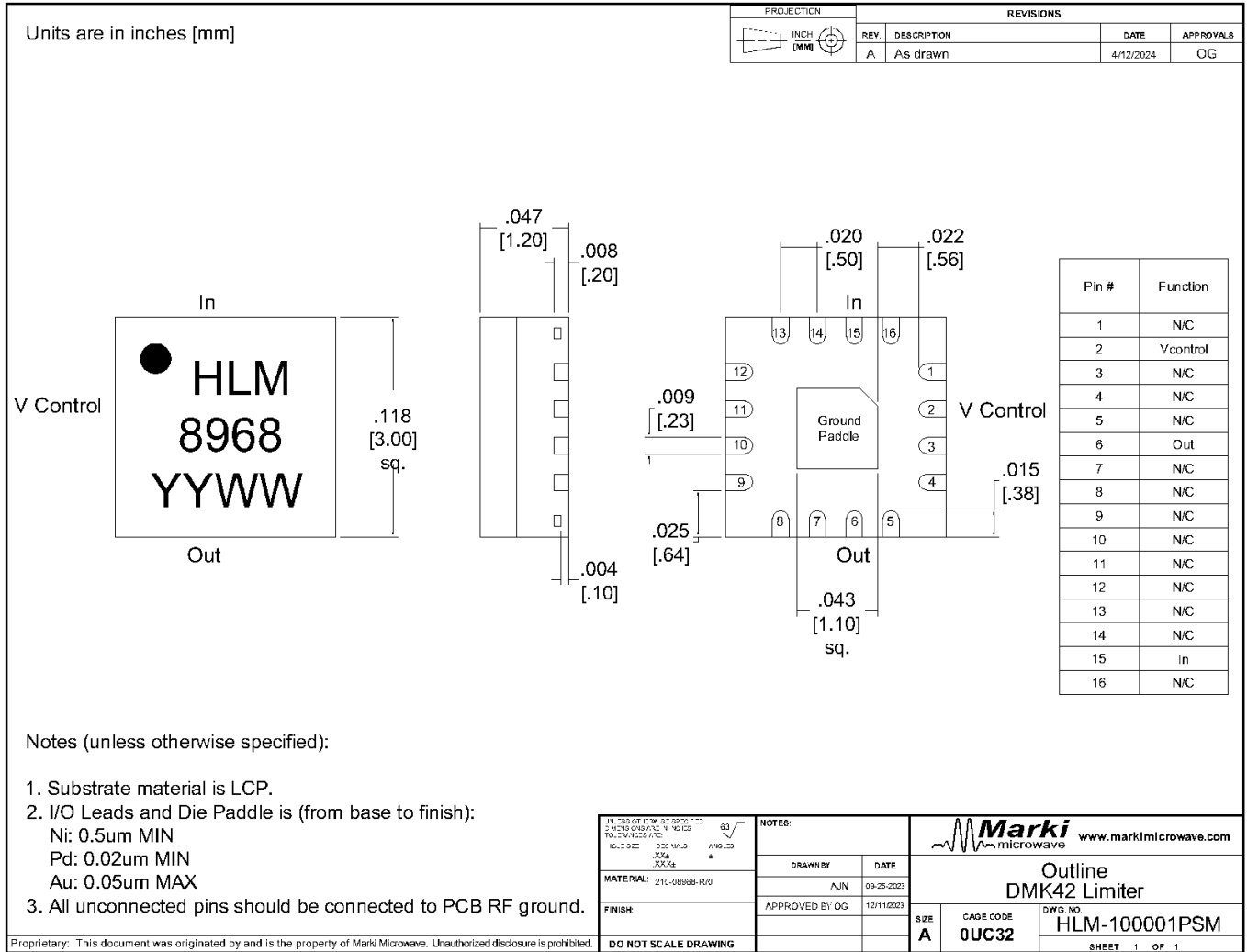

PROJECTION		REVISIONS			
INCH	[MM]	REV.	DESCRIPTION	DATE	APPROVALS
		A	As drawn	4/12/2024	OG

Pin #	Function
1	N/C
2	Vcontrol
3	N/C
4	N/C
5	N/C
6	Out
7	N/C
8	N/C
9	N/C
10	N/C
11	N/C
12	N/C
13	N/C
14	N/C
15	In
16	N/C

Notes (unless otherwise specified):

- Substrate material is LCP.
- I/O Leads and Die Paddle is (from base to finish):
Ni: 0.5um MIN
Pd: 0.02um MIN
Au: 0.05um MAX
- All unconnected pins should be connected to PCB RF ground.

<small>JUL 2023 QTY: 10,000 82 9950 1-22 S/N: 10 045 045 1 1 10 023 TOL: 0.005 0.005 0.005</small>		NOTES: DRAWN BY: AJN DATE: 09-25-2023 APPROVED BY: OG DATE: 12/11/2023		 www.markimicrowave.com	
MATERIAL: 210-08988-R/0		FINISH:		Outline DMK42 Limiter	
DO NOT SCALE DRAWING		SIZE A		CAGE CODE 0UC32	
				DWG. NO. HLM-100001PSM	
				SHEET 1 OF 1	

Proprietary: This document was originated by and is the property of Marki Microwave. Unauthorized disclosure is prohibited.

Footprint Image

Download : [Footprint Drawing](#)

Pin #	Function
1	N/C
2	Vcontrol
3	N/C
4	N/C
5	N/C
6	Out
7	N/C
8	N/C
9	N/C
10	N/C
11	N/C
12	N/C
13	N/C
14	N/C
15	In
16	N/C

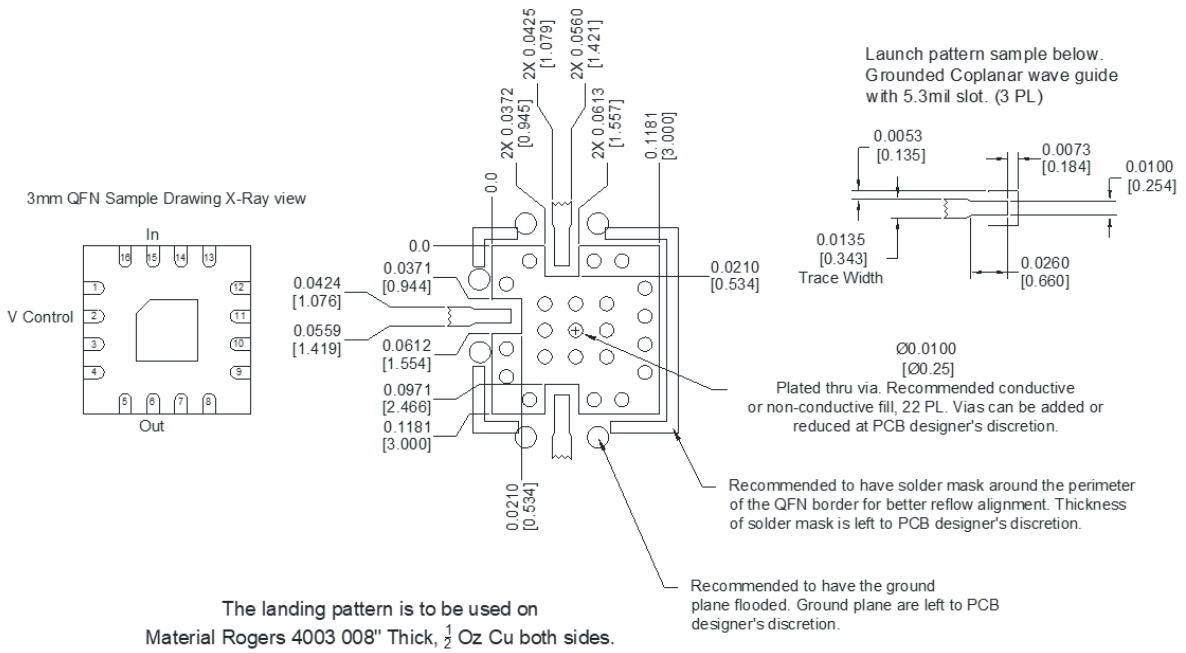

Evaluation Board - Outline Drawing

*All Dimensions are typical!

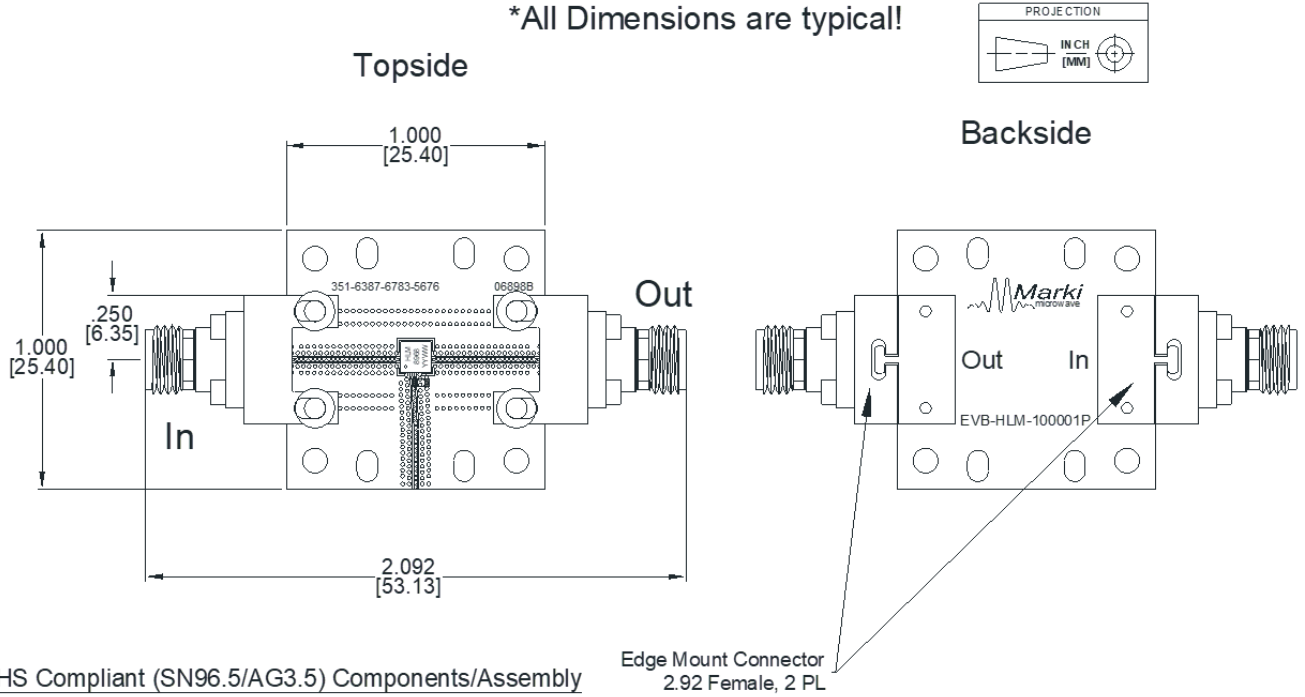

RoHS Compliant (SN96.5/AG3.5) Components/Assembly

Edge Mount Connector
 2.92 Female, 2 PL

DISCLAIMER

MARKI MICROWAVE, LLC., ("MARKI") PROVIDES TECHNICAL SPECIFICATIONS AND DATA (INCLUDING DATASHEETS), APPLICATION OR OTHER DESIGN ADVICE, WEB TOOLS, AND OTHER INFORMATION AND RESOURCES "AS IS" AND WITH ALL FAULTS. MARKI DISCLAIMS ALL WARRANTIES, EXPRESS OR IMPLIED, INCLUDING, WITHOUT LIMITATION, ANY IMPLIED WARRANTIES OF MERCHANTABILITY, FITNESS FOR A PARTICULAR PURPOSE, OR NON-INFRINGEMENT.

These resources are intended for developers skilled in the art designing with Marki products. You are solely responsible for (1) selecting the appropriate products for your application, (2) designing, validating, and testing your application, and (3) ensuring your application meets applicable standards and other requirements. Marki makes no guarantee regarding the suitability of its products for any particular purpose, nor does Marki assume any liability whatsoever arising out of your use or application of any Marki product.

Marki grants you permission to use these resources only for development of an application that uses Marki products. Other reproduction or use of these resources is strictly prohibited. No license is granted to any other Marki intellectual property or to any third-party intellectual property. Marki reserves the right to make changes to the product(s) or information contained herein without notice.

MARKI MICROWAVE and T3 MIXER are trademarks or registered trademarks of Marki Microwave, LLC. All other trademarks used are the property of their respective owners.

© 2024, Marki Microwave, LLC