

MBAL-0220CSP2

2-20 GHz Passive MMIC Chip Scale Package Balun

DEVICE OVERVIEW

General Description

The MBAL-0220CSP2 is a GaAs passive MMIC balun featuring a frequency range of 2 to 20 GHz. This balun offers low 1.9 dB insertion loss as a mode converter, excellent balance and 27 dB common mode rejection in a compact 2.5 mm CSP2 chip scale package. The leadfree, RoHS compliant CSP2 package is compatible with standard pick and place assembly. It is an ideal solution to interface into dataconverters for S-K band digital beamforming and other higher order Nyquist sampling applications, clock distribution, and balanced amplifiers.

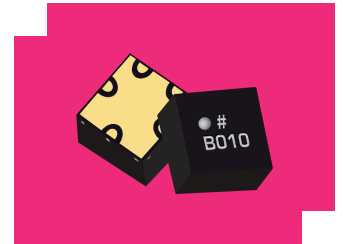

[Download s-parameters here](#)

Features

- 2:1 Impedance Ratio
- 2 to 20 GHz Balun (Balanced to Unbalanced Transformer)
- Insertion Loss as a Mode Converter, 1.9 dB Typical
- Common Mode Rejection, 27 dB Typical
- Phase/Amplitude Balance, 3° and 0.3 dB Typical
- 2.5 x 2.5 mm Package
- This product embodies Marki Microwave's U.S. Pat. 11,869,858.

Applications

- Balanced Receivers
- Signal Integrity
- Analog to Digital Converters
- Balanced Amplifiers
- Clock Distribution

Functional Block Diagram

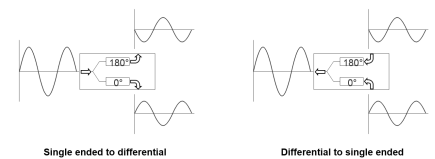

Part Ordering Options

Part Number	Description	Package	Packing Size	Green Status	Product Lifecycle	Export Classification
MBAL-0220CSP2	2-20 GHz Passive MMIC Chip Scale Package Balun	CSP2	-	REACH RoHS	Released	EAR99
EVB-MBAL-0220	Evaluation Board, 2-20 GHz Passive MMIC Chip Scale Package Balun	EVB	-	REACH RoHS	Released	EAR99
MBAL-0220CSP-TR	Tape and Reel, 2-20 GHz Passive MMIC Chip Scale Package Balun	CSP2	13"	REACH RoHS	Released	EAR99

MBAL-0220CSP2

2-20 GHz Passive MMIC Chip Scale Package Balun

Table Of Contents

■ Device Overview

General Description
Features
Applications
Functional Block Diagram

■ Port Configuration and Functions

Port Diagram
Port Functions

■ Revision History

■ Specifications

Absolute Maximum Ratings
Package Information
Electrical Specifications
Mixed Mode Scattering Parameters
Typical Performance Scattering Parameters

■ Mechanical Data

Outline Drawing

■ Footprint Image

■ Evaluation Board

Evaluation Board - Performance Data
Evaluation Board Outline Drawing

Revision History



Revision Code	Revision Date	Comment
-	2024-02-28	Datasheet Initial Release
A	2024-10-15	Updated ESD information
B	2025-04-28	Updated Moisture Sensitivity from MSL3 to MSL1

Port Configuration and Functions

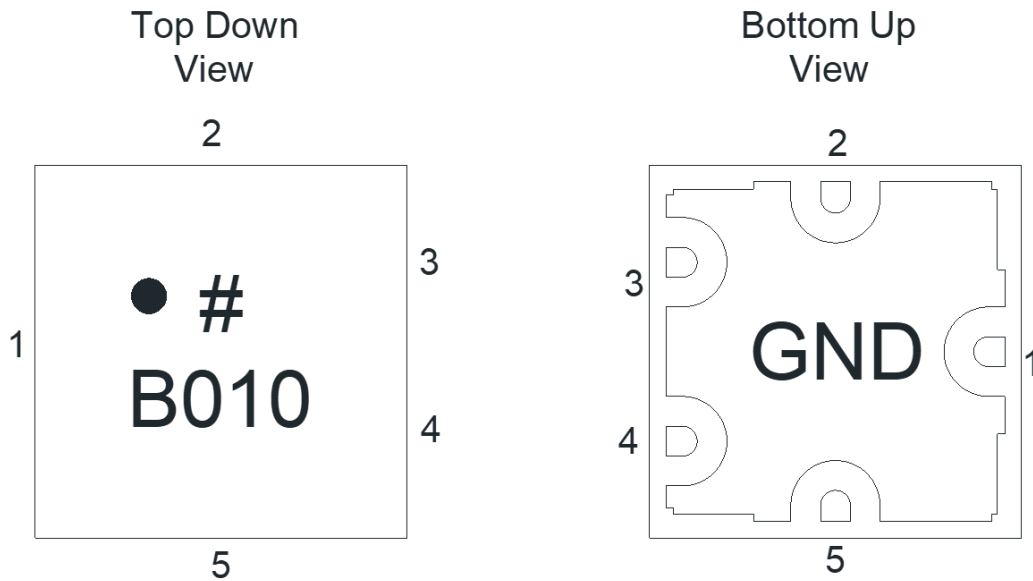
Port Diagram

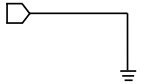
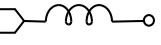
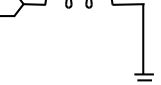
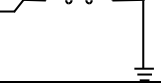

Port Functions

Port	Function	Description	DC Equivalent Circuit
GND	Ground	Ground pad should be connected to RF/DC ground with low electrical and thermal resistance.	
Pin 1	Common Port / In (Unbalanced)	The common port is DC open to ground.	
Pin 3	Out 1 / 0° Port (Balanced)	The 0° port is DC short to ground.	
Pin 4	Out 2 / 180° Port (Balanced)	The 180° port is DC short to ground.	
Pins 2,5	NC	Pins 2 and 5 are not internally connected. They can be connected to ground for normal operation.	

Specifications

Absolute Maximum Ratings

Parameter	Maximum Rating	Unit
Maximum Operating Temperature	100	°C
Maximum Storage Temperature	125	°C
Minimum Operating Temperature	-55	°C
Minimum Storage Temperature	-65	°C
RF Power Handling	36	dBm

Package Information

Parameter	Details	Rating
ESD	250 to < 500 Volts	HBM Class 1A
Dimensions	-	2.50 x 2.50 mm
Moisture Sensitivity Level	-	MSL 1

MBAL-0220CSP2

2-20 GHz Passive MMIC Chip Scale Package

Balun

Electrical Specifications

Parameter	Test Conditions	Minimum Frequency (GHz)	Maximum Frequency (GHz)	Min	Typ	Max	Unit
Output Return Loss	-	2	20	-	7	-	dB
Amplitude Balance	-	2	20	-	0.3	1	dB
Common Mode Rejection	-	2	20	20	27	-	dB
Common Port Return Loss	-	2	20	-	13	-	dB
Impedance	-	2	20	-	50	-	Ω
Impedance Ratio	-	-	-	-	2:1	-	
Insertion Loss as a Mode Converter	-	3	20	-	1.9	4	dB
Insertion Loss as a Mode Converter	-	2	3	-	1.4	6	dB
Isolation between differential ports	-	2	20	-	5.3	-	dB
Nominal Phase Shift	-	2	20	-	180	-	°
Phase Balance	-	2	20	-	3	10	°

Mixed Mode Scattering Parameters

Mixed mode scattering parameters are used to characterize differential circuits. For baluns, this means that the 0° and 180° ports become a single 100Ω differential port and the common port remains the same 50Ω common port. The two-port s-parameters of the balun are then characterized based on differential (d), common mode (c), or single-ended (s) signals. For example: S_{cs12} is the Common output response given a single ended input.

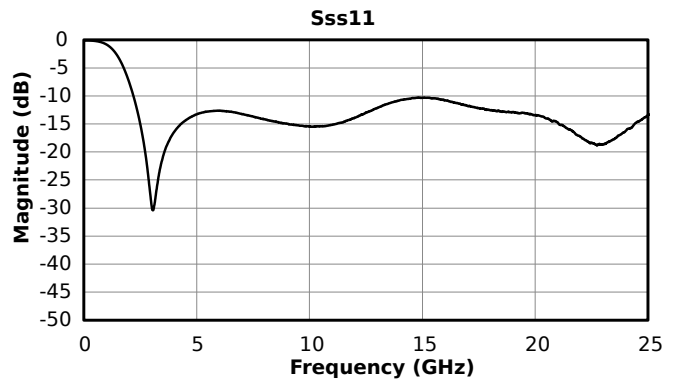
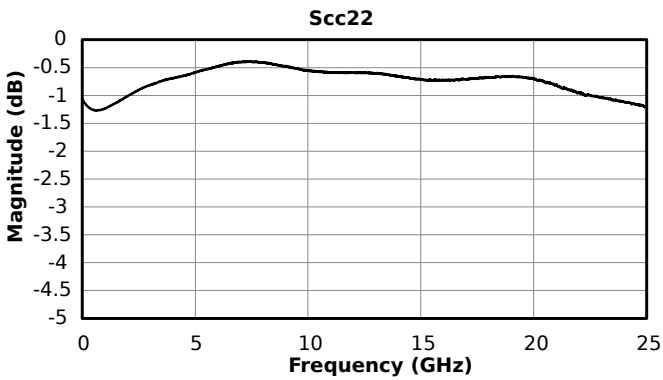
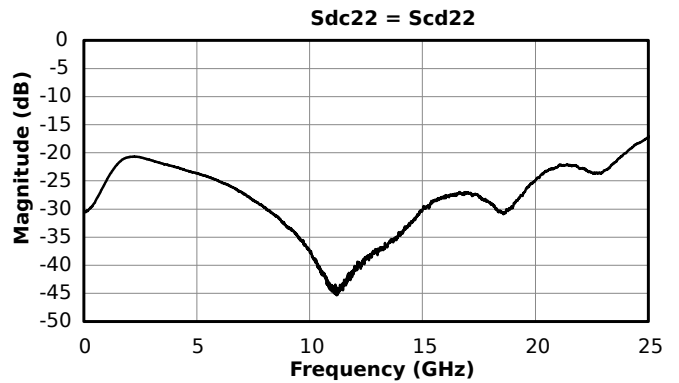
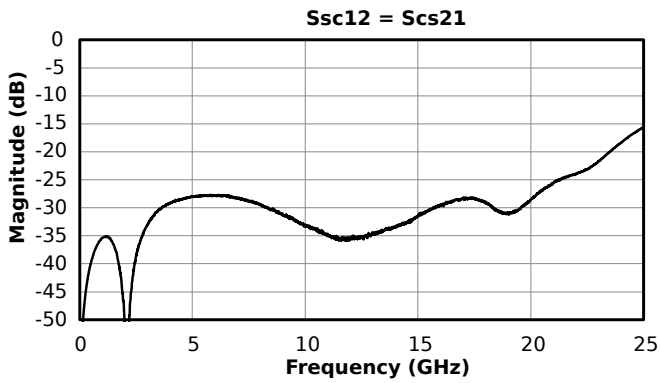
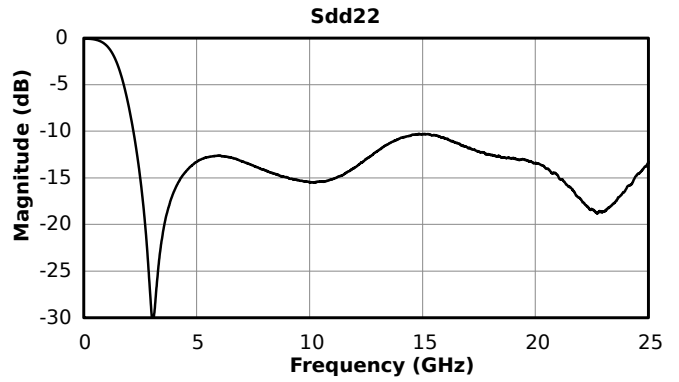
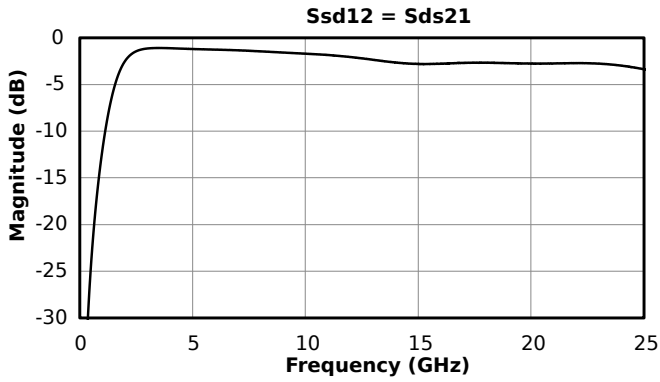

Typical Performance Scattering Parameters

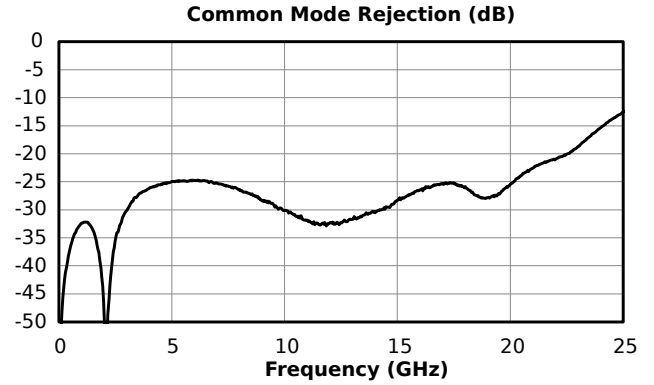
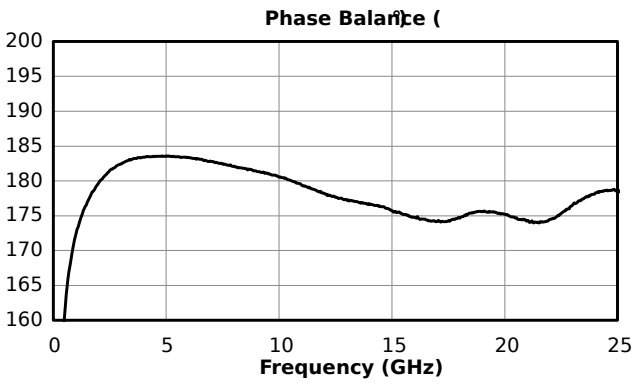
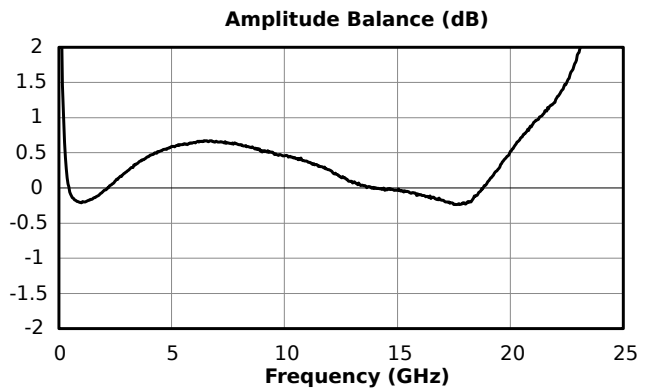
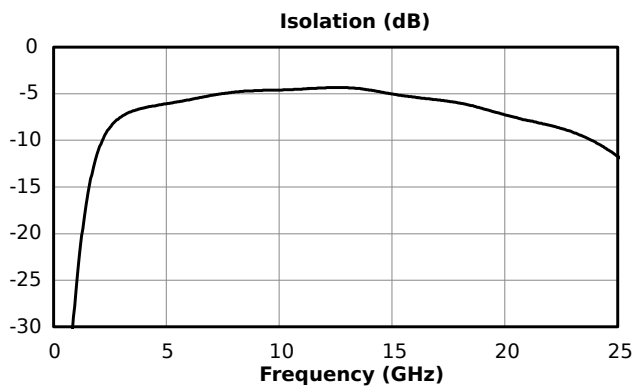
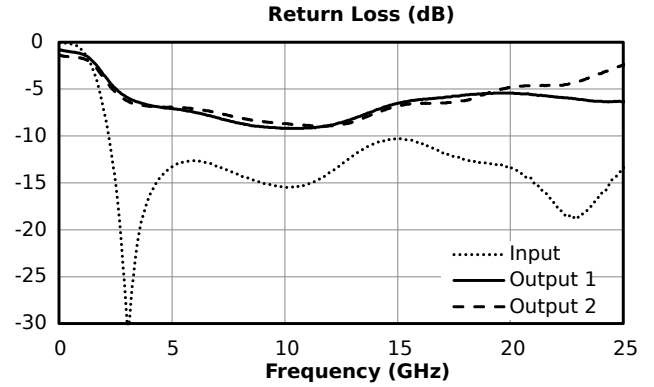
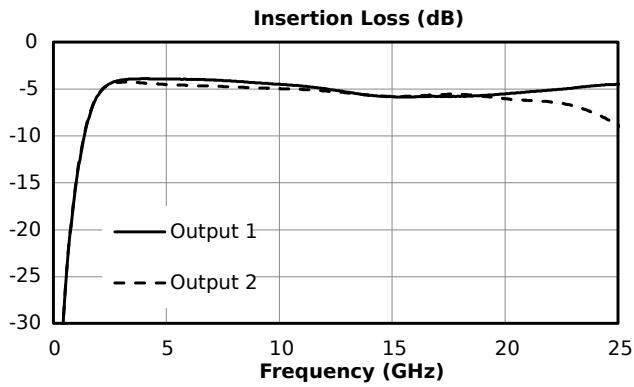

Measured data is de-embedded from fixture using AFR.

Mechanical Data

Outline Drawing

Download : [Outline 2D Drawing](#) | [Outline 3D Drawing](#) | [Outline 3D STP](#)

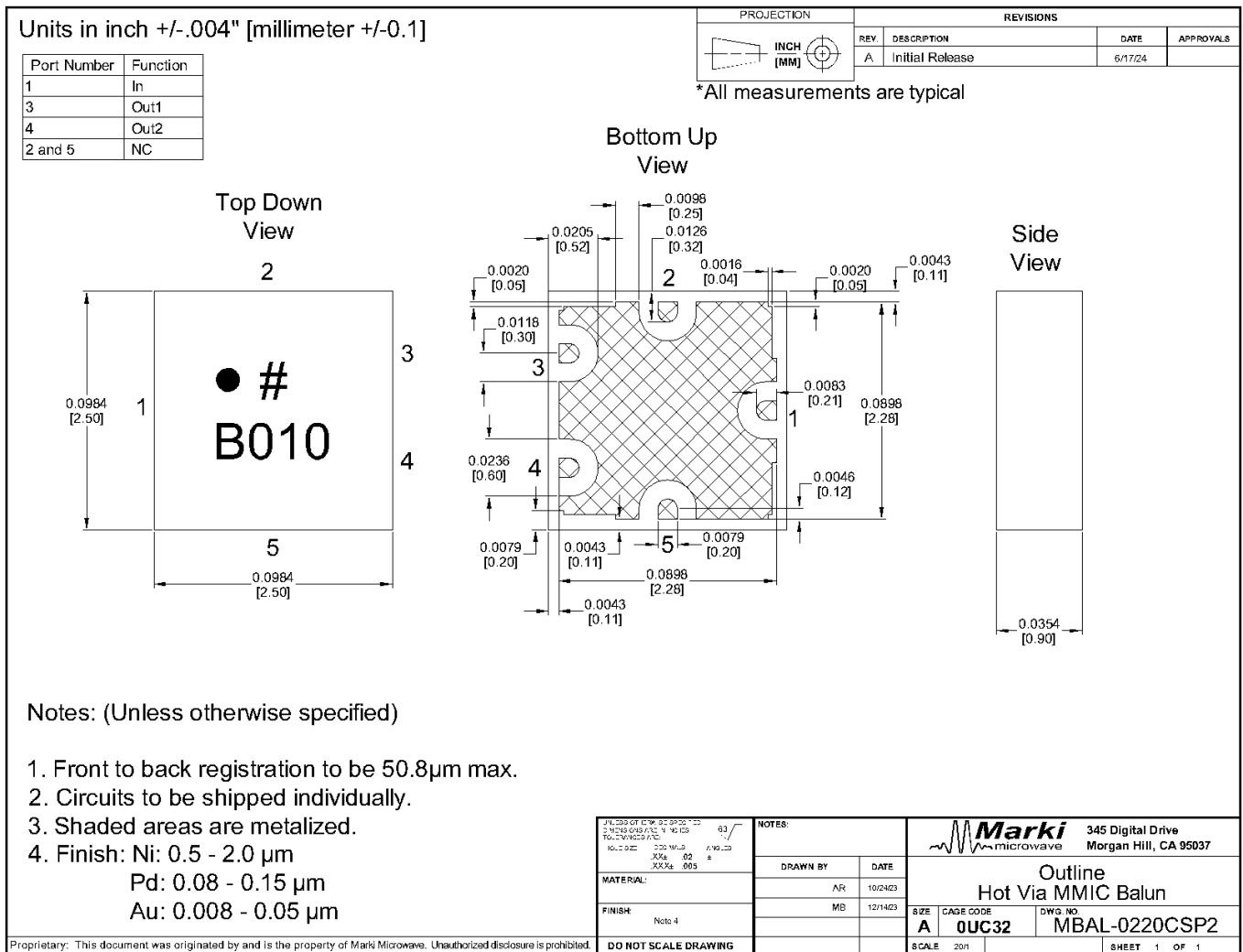

EVB Out- refers to output Out 1

EVB Out+ refers to output Out 2

MBAL-0220CSP2

2-20 GHz Passive MMIC Chip Scale Package

Balun

Footprint Image

Download: [Footprint Drawing](#)

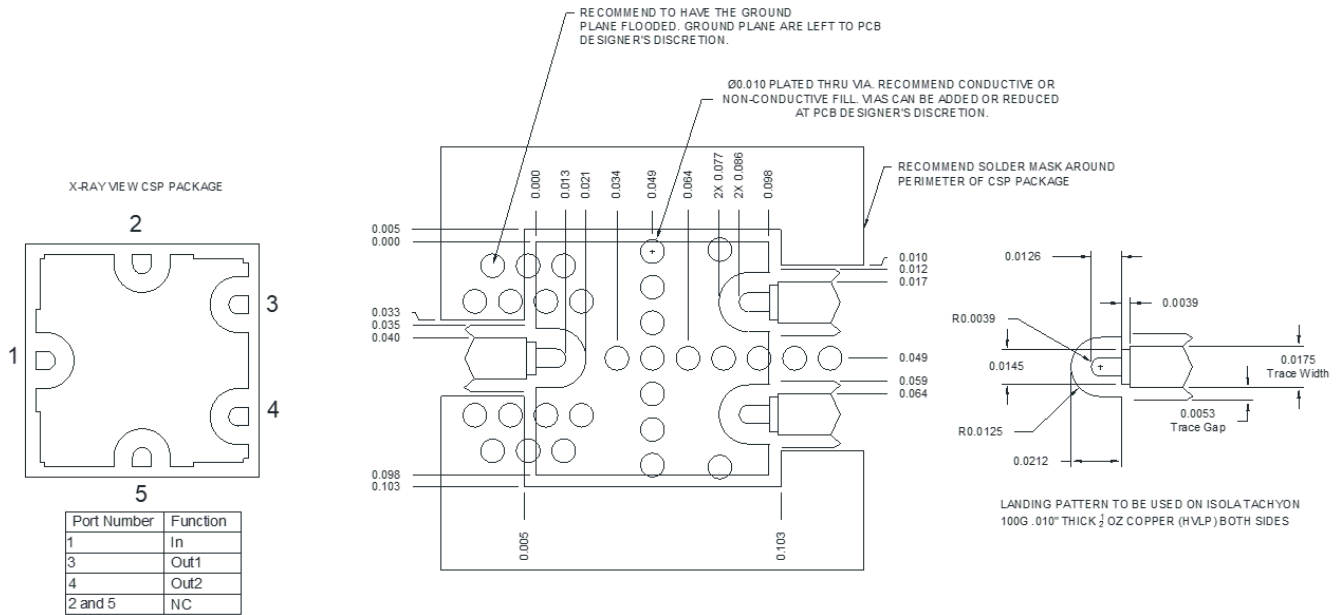

Evaluation Board - Performance Data

Parameter	Test Conditions	Frequency Range (GHz)	Min	Typ	Max	Unit
Impedance Ratio	-	-	-	2	-	

Evaluation Board - Outline Drawing

*All dimensions are typical

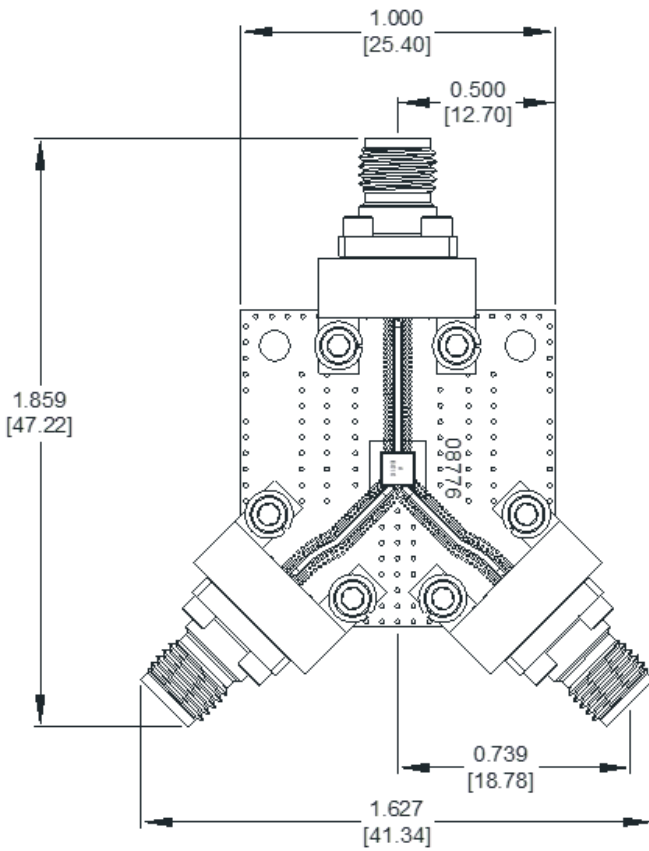

Bottom-up view:

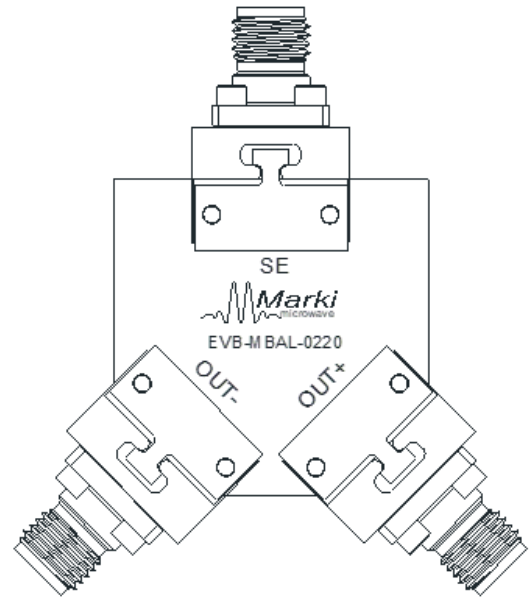

Port	Connector Type
1, 2, 3	2.92mm Female
Note: Connectors are not removeable.	

DISCLAIMER

MARKI MICROWAVE, LLC., ("MARKI") PROVIDES TECHNICAL SPECIFICATIONS AND DATA (INCLUDING DATASHEETS), APPLICATION OR OTHER DESIGN ADVICE, WEB TOOLS, AND OTHER INFORMATION AND RESOURCES "AS IS" AND WITH ALL FAULTS. MARKI DISCLAIMS ALL WARRANTIES, EXPRESS OR IMPLIED, INCLUDING, WITHOUT LIMITATION, ANY IMPLIED WARRANTIES OF MERCHANTABILITY, FITNESS FOR A PARTICULAR PURPOSE, OR NON-INFRINGEMENT.

These resources are intended for developers skilled in the art designing with Marki products. You are solely responsible for (1) selecting the appropriate products for your application, (2) designing, validating, and testing your application, and (3) ensuring your application meets applicable standards and other requirements. Marki makes no guarantee regarding the suitability of its products for any particular purpose, nor does Marki assume any liability whatsoever arising out of your use or application of any Marki product.

Marki grants you permission to use these resources only for development of an application that uses Marki products. Other reproduction or use of these resources is strictly prohibited. No license is granted to any other Marki intellectual property or to any third-party intellectual property. Marki reserves the right to make changes to the product(s) or information contained herein without notice.

MARKI MICROWAVE and T3 MIXER are trademarks or registered trademarks of Marki Microwave, LLC. All other trademarks used are the property of their respective owners.

© 2024 - 2025, Marki Microwave, LLC