

# AKA-1400PSM

## DC – 14 GHz Broadband InGaP SMT Amplifier

### DEVICE OVERVIEW

#### General Description

The AKA-1400PSM is a low-cost, cascadable broadband InGaP HBT amplifier. This is a general-purpose gain block amplifier which provides high P1dB, high OIP3, and a very small form factor. The simple application circuit requires minimal external components, allowing it to be used in a variety of applications.

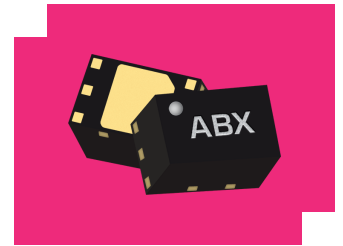

[Download s-parameters here](#)

#### Features

- Small Form Factor: 1.3 x 2.0mm
- +28dBm OIP3 up to 6 GHz
- 16dB Gain at 2 GHz
- Positive Only, Single Supply Operation
- Low-Cost

#### Applications

- Mobile test and measurement equipment
- Radar and satellite communications
- 5G transceivers
- Driver Amplifier L-Diode Mixers

#### Functional Block Diagram

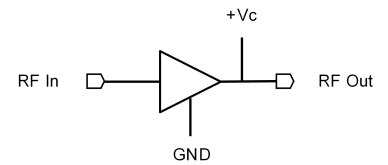

#### Part Ordering Options

Part Number	Description	Package	Green Status	Product Lifecycle	Export Classification
AKA-1400PSM	DC – 14 GHz Broadband InGaP SMT Amplifier	DFN	REACH RoHS	Released	EAR99
<u>EVB-AKA-1400P</u>	Evaluation Board, Broadband InGaP SMT DC – 14 GHz Amplifier	EVB	REACH RoHS	Released	EAR99

## AKA-1400PSM

### DC – 14 GHz Broadband InGaP SMT Amplifier

#### Table Of Contents

- **Device Overview**

- General Description
- Features
- Applications
- Functional Block Diagram

- **Port Configuration and Functions**

- Port Diagram
- Port Functions

- **Specifications**

- Absolute Maximum Ratings
- Package Information
- Recommended Operating Conditions
- Sequencing Requirements
- Electrical Specifications
- Typical Performance Plots

- **Operation**

- Application Circuit
- Application Circuit Description

- **Mechanical Data**

- Outline Drawing

- **Footprint Image**

- **Evaluation Board**

- Evaluation Board Outline Drawing



**Port Configuration and Functions**

**Port Diagram**

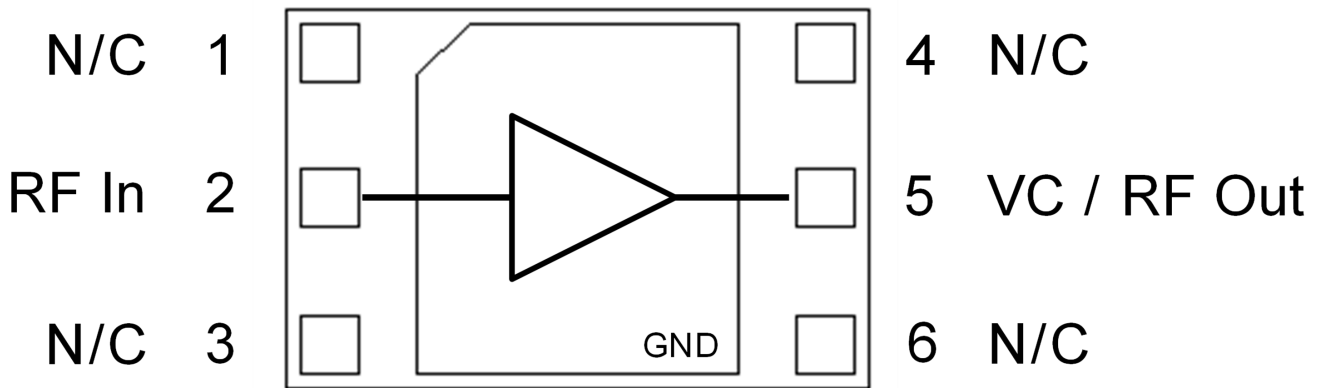
A port diagram of the AKA-1400PSM is shown below.

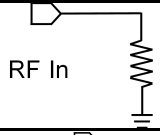
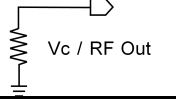

**Port Functions**

Port	Function	Description	Equivalent Circuit for Package
1, 3, 4, 6	N/C	These pins are internally no-connects and should be connected to DC/RF ground.	GND 
2	RF Input	This is the RF Input port of the amplifier die. It is RF matched to 50 Ω and requires an external DC blocking capacitor.	RF In 
5	RF Output and Positive Collector Voltage Supply	This is the RF Output and positive supply voltage port Vc. It is RF matched to 50 Ω and is DC coupled. An external bias tee is required on this port.	Vc / RF Out 
Paddle	Ground	Package ground paddle must be connected to a DC/RF ground potential with high thermal and electrical conductivity.	GND 

## Specifications

### Absolute Maximum Ratings

The Absolute Maximum Ratings indicate limits beyond which damage may occur to the device. If these limits are exceeded, the device may become inoperable or have a reduced lifetime.

Parameter	Maximum Rating	Unit
Maximum Operating Temperature	85	°C
Maximum Storage Temperature	150	°C
Max Junction Temperature for MTTF > 1E6 Hours	150	°C
Minimum Operating Temperature	-40	°C
Minimum Storage Temperature	65	°C
Positive Bias Current (Icc)	80	mA
Power Dissipation	312	mW
RF Input Power	10	dBm
$\theta_{JC}$ , Junction to Case Thermal Resistance	215	°C/W

### Package Information

Parameter	Details	Rating
ESD	250 to < 500 Volts	HBM Class 1A
Weight	Package name: DFN	0.007g
Dimensions	-	2.0 x 1.3 mm
Moisture Sensitivity Level	-	MSL 1

### Recommended Operating Conditions

The Recommended Operating Conditions indicate the limits, inside which the device should be operated, to guarantee the performance given in Electrical Specifications. Operating outside these limits may not necessarily cause damage to the device, but the performance may degrade outside the limits of the electrical specifications. For limits, above which damage may occur, see Absolute Maximum Ratings.

Parameter	Min	Nominal	Max	Unit
Positive DC Device Voltage (Vc)	3.7	3.8	3.9	V
Positive DC Current (Icc)	35	50	60	mA
Ambient Temperature	-40	25	85	°C

### Sequencing Requirements

There is no sequencing required to power up or power down the amplifier.

## Electrical Specifications

Unless otherwise specified, electrical specifications apply at TA=+25°C, Vc = +3.8V in a 50Ω system. Typical performance data is measured from EVB unless otherwise stated. Min and Max limits are guaranteed at TA=+25°C.

Parameter	Test Conditions	Minimum Frequency (GHz)	Maximum Frequency (GHz)	Min	Typ	Max	Unit
DC Supply Quiescent Current (Icc)	Vc = +3.8V, No RF Input	-	-	-	50	-	mA
Input Return Loss	Vc = +3.8 V, Icc = 50 mA	0.1	14	-	10	-	dB
Noise Figure	Vc = +3.8 V, Icc = 50 mA	6	14	-	5	-	dB
Noise Figure	Vc = +3.8 V, Icc = 50 mA	0.1	6	-	4	-	dB
Output IP3	Vc = +3.8 V, Icc = 50 mA	6	14	-	25	-	dBm
Output IP3	Vc = +3.8 V, Icc = 50 mA	0.1	6	-	28	-	dBm
Output P1dB	Vc = +3.8 V, Icc = 50 mA	2	6	10	15	-	dBm
Output P1dB	Vc = +3.8 V, Icc = 50 mA	6	14	8	13	-	dBm
Output Return Loss	Vc = +3.8 V, Icc = 50 mA	0.1	14	-	15	-	dB
Reverse Isolation	Vc = +3.8 V, Icc = 50 mA	0.1	14	-	18	-	dB
Small Signal Gain	Vc = +3.8 V, Icc = 50 mA	0.1	1	16	17	-	dB
Small Signal Gain	Vc = +3.8 V, Icc = 50 mA	12	14	8	10	-	dB
Small Signal Gain	Vc = +3.8 V, Icc = 50 mA	6	12	10	12	-	dB
Small Signal Gain	Vc = +3.8 V, Icc = 50 mA	4	6	14	15	-	dB
Small Signal Gain	Vc = +3.8 V, Icc = 50 mA	1	4	15	16	-	dB

### Typical Performance Plots

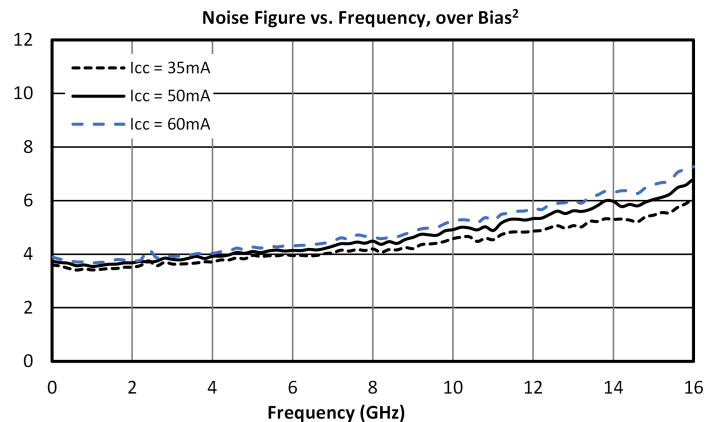
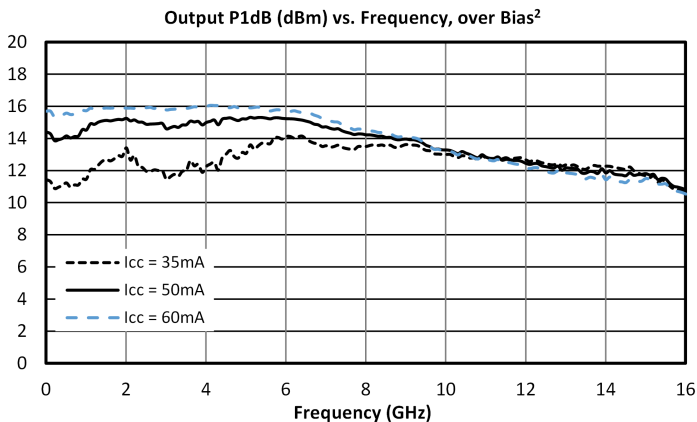
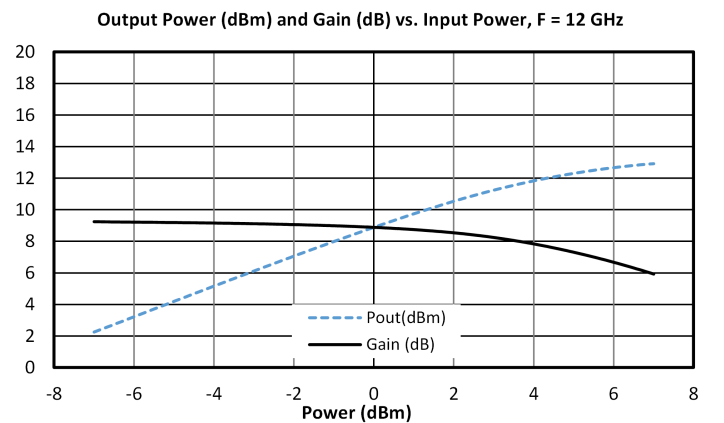
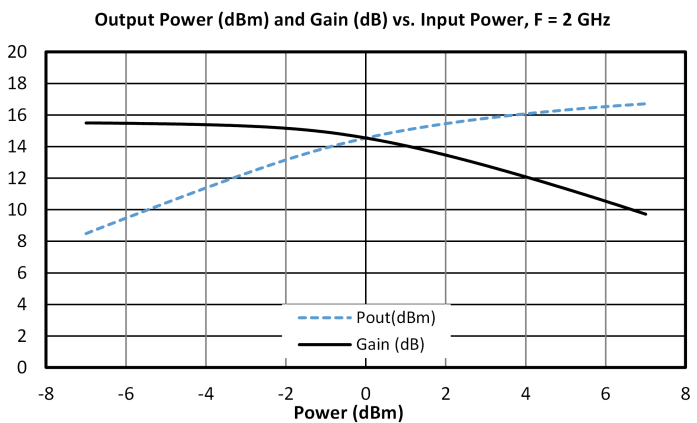
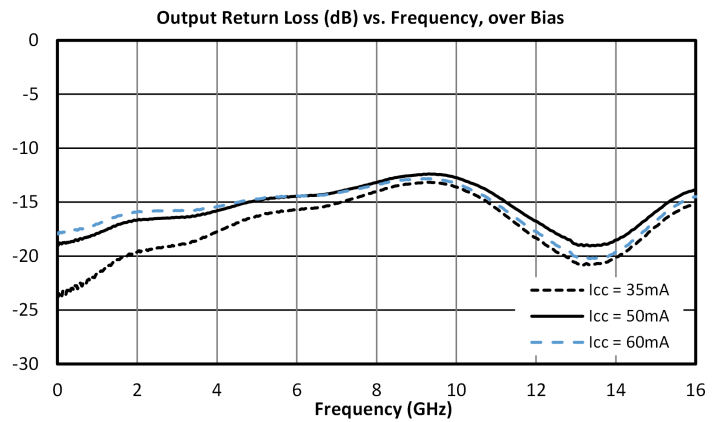
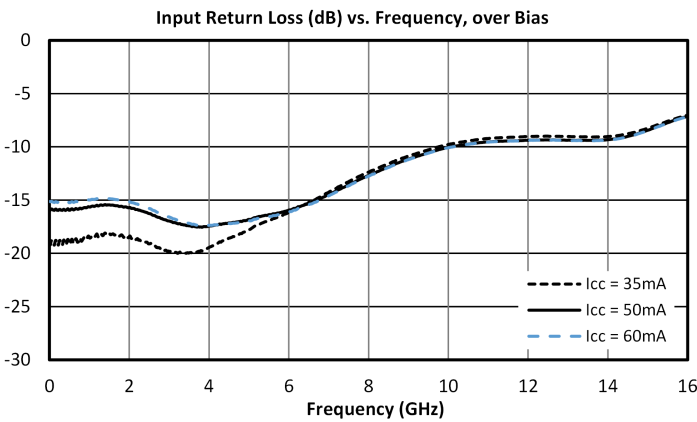
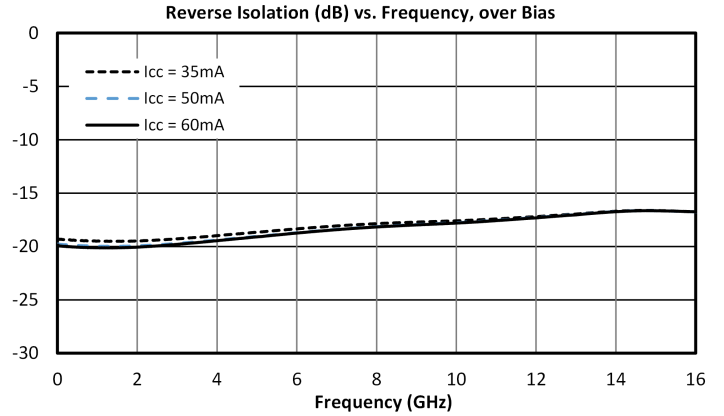
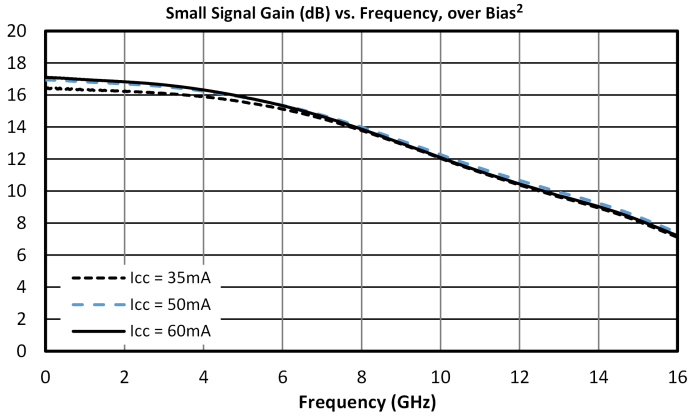

# AKA-1400PSM

## DC – 14 GHz Broadband InGaP SMT Amplifier

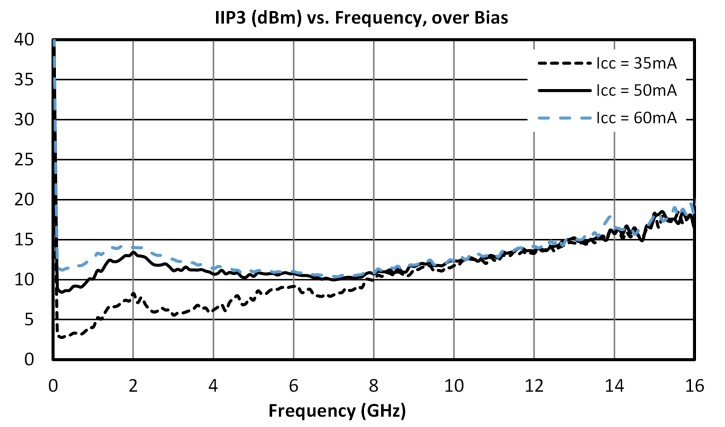
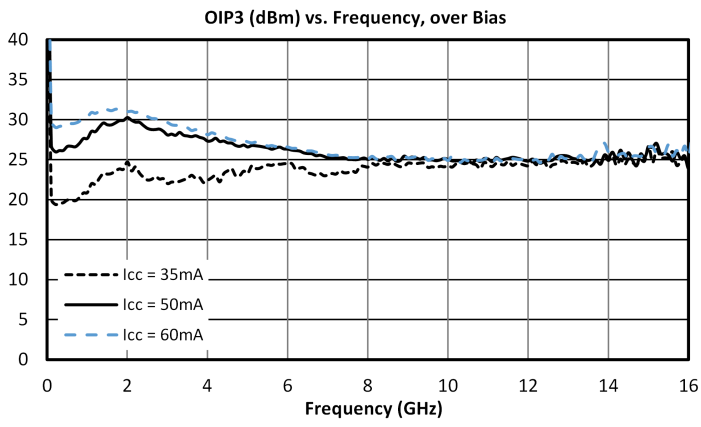

**Application Circuit**

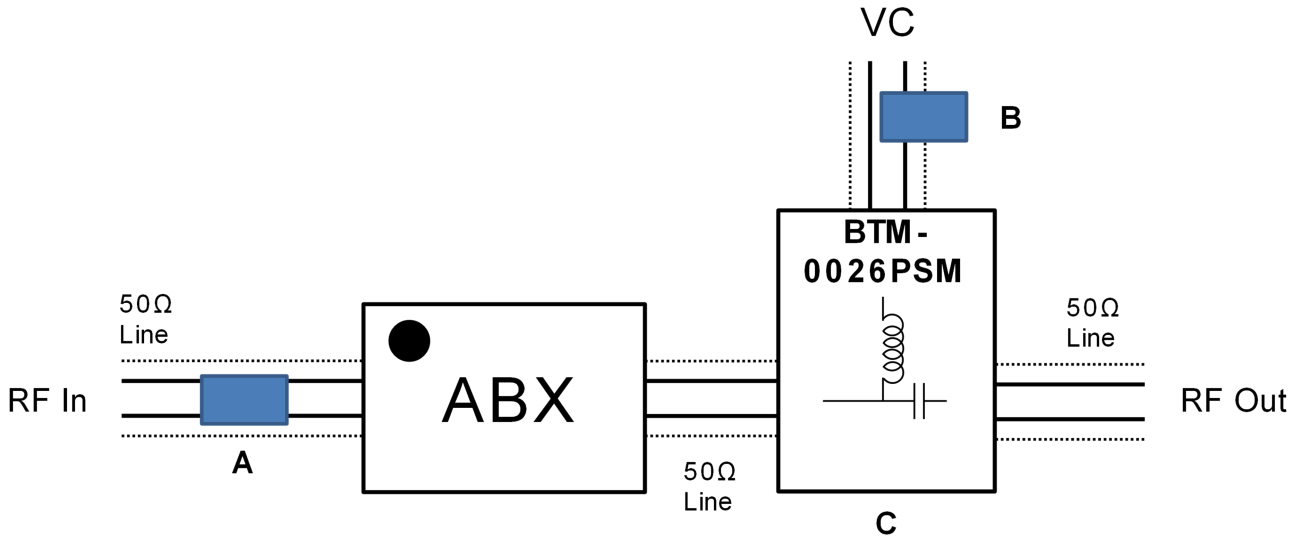

**Application Circuit Description**

The RF input and output should be soldered to 50Ω traces. This amplifier requires external DC blocking on the input and output in addition to positive collector biasing on the output. The BTM-0026PSM is recommended to bias and DC the amplifier for its small 2.25 x 3.7mm footprint and excellent insertion loss performance.

Designator	Description	Sample Part Number
A	0201 0.1 μF SMT Capacitor	---
B	0201 0.1 μF SMT Capacitor	---
C	Marki Surface-Mount Mini Bias Tee; 10 MHz – 26 GHz	BTM-0026PSM

### Mechanical Data

### Outline Drawing

Download : [Outline 3D Drawing](#) | [Outline 3D STP](#)

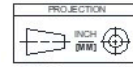

All dimensions are typical

Pad #	Function
1	N/C
2	RF In
3	N/C
4	N/C
5	RF Out/VC
6	N/C

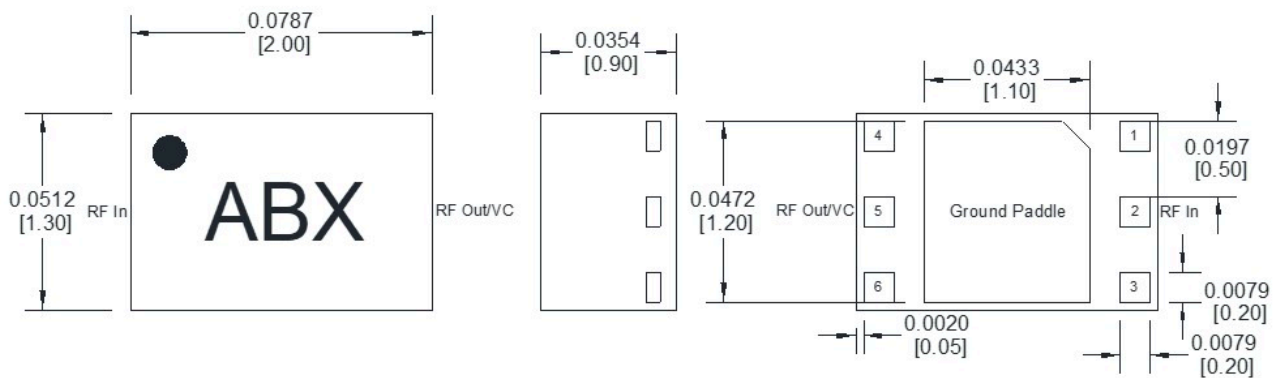

Notes (unless otherwise specified):

- Substrate material is LCP.
- I/O Leads and Die Paddle are (from base to finish):
  - Ni: 0.5 microns MIN
  - Pd: 0.02 microns MIN
  - Au: 0.05 microns MAX
- All unconnected pins should be connected to PCB RF ground.

## AKA-1400PSM

DC – 14 GHz Broadband InGaP SMT Amplifier

### Footprint Image

Download : [Footprint Drawing](#)

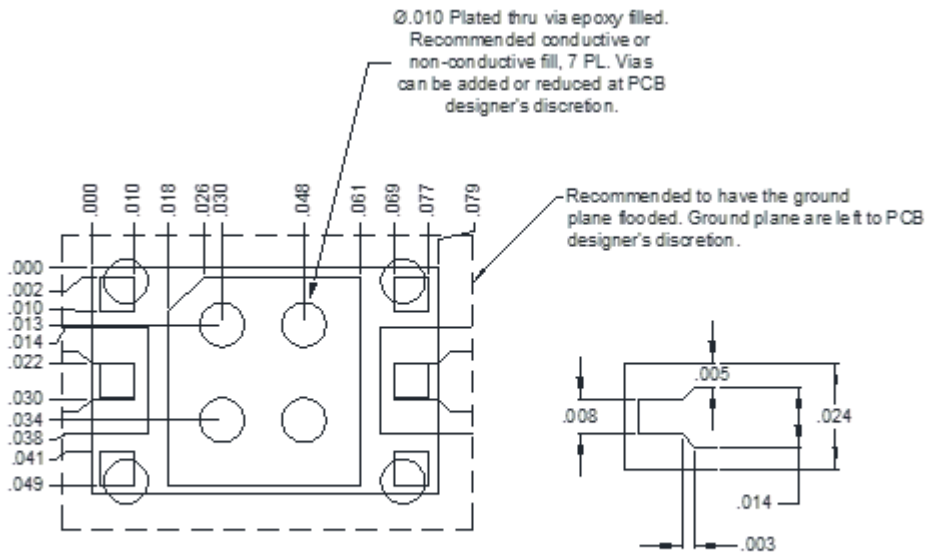

**Evaluation Board - Outline Drawing**

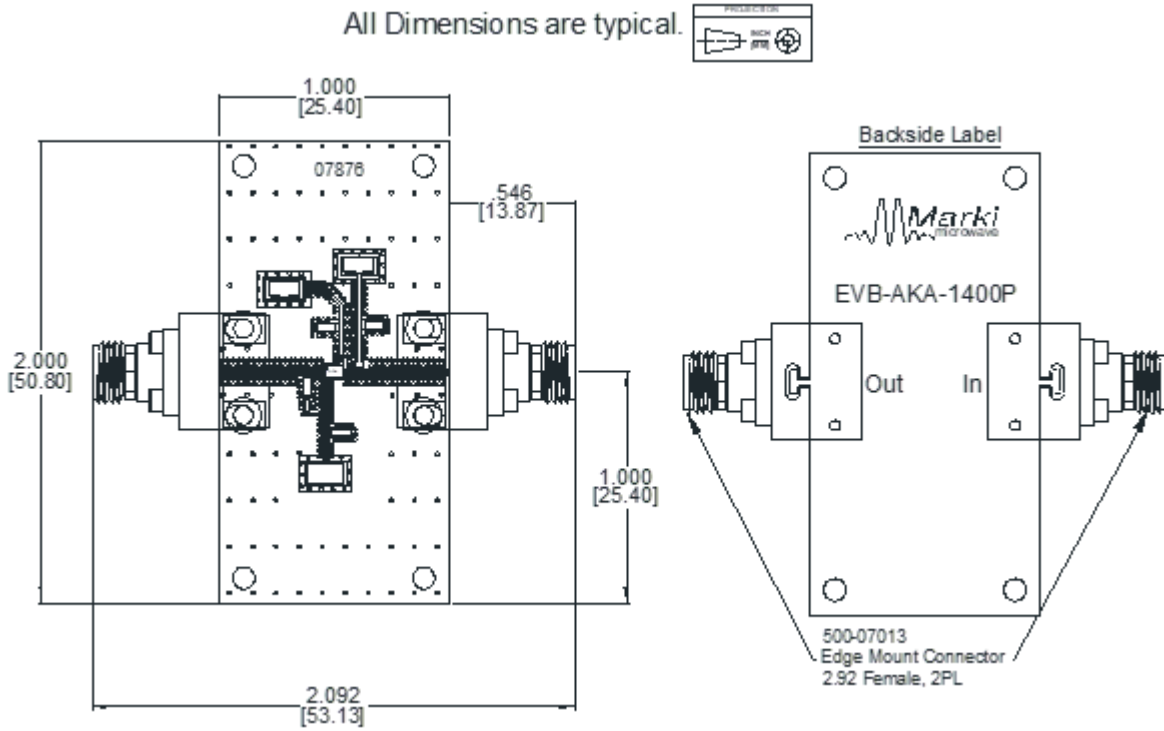

**DISCLAIMER**

MARKI MICROWAVE, INC., (“MARKI”) PROVIDES TECHNICAL SPECIFICATIONS AND DATA (INCLUDING DATASHEETS), APPLICATION OR OTHER DESIGN ADVICE, WEB TOOLS, AND OTHER INFORMATION AND RESOURCES “AS IS” AND WITH ALL FAULTS. MARKI DISCLAIMS ALL WARRANTIES, EXPRESS OR IMPLIED, INCLUDING, WITHOUT LIMITATION, ANY IMPLIED WARRANTIES OF MERCHANTABILITY, FITNESS FOR A PARTICULAR PURPOSE, OR NON-INFRINGEMENT. These resources are intended for developers skilled in the art designing with Marki products. You are solely responsible for (1) selecting the appropriate products for your application, (2) designing, validating, and testing your application, and (3) ensuring your application meets applicable standards and other requirements. Marki makes no guarantee regarding the suitability of its products for any particular purpose, nor does Marki assume any liability whatsoever arising out of your use or application of any Marki product.

Marki grants you permission to use these resources only for development of an application that uses Marki products. Other reproduction or use of these resources is strictly prohibited. No license is granted to any other Marki intellectual property or to any third-party intellectual property. Marki reserves the right to make changes to the product(s) or information contained herein without notice.

MARKI MICROWAVE and T3 MIXER are trademarks or registered trademarks of Marki Microwave, Inc. All other trademarks used are the property of their respective owners.

© 2022 - 2025, Marki Microwave, Inc