

# MT3H-0113HSM-2

## GaAs MMIC High Dynamic Range Mixer

### DEVICE OVERVIEW

#### General Description

The MT3H-0113HSM is a triple balanced passive diode mixer offering high dynamic range, low conversion loss, and excellent repeatability. As with all T3 mixers, this mixer offers unparalleled nonlinear performance in terms of IIP3, P1dB, and spurious performance with a flexible LO drive requirement from +16 dBm to +24 dBm. RF, LO, and IF ports are all operated single ended due to integrated baluns. The MT3H-0113HSM is available in a 4x4mm QFN, or in an SMA connectorized evaluation fixture. The MT3H-0113HSM is a superior alternative to Marki Microwave carrier and packaged T3 mixers.

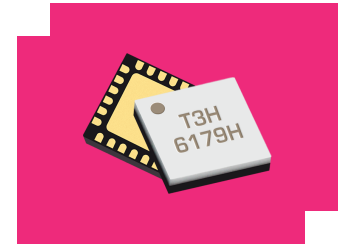

#### Features

- Industry-Leading Spurious, IP3, and P1dB Performance
- RoHS Compliant
- Broadband, Overlapping RF, LO, and IF

#### Applications

N/A

#### Functional Block Diagram

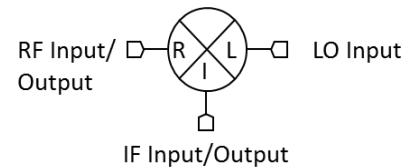

#### Part Ordering Options

Part Number	Description	Package	Packing Size	Green Status	Product Lifecycle	Export Classification
MT3H-0113HSM-2	GaAs MMIC High Dynamic Range Mixer	QFN	-	REACH RoHS	Released	EAR99
EVAL-MT3H-0113H	Evaluation Board, GaAs MMIC High Dynamic Range Mixer	EVAL	-	REACH RoHS	Released	EAR99
MT3H-0113H-2-TR	Tape and Reel, GaAs MMIC High Dynamic Range Mixer	QFN	7"	REACH RoHS	Released	EAR99

## Table Of Contents

- **Device Overview**
  - General Description
  - Features
  - Applications
  - Functional Block Diagram
- **Port Configuration and Functions**
  - Port Diagram
  - Port Functions
- **Revision History**
- **Specifications**
  - Absolute Maximum Ratings
  - Package Information
  - Recommended Operating Conditions
  - Electrical Specifications
  - Typical Performance
  - Spur Tables
- **Mechanical Data**
  - Outline Drawing
- **Footprint Image**
- **Evaluation Board**
- **Notes**

## Revision History

Revision Code	Revision Date	Comment
-	2017-01-01	Initial Release
A	2019-01-01	Revised square wave LO IP3 plots. End note 5 updated to reflect new test condition.

## Port Configuration and Functions

### Port Diagram

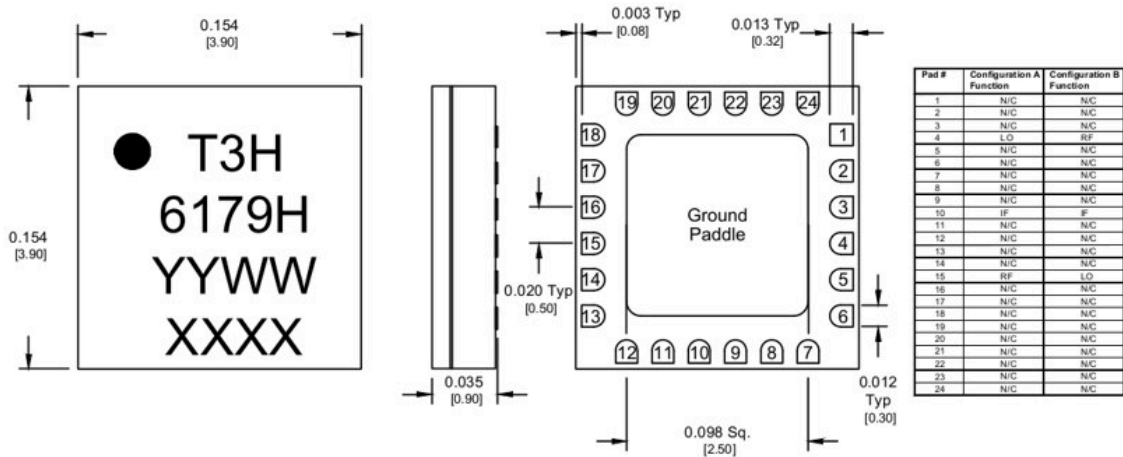

1. Substrate material is Ceramic.
2. All unconnected pads should be connected to PCB RF ground.
3. ENEPIG Plating/Finish: Ni: 8.89 micron|max, 1.27 micron min. Pd: 0.17 micron max, 0.07 micron min. Au: 0.254 micron max, 0.03 micron min.

## Port Functions

### Configuration A

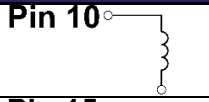
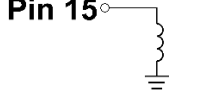
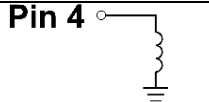
Port	Function	Description	Equivalent Circuit for Package
Pin 10	IF	Pin 10 is DC open. Blocking capacitor is optional.	
Pin 15	RF	Pin 15 is DC short and AC matched to 50 Ω from 0.8 to 13 GHz. Blocking capacitor is optional.	
Pin 4	LO	Pin 4 is DC short and AC matched to 50 Ω from 0.8 to 13 GHz. Blocking capacitor is optional.	

**Configuration B**

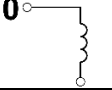
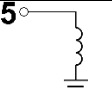
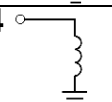
Port	Function	Description	Equivalent Circuit for Package
Pin 10	IF	Pin 10 is DC open. Blocking capacitor is optional.	<b>Pin 10</b> 
Pin 15	LO	Pin 15 is DC short and AC matched to 50 Ω from 0.8 to 13 GHz. Blocking capacitor is optional.	<b>Pin 15</b> 
Pin 4	RF	Pin 4 is DC short and AC matched to 50 Ω from 0.8 to 13 GHz. Blocking capacitor is optional.	<b>Pin 4</b> 

## Specifications

### Absolute Maximum Ratings

Parameter	Maximum Rating	Unit
Maximum Operating Temperature	100	°C
Maximum Storage Temperature	125	°C
Minimum Operating Temperature	-55	°C
Minimum Storage Temperature	-65	°C
RF Power Handling (RF+LO)	30	dBm

### Package Information

Parameter	Details	Rating
Dimensions	-	4 x 4 mm
Moisture Sensitivity Level	-	MSL 1

### Recommended Operating Conditions

Parameter	Min	Nominal	Max	Unit
LO Input Power	16	-	24	-

### Electrical Specifications

Specifications guaranteed from -55 to +100°C, measured in a 50Ω system. All bare die are 100% DC tested and 100% visually inspected. RF testing is performed on a sample basis to verify conformance to datasheet guaranteed specifications. Consult factory for more information.

Parameter	Port Configuration	Test Conditions	Min	Typ	Max	Unit
Conversion Loss <sup>1</sup>	A	LO/RF=1.5-13 GHz IF=0.8-1 GHz LO Drive Level=20dBm	-	8	12	dB
IF Frequency Range	A	-	0.8	-	8.5	GHz
Input IP3 <sup>2</sup>	A	LO/RF=1.5-13 GHz IF=0.8-8.5 GHz LO Drive Level=16-24dBm	-	29	-	dBm
LO Frequency Range	A	-	1.5	-	13	GHz
RF Frequency Range	A	-	1.5	-	13	GHz
Conversion Loss <sup>3</sup>	B	LO/RF=1.5-13 GHz IF=1-8.5 GHz LO Drive Level=20dBm	-	11.5	-	dB
Input IP3 <sup>4</sup>	B	LO/RF=1.5-13 GHz IF=0.8-8.5 GHz LO Drive Level=16-24dBm	-	30	-	dBm
Isolation, LO to RF	-	-	-	37	-	dB

[1][3] Measured Conversion Loss measured at 1 GHz fixed IF.

[2][4] IP3 depends on LO drive conditions, see plots for more details.

**Typical Performance**

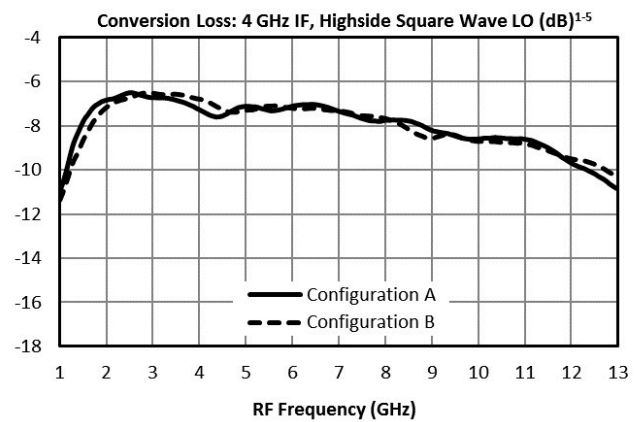
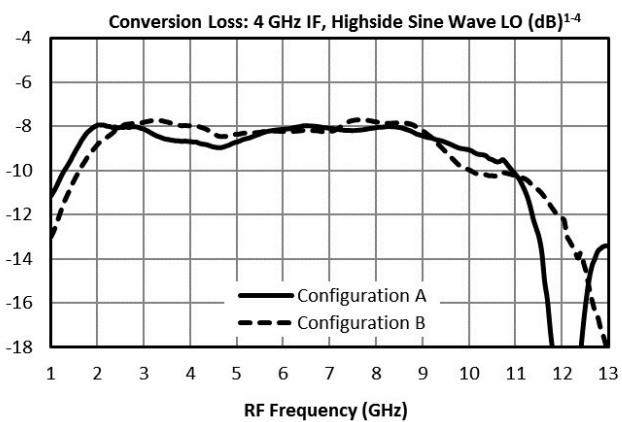
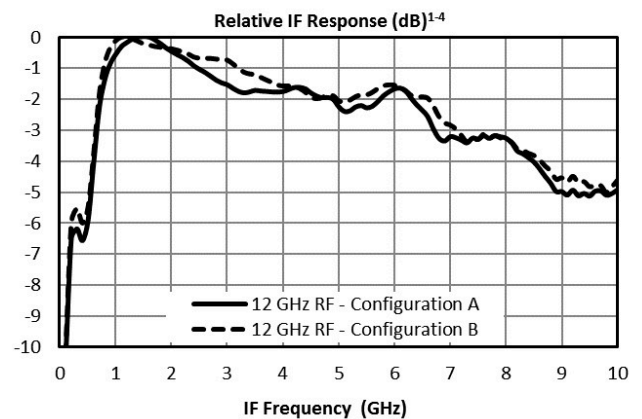
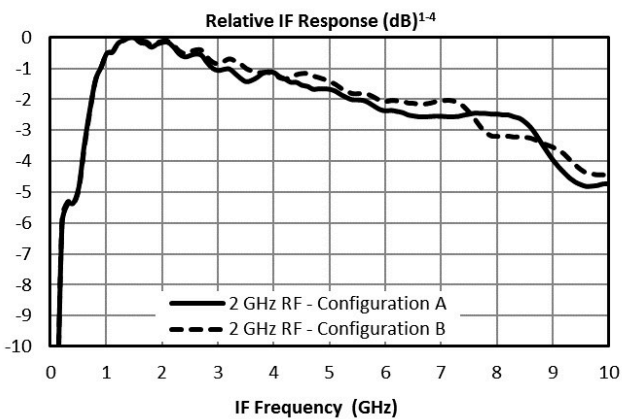
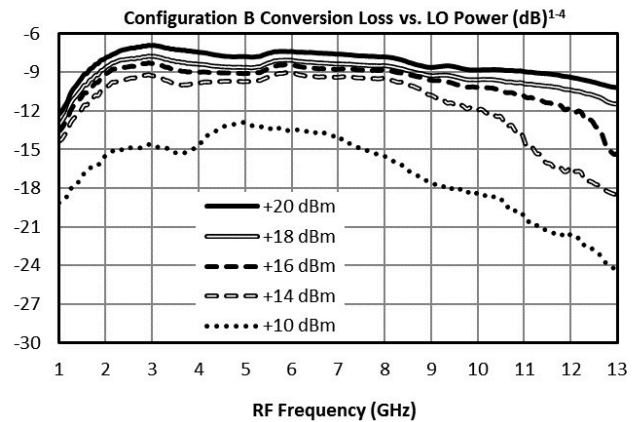
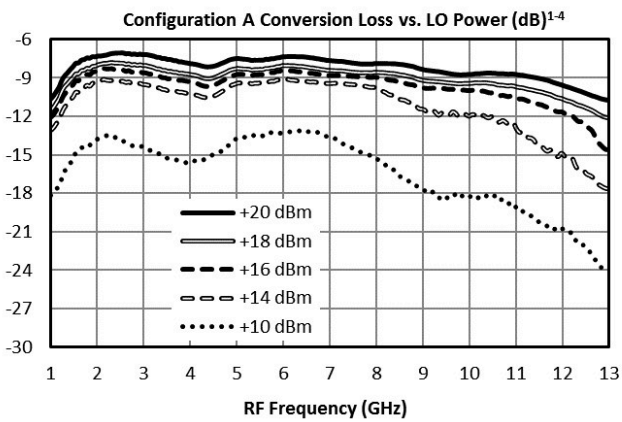
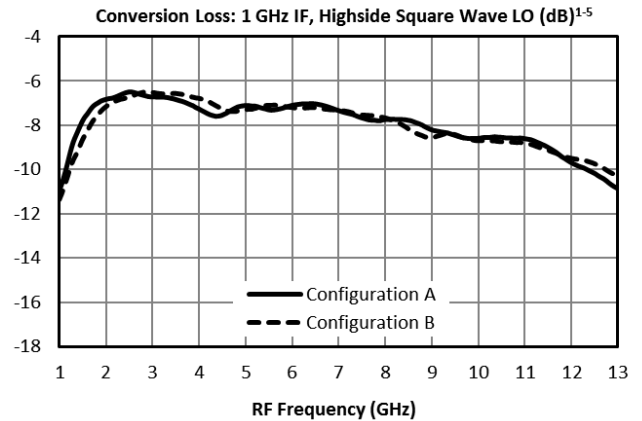
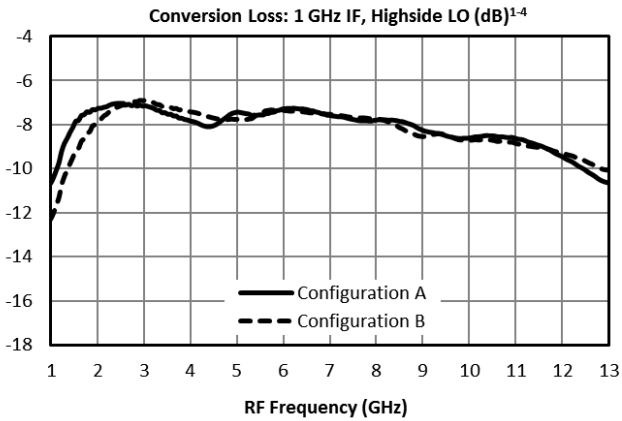

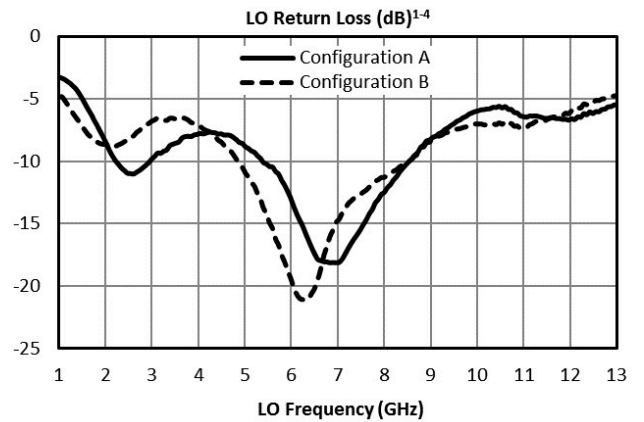
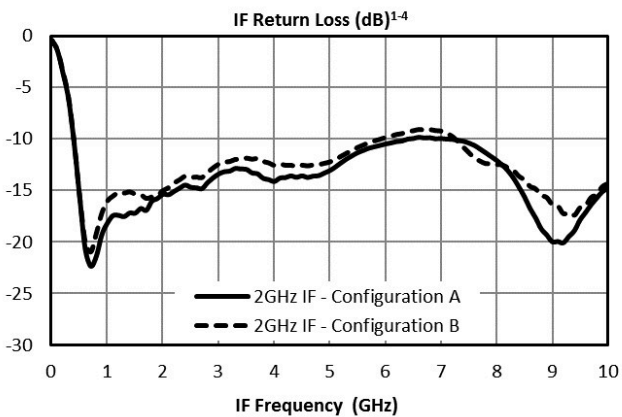
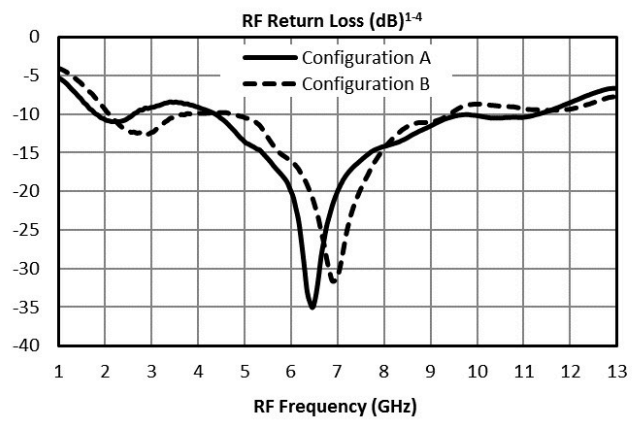
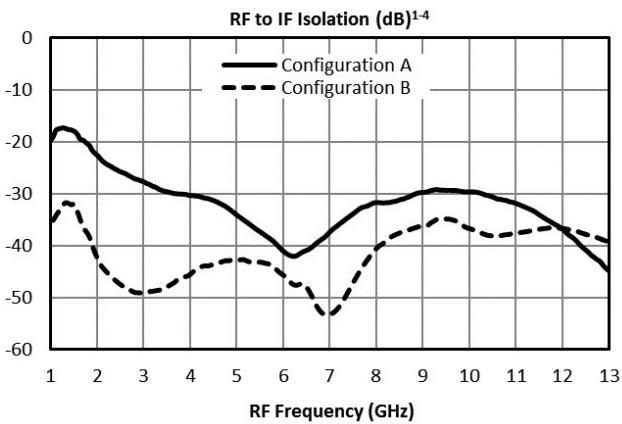
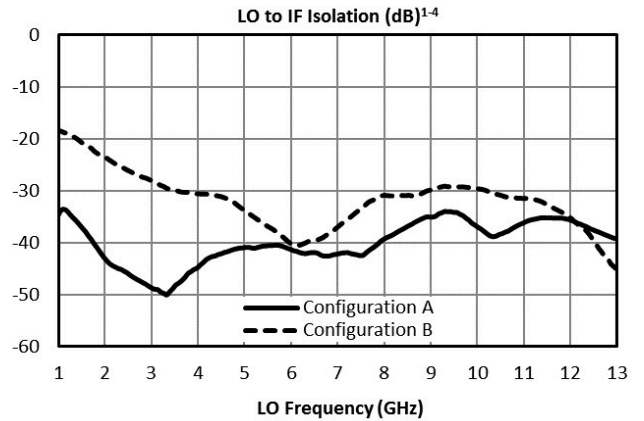
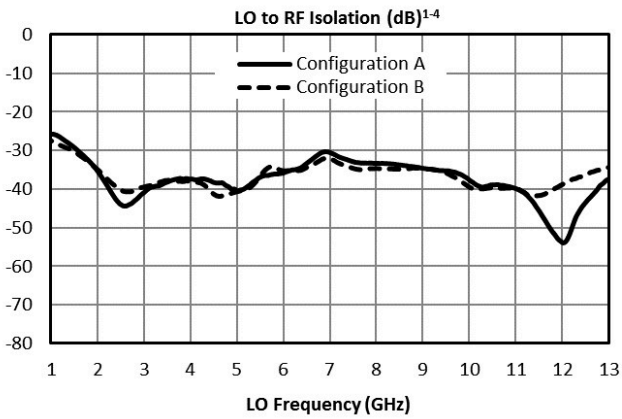
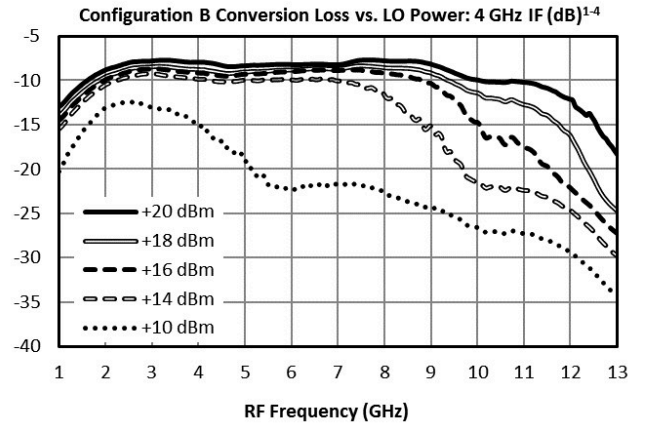
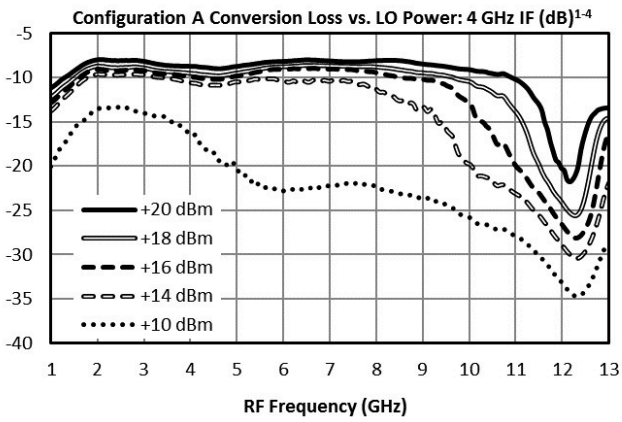

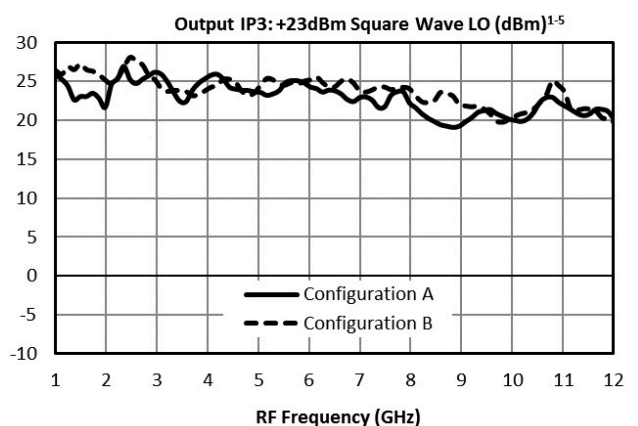
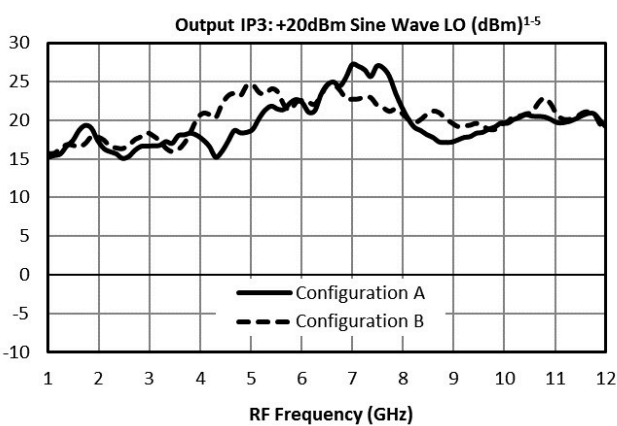
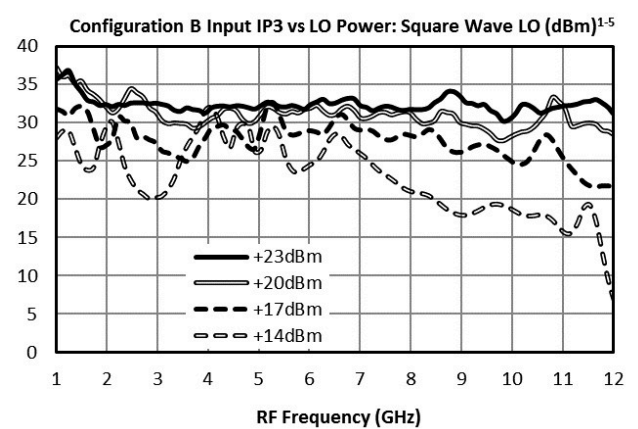
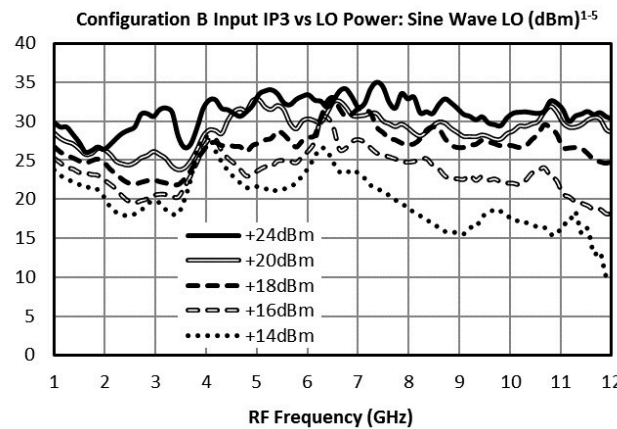
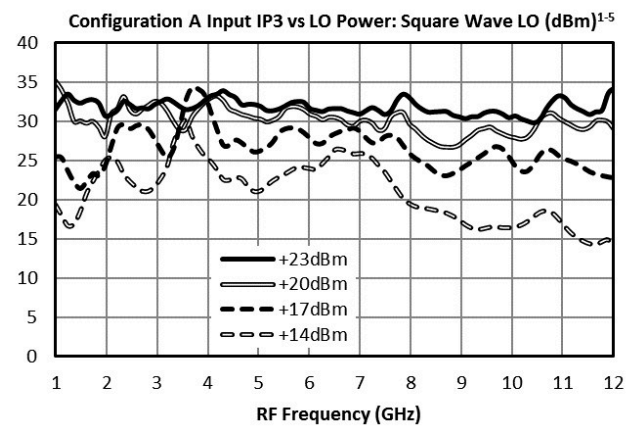
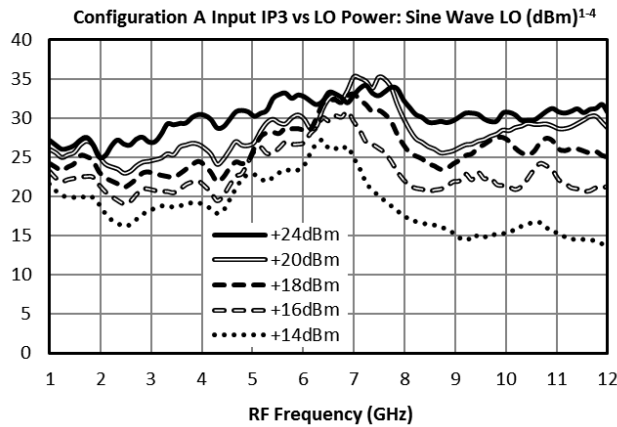
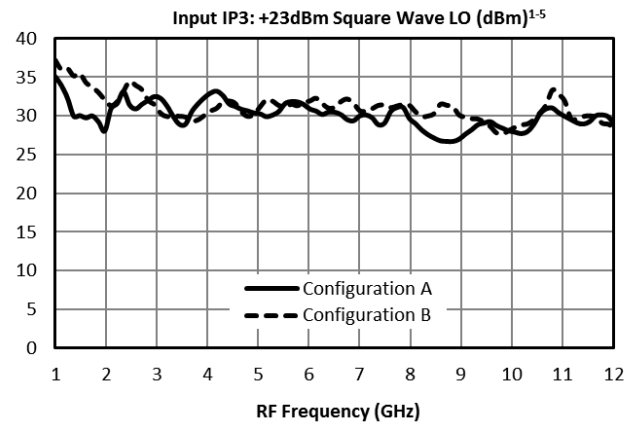
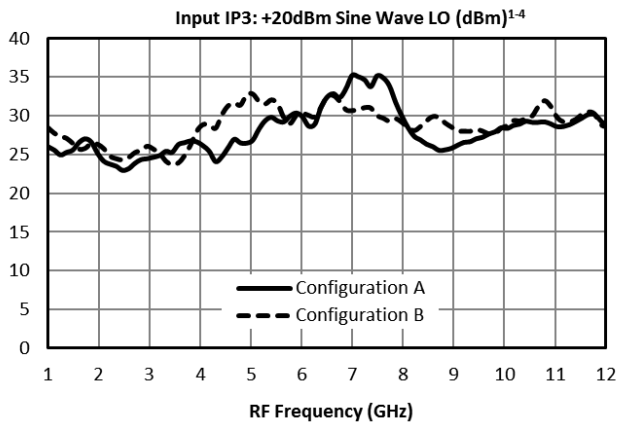

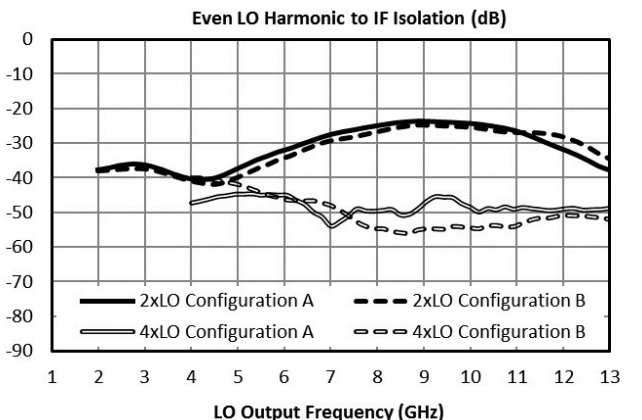
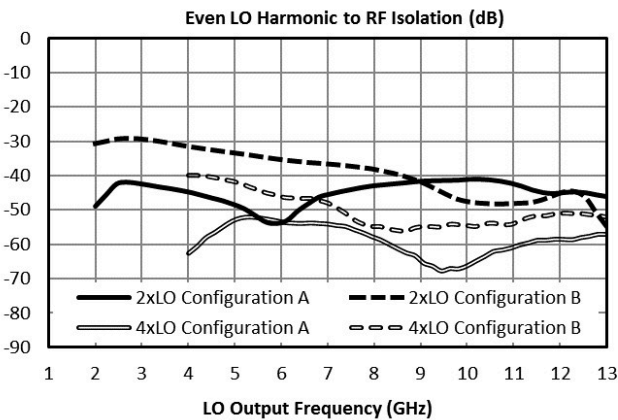
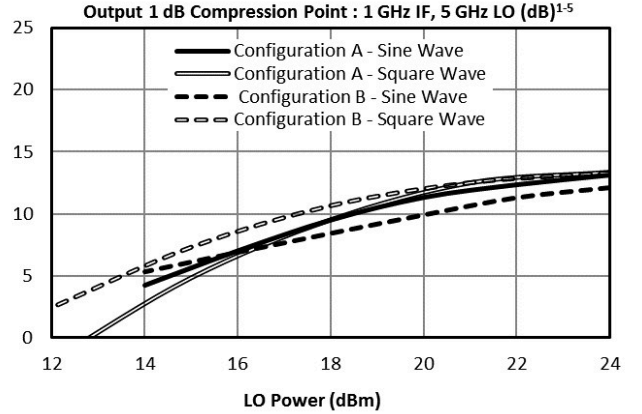
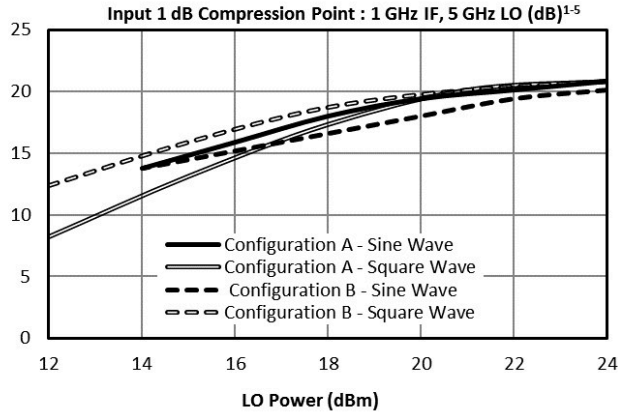
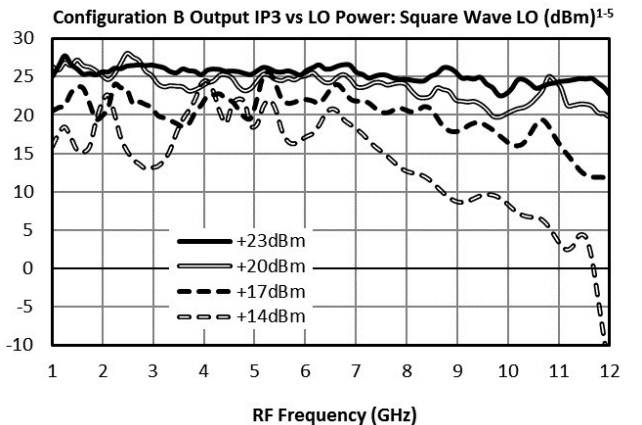
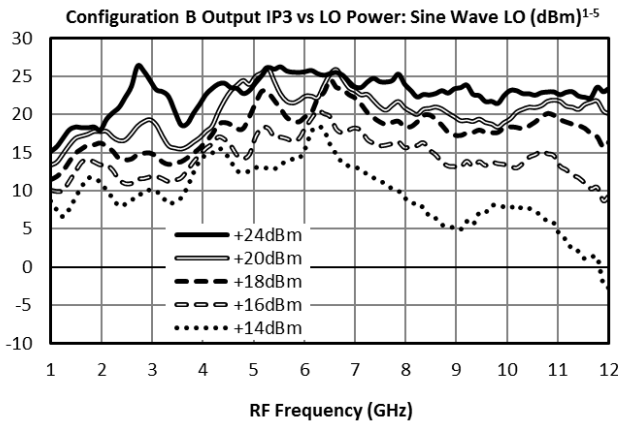
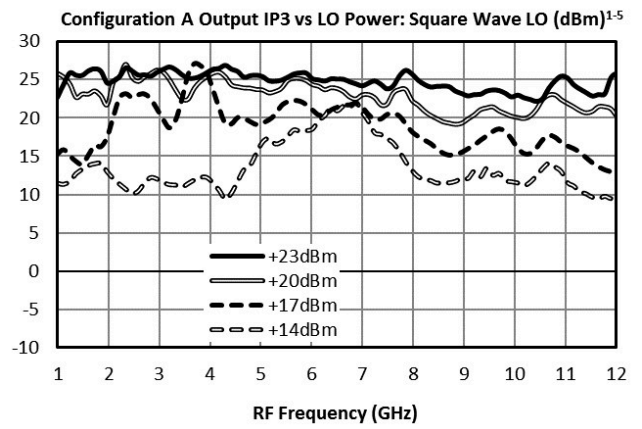
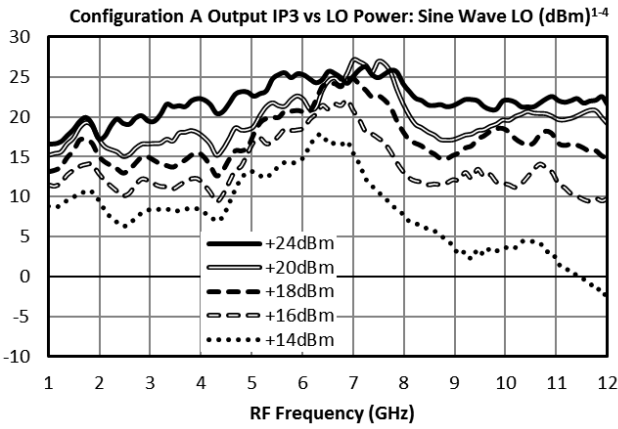

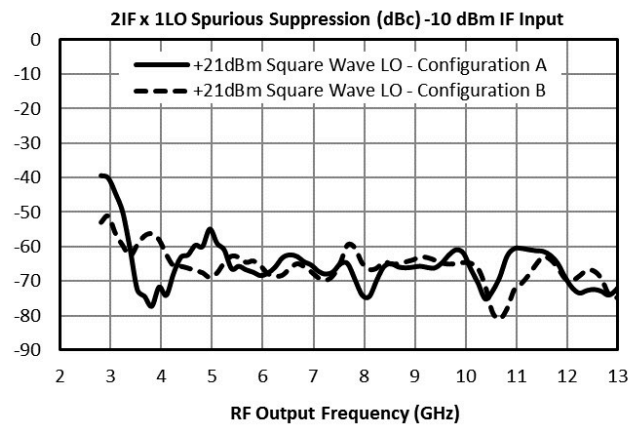
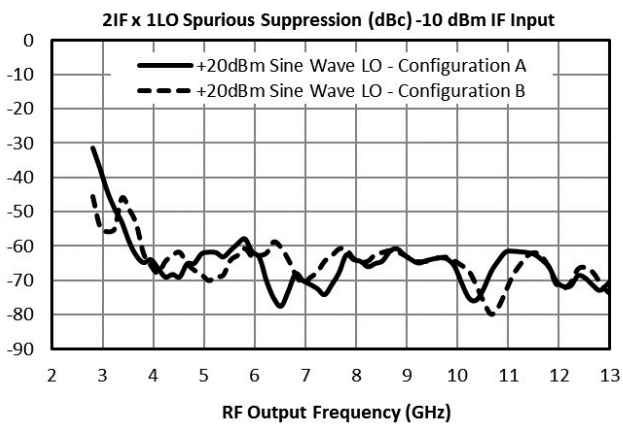
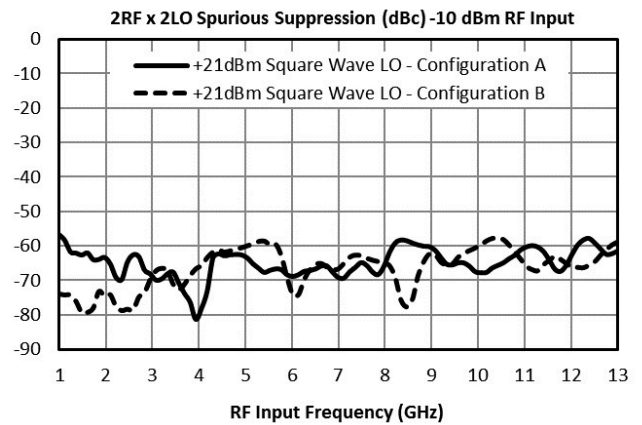
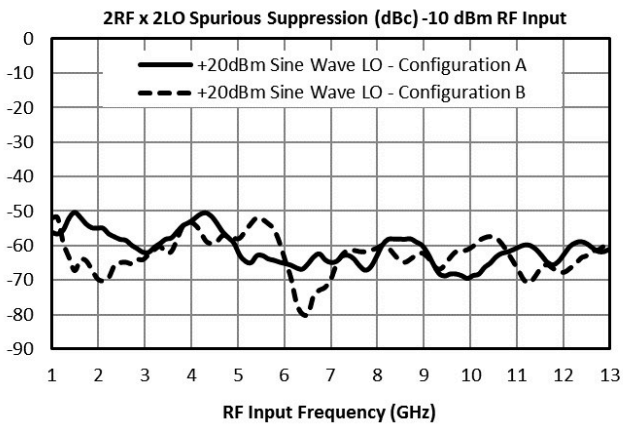
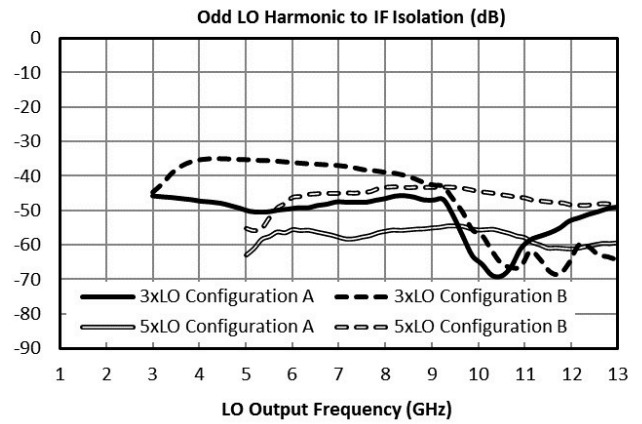
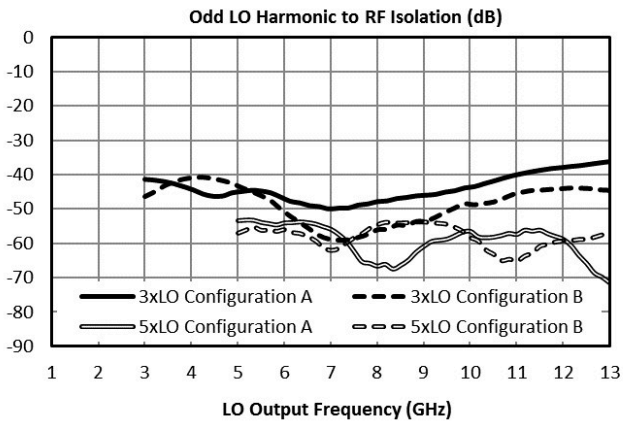

## Spur Table

### Downconversion Spurious Suppression

Spurious data is taken by selecting RF and LO frequencies (+mLO+nRF) within the RF/LO bands, to create a spurious output within the IF band. The mixer is swept across the full spurious band and the mean is calculated. The numbers shown in the table below are for a -10 dBm RF input. Spurious suppression is scaled for different RF power levels by (n-1), where “n” is the RF spur order. For example, the 2RFx2LO spur is 61 dBc for the A configuration for a -10 dBm input, so a -20 dBm RF input creates a spur that is (2-1) x (-10 dB) dB lower, or 71 dBc.

**Typical Downconversion Spurious Suppression (dBc): A Configuration (B Configuration), Sine Wave LO <sup>6</sup>**

-10 dBm RF Input	0xLO	1xLO	2xLO	3xLO	4xLO	5xLO
1xRF	27 (31)	Reference	30 (36)	21 (19)	22 (33)	20 (24)
2xRF	60 (59)	66 (62)	61 (63)	63 (59)	61 (64)	66 (58)
3xRF	105 (97)	83 (86)	91 (93)	77 (78)	94 (93)	118 (120)
4xRF	126 (128)	125 (126)	123 (123)	122 (121)	119 (121)	121 (124)
5xRF	152 (157)	149 (154)	148 (149)	144 (144)	147 (149)	140 (141)

**Typical Downconversion Spurious Suppression (dBc): A Configuration (B Configuration), Square Wave LO <sup>6</sup>**

-10 dBm RF Input	0xLO	1xLO	2xLO	3xLO	4xLO	5xLO
1xRF	27 (32)	Reference	29 (36)	15 (13)	24 (39)	19 (20)
2xRF	62 (58)	67 (63)	65 (67)	66 (62)	64 (67)	68 (64)
3xRF	104 (103)	97 (99)	103 (108)	91 (94)	100 (107)	129 (128)
4xRF	126 (127)	131 (134)	128 (134)	130 (131)	128 (134)	126 (129)
5xRF	163 (162)	164 (169)	164 (168)	163 (163)	166 (170)	160 (165)

## Upconversion Spurious Suppression

Spurious data is taken by mixing an input within the IF band, with LO frequencies (+mLO+nIF), to create a spurious output within the RF output band. The mixer is swept across the full spurious output band and the mean is calculated. The numbers shown in the table below are for a -10 dBm IF input. Spurious suppression is scaled for different IF input power levels by (n-1), where “n” is the IF spur order. For example, the 2IFx1LO spur is typically 65 dBc for the A configuration for a -10 dBm input, so a -20 dBm IF input creates a spur that is (2-1) x (-10 dB) dB lower, or 75 dBc.

**Typical Upconversion Spurious Suppression (dBc): A Configuration (B Configuration), Sine Wave LO <sup>6</sup>**

-10 dBm RF Input	0xLO	1xLO	2xLO	3xLO	4xLO	5xLO
1xIF	22 (27)	Reference	29 (34)	19 (18)	26 (38)	21 (22)
2xIF	69 (61)	65 (65)	62 (56)	61 (63)	56 (49)	56 (58)
3xIF	92 (78)	98 (98)	98 (99)	85 (87)	87 (95)	79 (84)
4xIF	119 (116)	128 (129)	122 (124)	120 (124)	120 (120)	113 (119)
5xIF	149 (140)	158 (163)	162 (161)	152 (153)	155 (154)	146 (144)

**Typical Upconversion Spurious Suppression (dBc): A Configuration (B Configuration), Square Wave LO <sup>6</sup>**

-10 dBm RF Input	0xLO	1xLO	2xLO	3xLO	4xLO	5xLO
1xIF	22 (27)	Reference	31 (37)	15 (13)	24 (39)	19 (20)
2xIF	69 (61)	65 (65)	61 (57)	66 (62)	64 (67)	68 (64)
3xIF	92 (78)	97 (99)	98 (106)	91 (94)	100 (107)	129 (128)
4xIF	119 (116)	128 (129)	124 (128)	130 (131)	128 (134)	126 (129)
5xIF	149 (140)	158 (163)	163 (166)	163 (163)	166 (170)	160 (165)

**Mechanical Data**

**Outline Drawing**

Download : [Outline 2D Drawing](#) | [Outline 3D Drawing](#) | [Outline 3D STP](#)

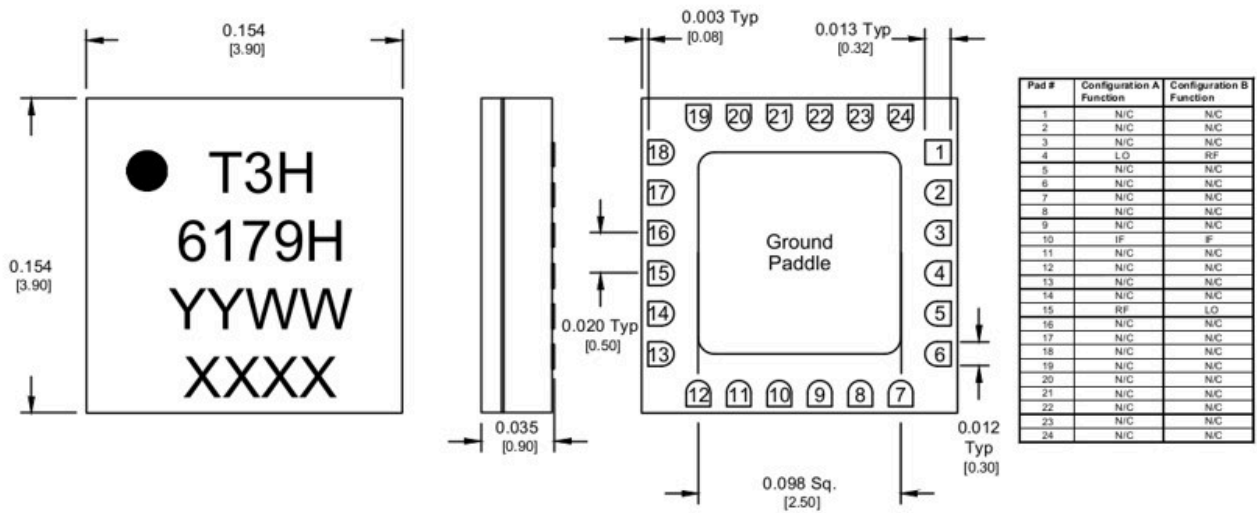

1. Substrate material is Ceramic.
2. All unconnected pads should be connected to PCB RF ground.
3. ENEPIG Plating/Finish: Ni: 8.89 micron|max, 1.27 micron min. Pd: 0.17 micron max, 0.07 micron min. Au: 0.254 micron max, 0.03 micron min.

**Footprint Image**

Download : [Footprint Drawing](#)

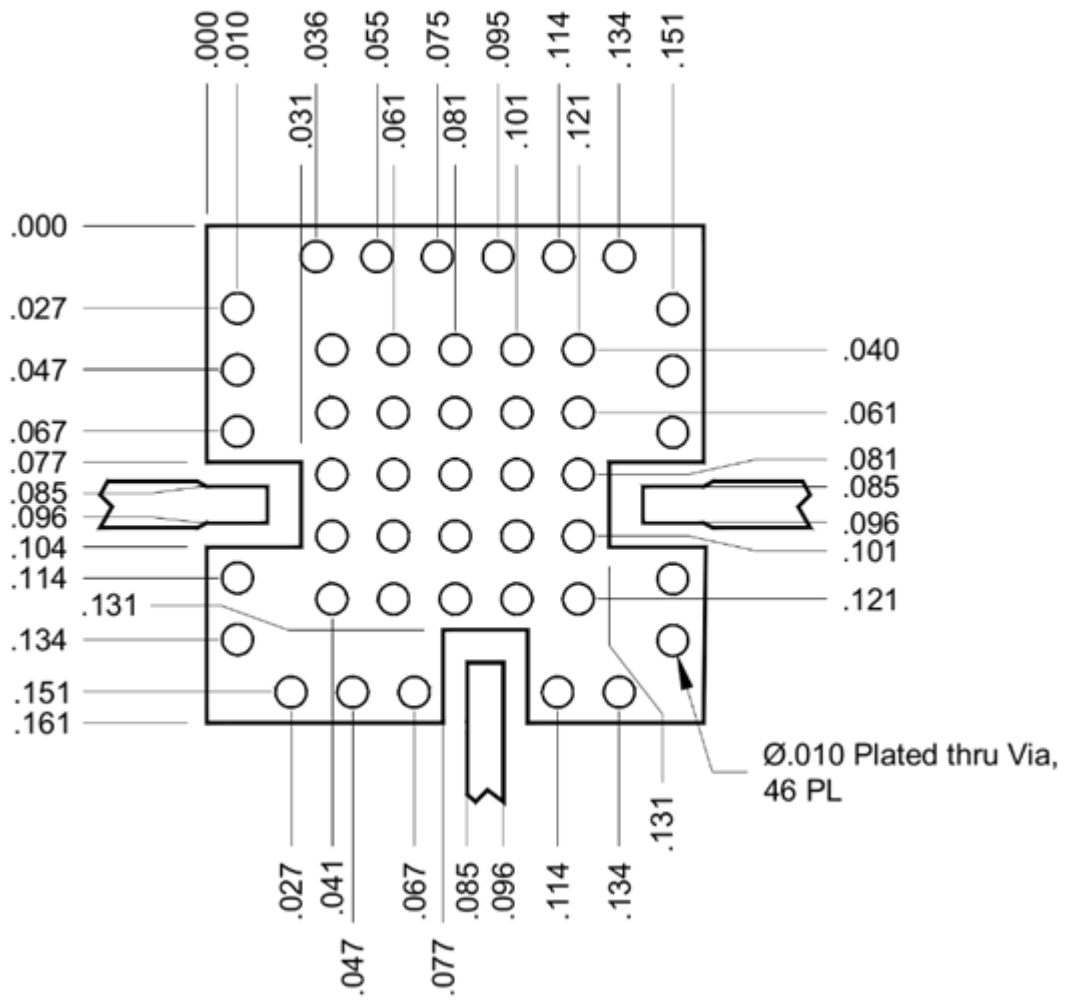

## Notes

1. Mixer Conversion Loss Plot IF frequency is 1 GHz unless otherwise specified.
2. Mixer Noise Figure typically measures within 0.5 dB of conversion loss for IF frequencies greater than 5 MHz.
3. Conversion Loss typically degrades less than 0.5 dB at +100°C and improves less than 0.5 dB at -55°C.
4. Unless otherwise specified, data is taken with highside, +20 dBm sine wave LO drive.
5. Square wave LO generated using 2x ADM1-0026PA with +10 dBm input into the first stage. LO Power reported in plots is of the fundamental tone only. Square wave LO power in plots is stepped down using broadband DC-40 GHz attenuators.
6. Specifications are subject to change without notice. Contact Marki Microwave for the most recent specifications and data sheets.
7. Catalog mixer circuits are continually improved. Configuration control requires custom mixer model numbers and specifications

Note: Exposure to maximum rating conditions for extended periods may reduce device reliability. There is no damage to device with only one parameter set at the limit and all other parameters set at or below their nominal value. Exceeding any of the limits listed here may result in permanent damage to the device.

## DISCLAIMER

MARKI MICROWAVE, INC., ("MARKI") PROVIDES TECHNICAL SPECIFICATIONS AND DATA (INCLUDING DATASHEETS), APPLICATION OR OTHER DESIGN ADVICE, WEB TOOLS, AND OTHER INFORMATION AND RESOURCES "AS IS" AND WITH ALL FAULTS. MARKI DISCLAIMS ALL WARRANTIES, EXPRESS OR IMPLIED, INCLUDING, WITHOUT LIMITATION, ANY IMPLIED WARRANTIES OF MERCHANTABILITY, FITNESS FOR A PARTICULAR PURPOSE, OR NON-INFRINGEMENT. These resources are intended for developers skilled in the art designing with Marki products. You are solely responsible for (1) selecting the appropriate products for your application, (2) designing, validating, and testing your application, and (3) ensuring your application meets applicable standards and other requirements. Marki makes no guarantee regarding the suitability of its products for any particular purpose, nor does Marki assume any liability whatsoever arising out of your use or application of any Marki product.

Marki grants you permission to use these resources only for development of an application that uses Marki products. Other reproduction or use of these resources is strictly prohibited. No license is granted to any other Marki intellectual property or to any third-party intellectual property. Marki reserves the right to make changes to the product(s) or information contained herein without notice.

MARKI MICROWAVE and T3 MIXER are trademarks or registered trademarks of Marki Microwave, Inc. All other trademarks used are the property of their respective owners.

© 2017, 2019, Marki Microwave, Inc