

MFBT-00002PSM

GaAs MMIC 4.5 - 16.5 GHz Tunable Filter

DEVICE OVERVIEW

General Description

The MFBT-00002PSM is a surface mount MMIC tunable filter for adaptive filtering applications. The MFBT-00002PSM offers separate low pass and high pass tuning capability, allowing users to create bandpass filters with variable center frequencies and % bandwidths. Performance features include low return loss in both the passband and stopband and low insertion loss, high stopband rejection, and high IP3 relative to other tunable filters. The MFBT-00002PSM is available as a 4x4mm plastic QFN, replacing much larger switched filter banks.

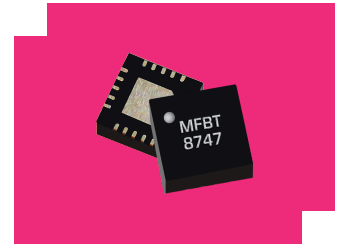

[Download s-parameters here](#)

Features

- Highly configurable filter
- Low loss
- Excellent return loss
- High IP3

Applications

- Test and Measurement Equipment
- SATCOM
- Radar
- Electronic Warfare
- Digital Communications

Functional Block Diagram

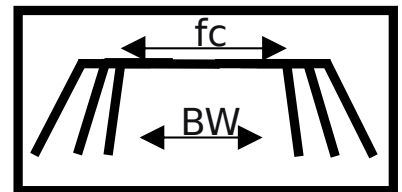

Part Ordering Options

Part Number	Description	Package	Green Status	Product Lifecycle	Export Classification
MFBT-00002PSM	GaAs MMIC 4.5 - 16.5 GHz Tunable Filter	QFN	REACH RoHS	Released	3A001.b.5.a
EVB-MFBT-00002P	GaAs MMIC 4.5 - 16.5 GHz Tunable Filter	EVB	REACH RoHS	Released	3A001.b.5.a

Table Of Contents

- **Device Overview**
 - General Description
 - Features
 - Applications
 - Functional Block Diagram
- **Port Configuration and Functions**
 - Port Diagram
 - Port Functions
- **Revision History**
- **Specifications**
 - Absolute Maximum Ratings
 - Package Information
 - Recommended Operating Conditions
 - Electrical Specifications
 - Typical Performance Plots
- **Mechanical Data**
 - Outline Drawing
- **Footprint Image**
- **Evaluation Board**
 - Evaluation Board Outline Drawing

Revision History

Revision Code	Revision Date	Comment
-	2023-12-05	Datasheet Initial Release



Port Configuration and Functions

Port Diagram

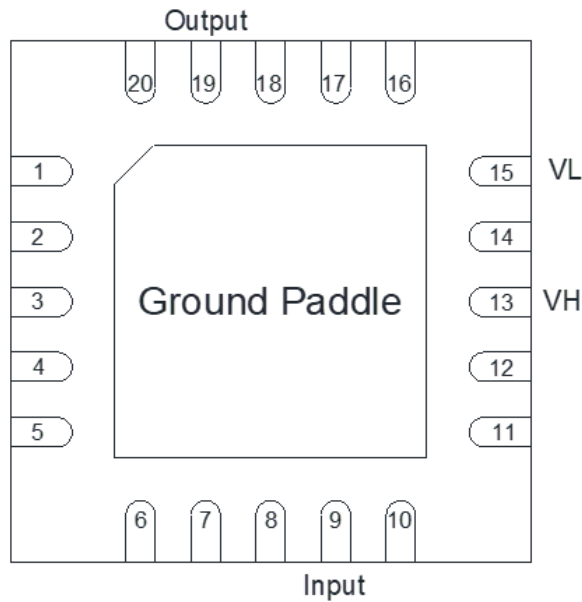
A top-down x-ray view of the MFBT-00002PSM package outline drawing is shown below. The MMIC bandpass filters are symmetrical allowing Pin 9 or Pin 19 to be used as the input.

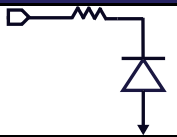
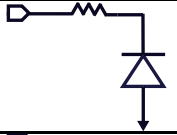
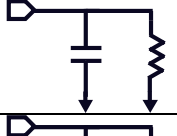

Port Functions

Port	Function	Description	DC Equivalent Circuit
Pin 13	VH	Pin 13 sets the high pass cutoff frequency tuning voltage and is diode connected and matched to 50Ω. The high pass cutoff frequency increases with increasing voltage.	
Pin 15	VL	Pin 15 sets the low pass cutoff frequency tuning voltage and is diode connected and matched to 50Ω. The low pass cutoff frequency increases with increasing voltage.	
Pin 19	Output	Pin 19 is connected to ground through an RC network with a large resistor value and matched to 50Ω.	
Pin 9	Input	Pin 9 is connected to ground through an RC network with a large resistor value and matched to 50Ω.	

Specifications

Absolute Maximum Ratings

The Absolute Maximum Ratings indicate limits beyond which damage may occur to the device. All limits are individual and should not be met in parallel, doing so will degrade the lifetime of the device. If these limits are exceeded, the device may be inoperable or have a reduced lifetime.

Parameter	Maximum Rating	Unit
Maximum Operating Temperature	85	°C
Maximum Storage Temperature	125	°C
Minimum Operating Temperature	-55	°C
Minimum Storage Temperature	-65	°C
Power Handling, at any Port	36	dBm

Package Information

Parameter	Details	Rating
Dimensions	-	4 x 4 mm
Moisture Sensitivity Level	-	MSL 1

Recommended Operating Conditions

The Recommended Operating Conditions indicate the limits, inside which the device should be operated, to guarantee the performance given in Electrical Specifications. Operating outside these limits may not necessarily cause damage to the device, but the performance may degrade outside the limits of the electrical specifications. For limits, above which damage may occur, see Absolute Maximum Ratings.

Parameter	Min	Nominal	Max	Unit
VL Tuning Voltage	0	-	16	V
VH Tuning Voltage	0	-	16	V

Electrical Specifications

The electrical specifications apply at TA=+25°C in a 50Ω system. Typical data shown is for the filter in a PSM package with a sine wave input applied to Pin 9. Bias voltage is VL/VH unless otherwise specified. Min and Max limits are guaranteed at TA=+25°C.

Parameter	Test Conditions	Minimum Frequency (GHz)	Maximum Frequency (GHz)	Min	Typ	Max	Unit
Center Frequency	-	-	-	5.5	-	15.5	GHz
Highside Rejection at 1.5*fc	-	-	-	-	35	-	dB
Impedance	-	-	-	-	50	-	Ω
Insertion Loss @ F ₀	-	5.5	15.5	-	6.5	-	dB
Lowside Rejection at 0.4*fc	-	-	-	-	35	-	dB
Output IP3	-	-	-	-	33	-	dBm
Passband Return Loss	-	4.5	16.5	-	15	-	dB
Tuning Voltage - VH, VL	-	-	-	0	-	16	V
Usable 3dBc Passband	-	-	-	4.5	-	16.5	GHz
-	8V/8V	-	-	-	34	-	dBm

Typical Performance Plots

Specifications guaranteed from -55 to +85°C, measured in a 50-Ohm system. All plots are deembedded to the device pads unless otherwise noted.

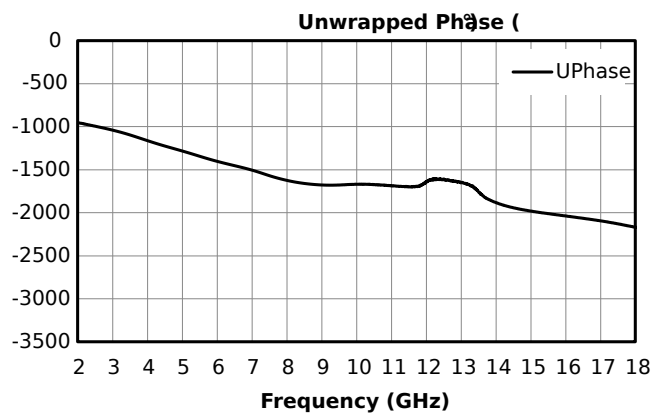
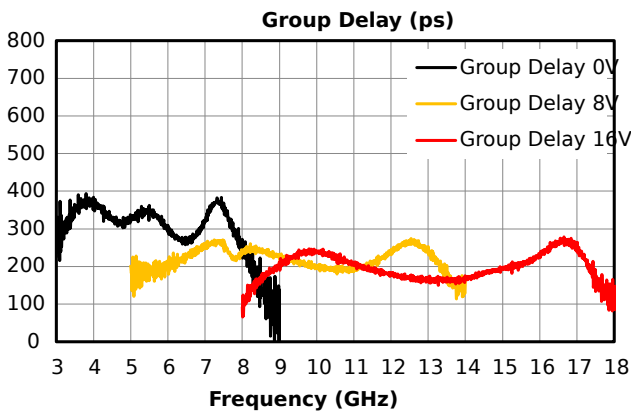
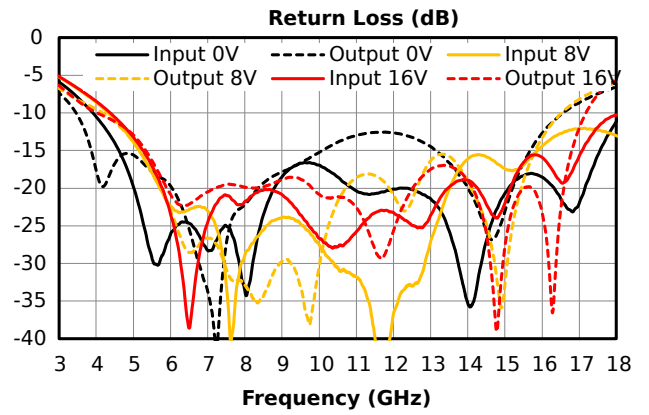
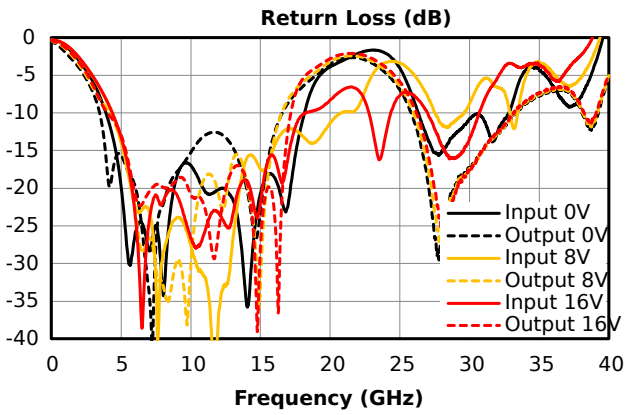
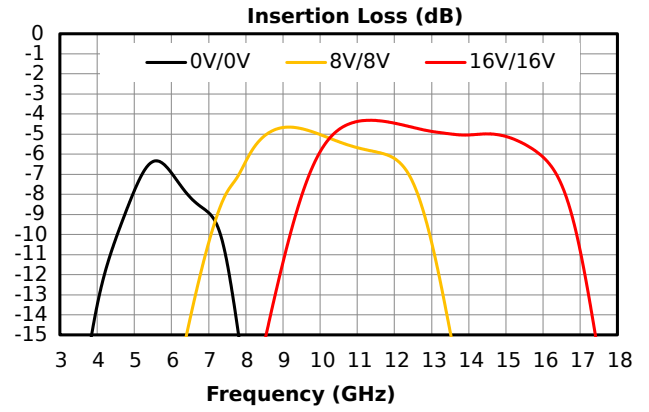
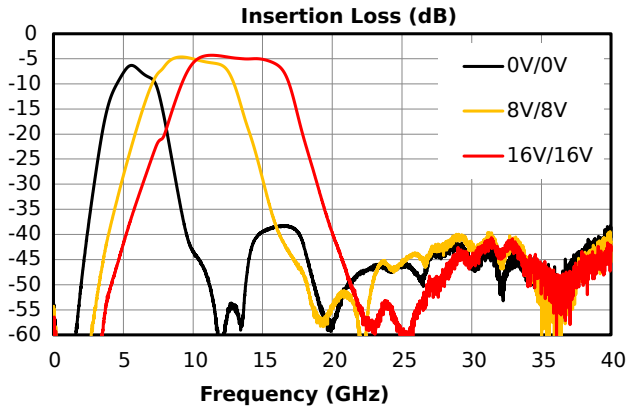

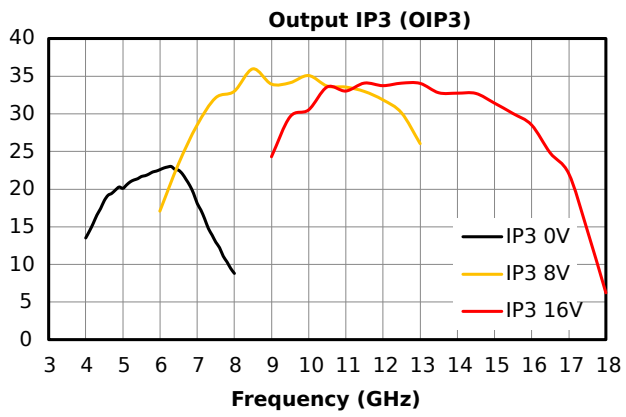

OIP3 measured on evaluation board with losses embedded

Mechanical Data

Outline Drawing

Download : [Outline 2D Drawing](#) | [Outline 3D Drawing](#)

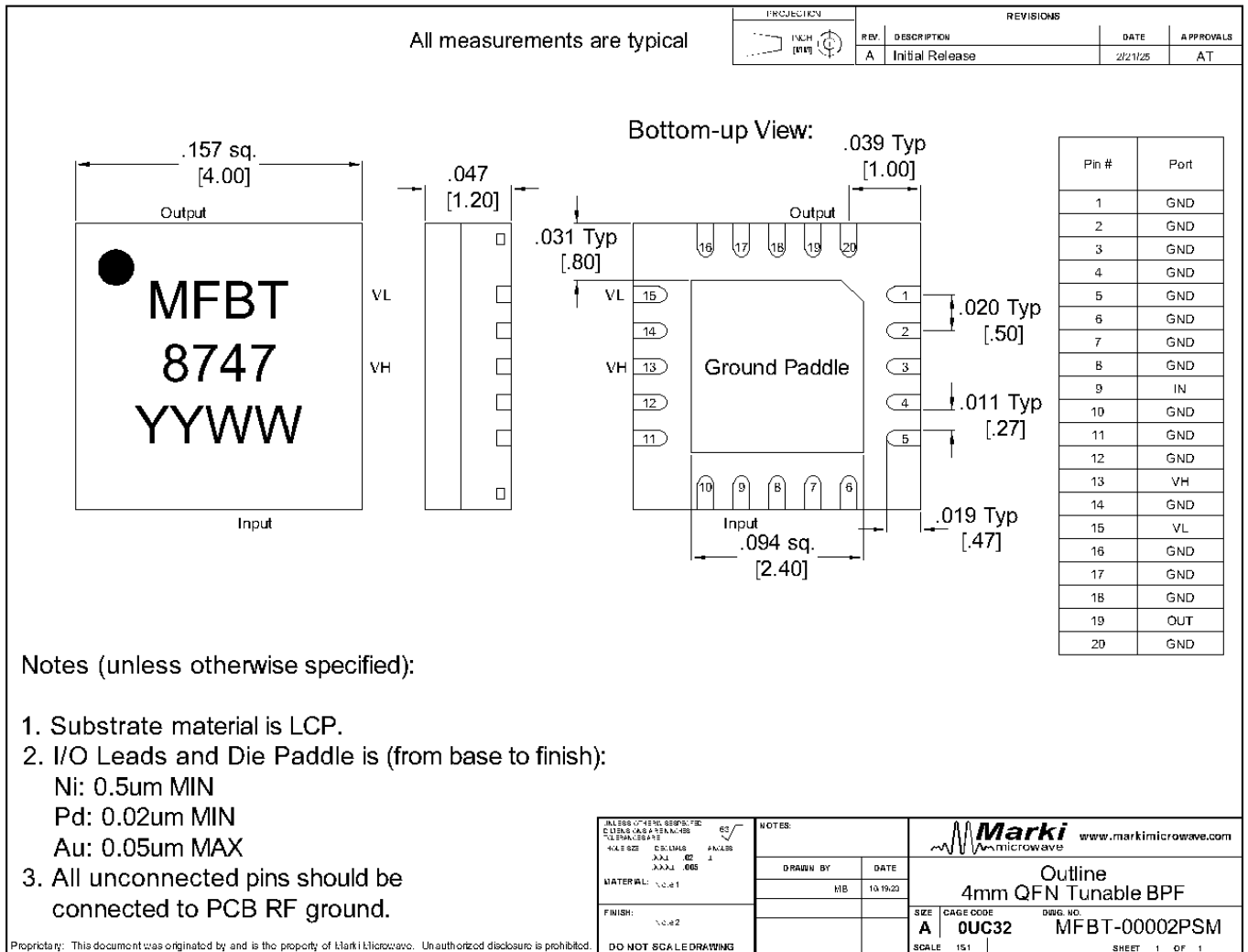

MFBT-00002PSM

GaAs MMIC 4.5 - 16.5 GHz Tunable Filter

Footprint Image

Download : [Footprint Drawing](#)

Pin #	Port
1	GND
2	GND
3	GND
4	GND
5	GND
6	GND
7	GND
8	GND
9	IN
10	GND
11	GND
12	GND
13	VH
14	GND
15	VL
16	GND
17	GND
18	GND
19	OUT
20	GND

QFN 4mm Sample Drawing X-Ray view

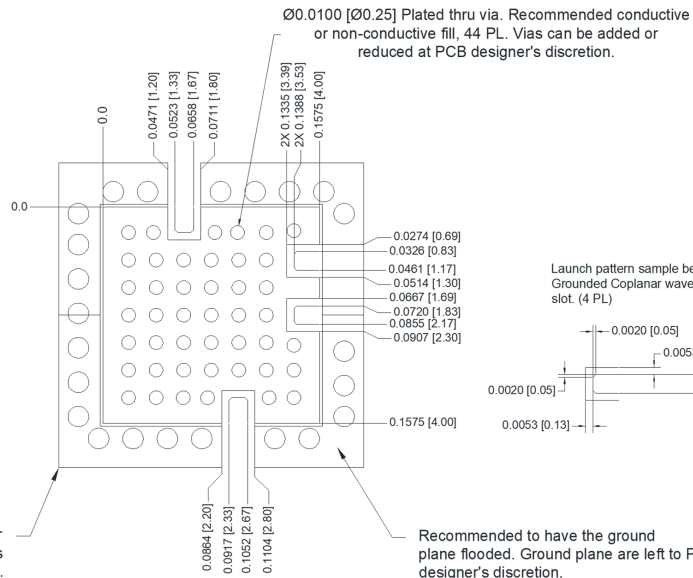
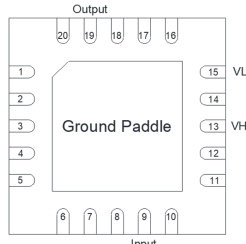

Recommended to have solder mask around the perimeter of the QFN border for better reflow alignment. Thickness of solder mask is left to PCB designer's discretion.

Recommended to have the ground plane flooded. Ground plane are left to PCB designer's discretion.

The landing pattern is to be used on Material Rogers 4003 008" Thick, $\frac{1}{2}$ Oz Cu both sides.

Evaluation Board - Outline Drawing

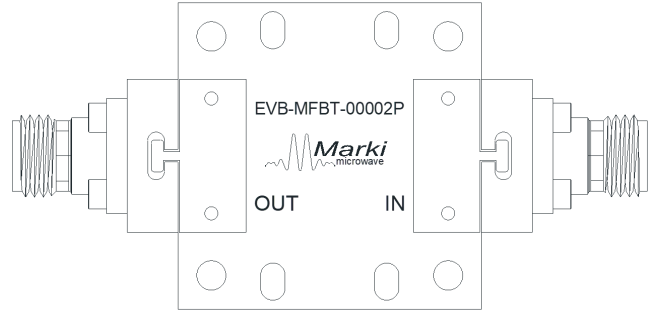
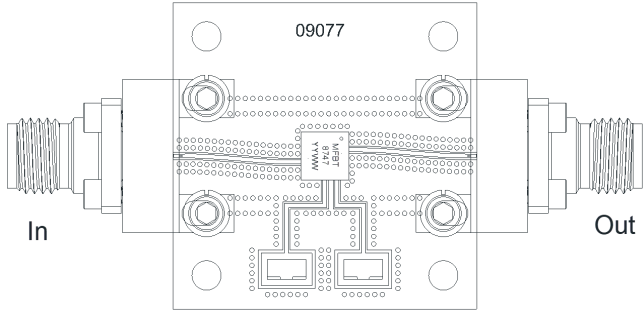

DISCLAIMER

MARKI MICROWAVE, LLC., ("MARKI") PROVIDES TECHNICAL SPECIFICATIONS AND DATA (INCLUDING DATASHEETS), APPLICATION OR OTHER DESIGN ADVICE, WEB TOOLS, AND OTHER INFORMATION AND RESOURCES "AS IS" AND WITH ALL FAULTS. MARKI DISCLAIMS ALL WARRANTIES, EXPRESS OR IMPLIED, INCLUDING, WITHOUT LIMITATION, ANY IMPLIED WARRANTIES OF MERCHANTABILITY, FITNESS FOR A PARTICULAR PURPOSE, OR NON-INFRINGEMENT.

These resources are intended for developers skilled in the art designing with Marki products. You are solely responsible for (1) selecting the appropriate products for your application, (2) designing, validating, and testing your application, and (3) ensuring your application meets applicable standards and other requirements. Marki makes no guarantee regarding the suitability of its products for any particular purpose, nor does Marki assume any liability whatsoever arising out of your use or application of any Marki product.

Marki grants you permission to use these resources only for development of an application that uses Marki products. Other reproduction or use of these resources is strictly prohibited. No license is granted to any other Marki intellectual property or to any third-party intellectual property. Marki reserves the right to make changes to the product(s) or information contained herein without notice.

MARKI MICROWAVE and T3 MIXER are trademarks or registered trademarks of Marki Microwave, LLC. All other trademarks used are the property of their respective owners.

© 2023, Marki Microwave, LLC