

ADM-5974CH

Broadband Distributed Amplifier

DEVICE OVERVIEW

General Description

The ADM-5974CH is a broadband, moisture resistant MMIC LO buffer amplifier. The ADM-5974 provides efficient, optimized LO drive to all Marki mixers in band with no required negative bias or sequencing. It is built with a moisture resistant pHEMT process to allow the bare chip to pass biased HAST testing without a hermetic seal. Second harmonic rejection can be tuned to very low levels using the optional negative bias. The ADM-5974 can also be used as a broadband signal amplifier. The bare die features enhanced moisture resistance for improved reliability.

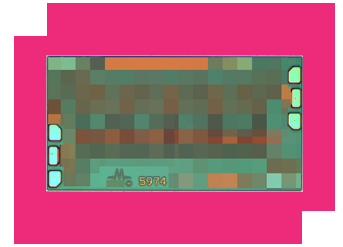

Features

- Optimized for use as a T3 LO buffer amplifier
- Fast <10 ps risetime
- 3rd and 5th Harmonic Generation
- Broadband 50 Ω Matching
- Unconditionally Stable
- Enhanced Moisture Resistance

Applications

N/A

Functional Block Diagram

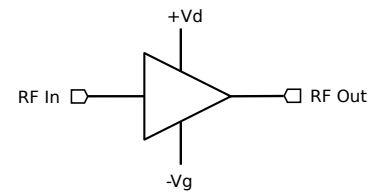

Part Ordering Options

Part Number	Description	Package	Green Status	Product Lifecycle	Export Classification
ADM-5974CH	Broadband Distributed Amplifier	CH	REACH RoHS	Released	3A001.b.2.d

Table Of Contents

- **Device Overview**
 - General Description
 - Features
 - Applications
 - Functional Block Diagram
- **Port Configuration and Functions**
 - Port Diagram
 - Port Functions
- **Revision History**
- **Specifications**
 - Absolute Maximum Ratings
 - Package Information
 - Electrical Specifications
 - Typical Performance Plots
- **Operation**
 - Application Information
- **Mechanical Data**
 - Outline Drawing

Revision History

Revision Code	Revision Date	Comment
-	2017-04-01	Datasheet initial Release
A	2019-07-01	Thermal Resistance Spec Corrected
B	2020-12-01	Added Max Junction Temperature Specification

Port Configuration and Functions

Port Diagram

Functional Diagram and Application Circuit

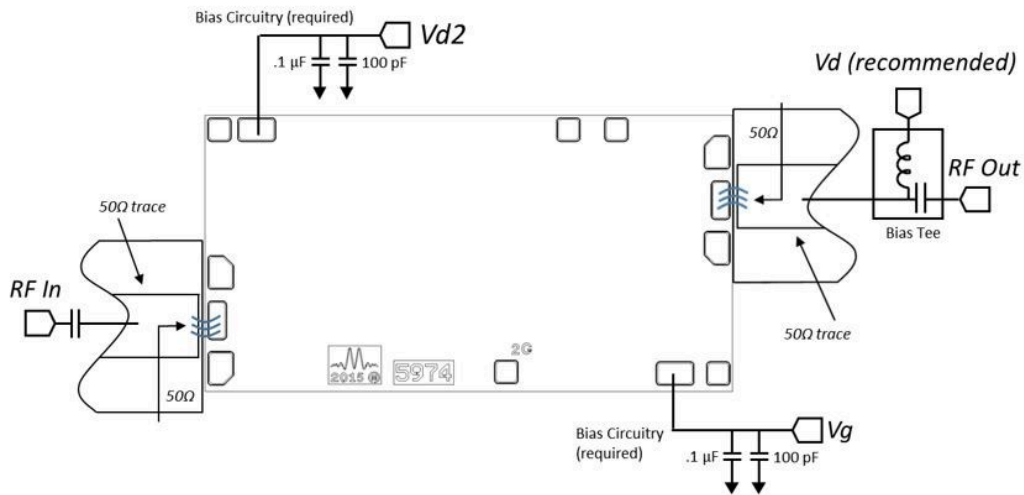

Port Functions

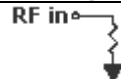
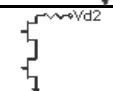
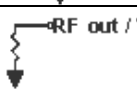
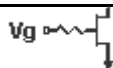
Port	Function	Description	DC Equivalent Circuit
GND	Gnd	Back of chip should be connected to RF/DC ground with low electrical and thermal resistance.	
RF In	RF Input	This pin is DC coupled and matched to 50 Ω.	
Vd2	Vd2	Optional drain bias port. External decoupling capacitors are required.	
Vd/RF Out	RF Out / Vd	This pad is DC coupled and matched to 50 Ω.	
Vg	Vg	Gate control for the amplifier. External decoupling capacitors are required.	

Specifications

Absolute Maximum Ratings

Parameter	Maximum Rating	Unit
Maximum Operating Temperature	85	°C
Maximum Storage Temperature	150	°C
Max Junction Temperature for MTTF of >1E6 hours	175	°C
Minimum Operating Temperature	-55	°C
Minimum Storage Temperature	-65	°C
Negative Bias Current	2	mA
Negative Bias Voltage	-2	V
Positive Bias Current	275	mA
Positive Bias Voltage	9	V
Power Dissipation	2	W
RF Input Power	20	dBm
Thermal Resistance	67	°C/W

Package Information

Parameter	Details	Rating
ESD	< 250 Volts	HBM Class 0
Dimensions	-	2.20x1.15mm

Electrical Specifications

Specifications measured in a 50-Ohm system.

Parameter	Test Conditions	Minimum Frequency (GHz)	Maximum Frequency (GHz)	Min	Typ	Max	Unit
Current Consumption	Vd: +5.0 to +7.0 Vg: -0.25 Volts	0	35	-	150	-	mA
Current Consumption	Vd: +5.0 to +7.0 Vg: 0 Volts	0	35	-	220	-	mA
Noise Figure	-	0	35	-	6	-	dB
Output IP3	-	0	35	-	27	-	dBm
Output P1dB	-	0	35	-	20	-	dBm
Phase Noise @ 10 kHz Offset	-	0	35	-	-153	-	dBc/Hz
Return Loss	-	0	35	-	16	-	dB
Saturated Output Power	With Negative Bias	0	35	-	22	-	dBm
Small Signal Gain	With Negative Bias	0	35	-	14	-	dB

Typical Performance Plots

+3, +7V Positive Bias, -0.25 Negative Bias

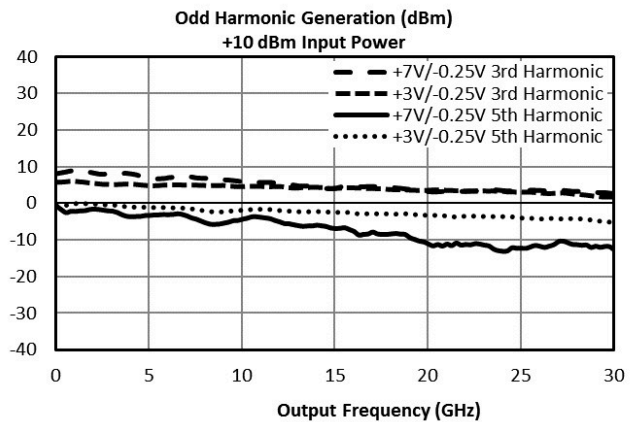
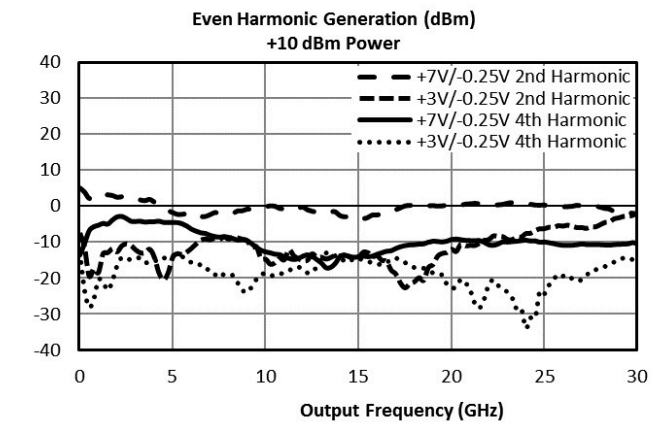
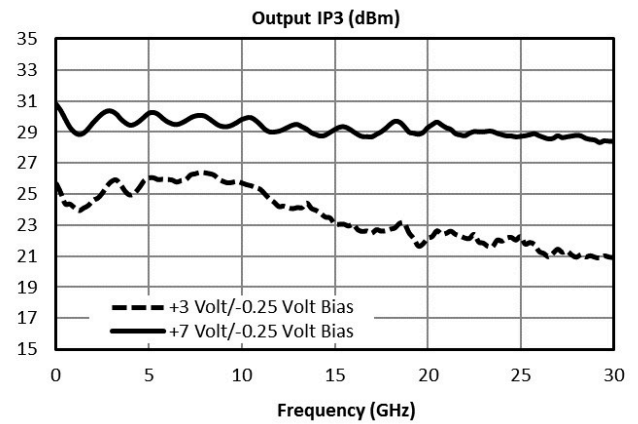
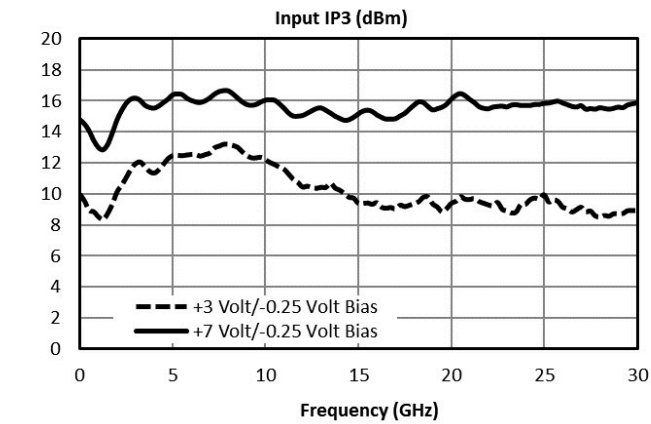
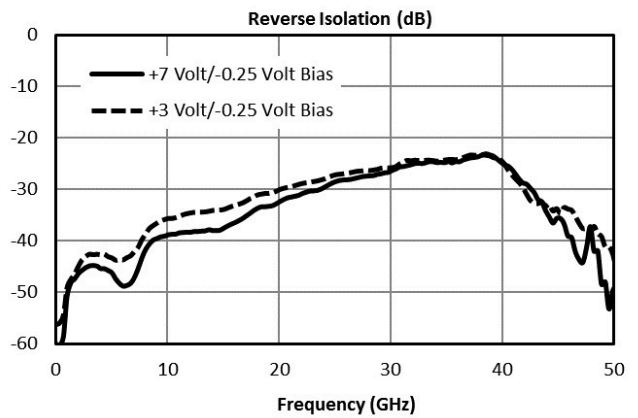
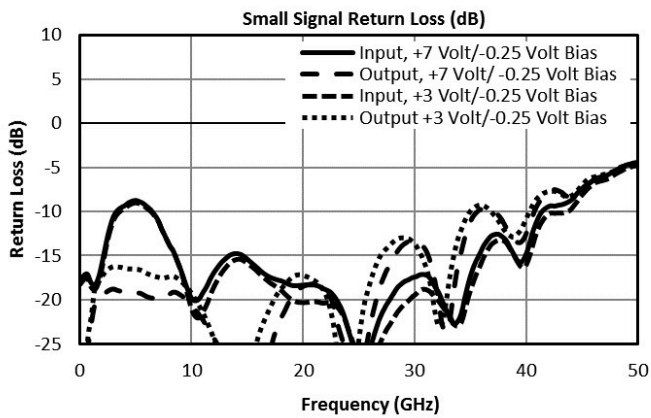
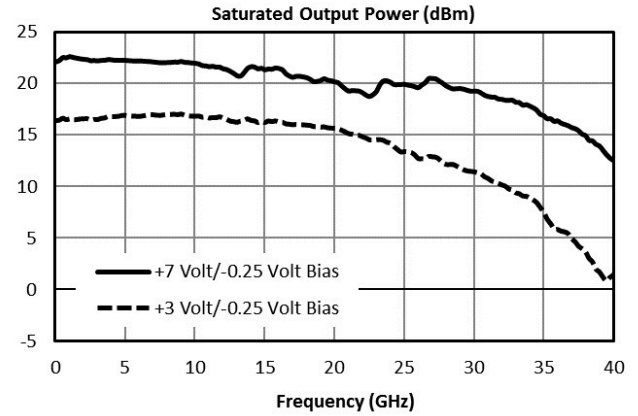
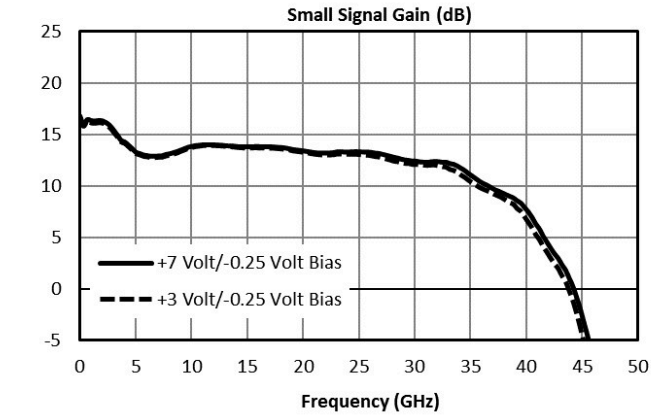

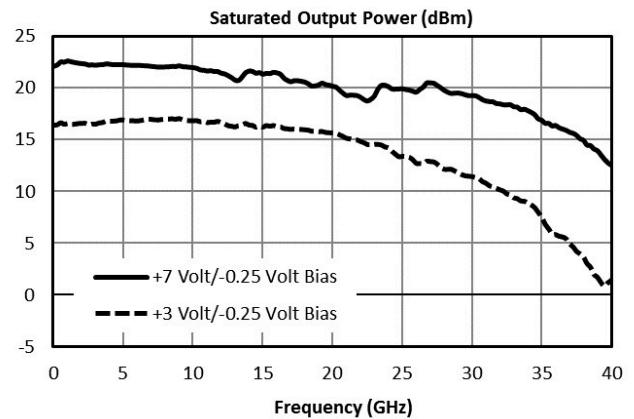
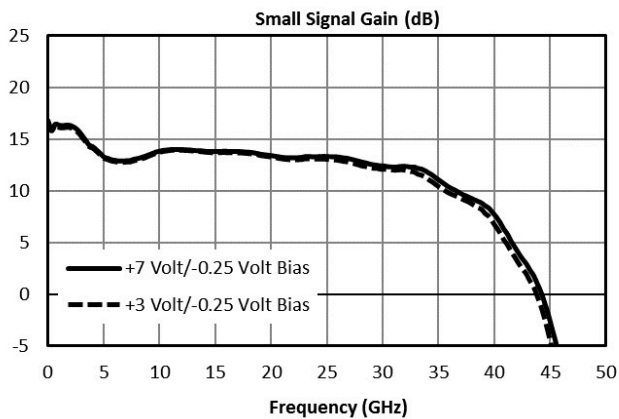
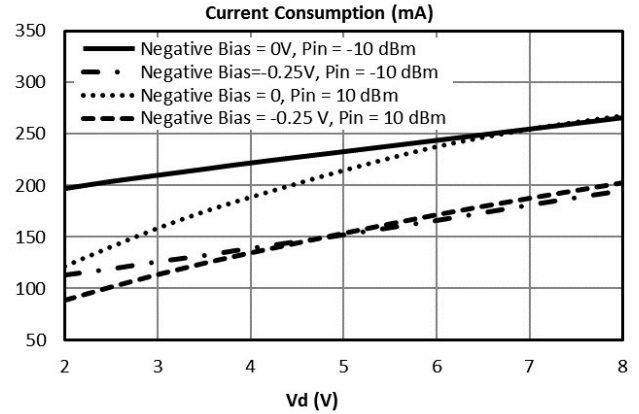
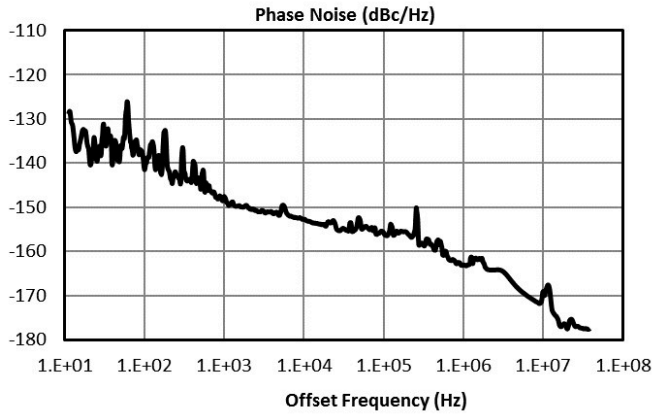
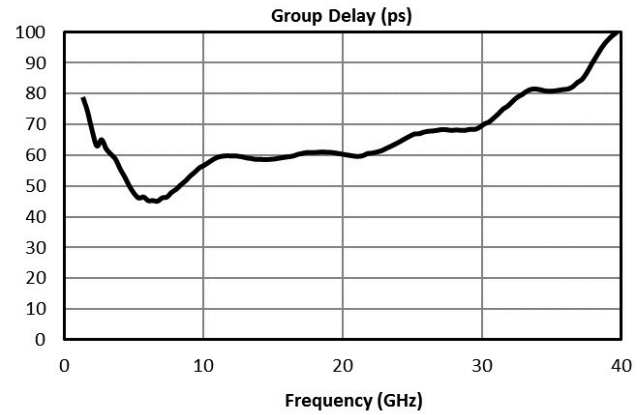
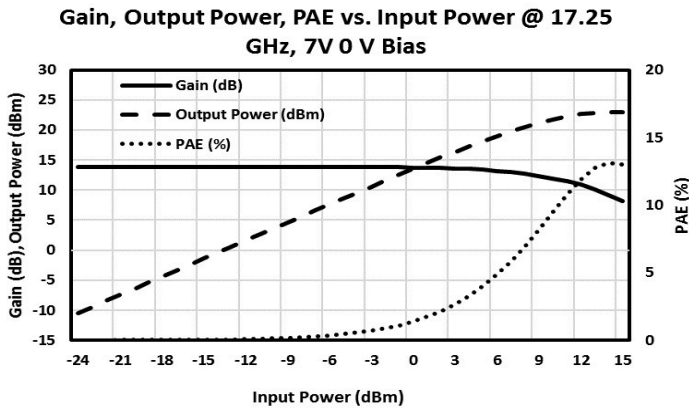
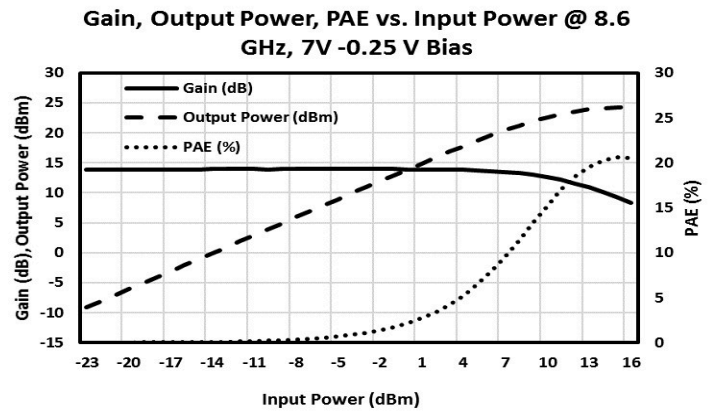
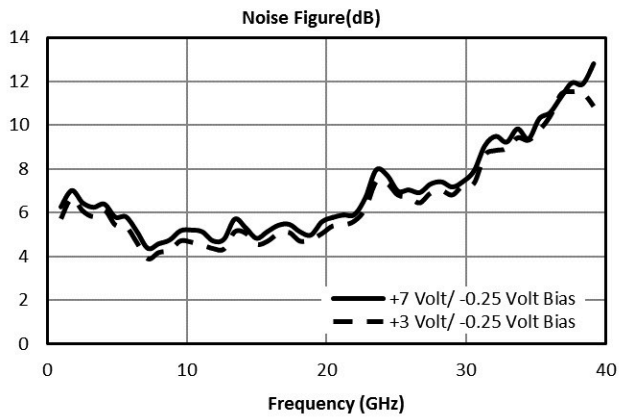

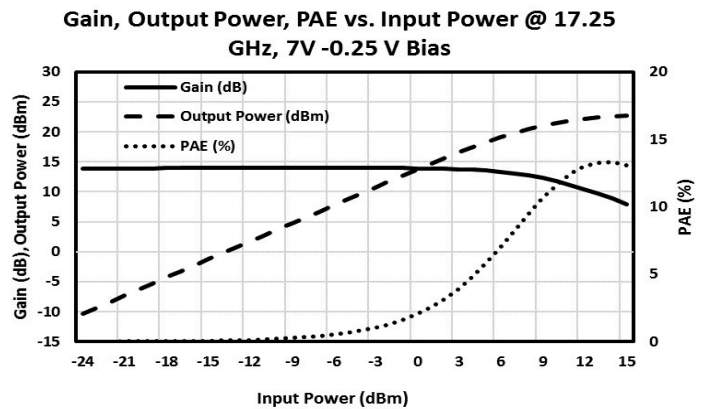
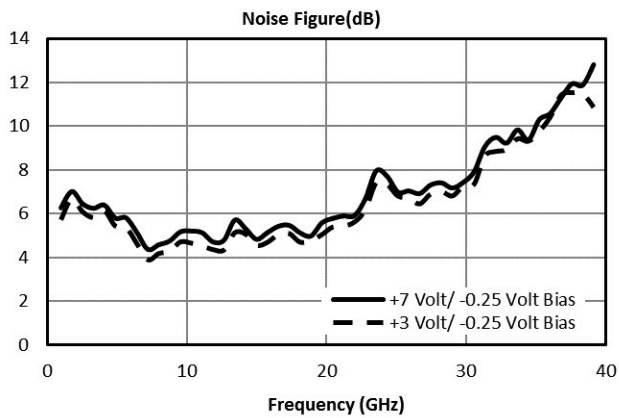
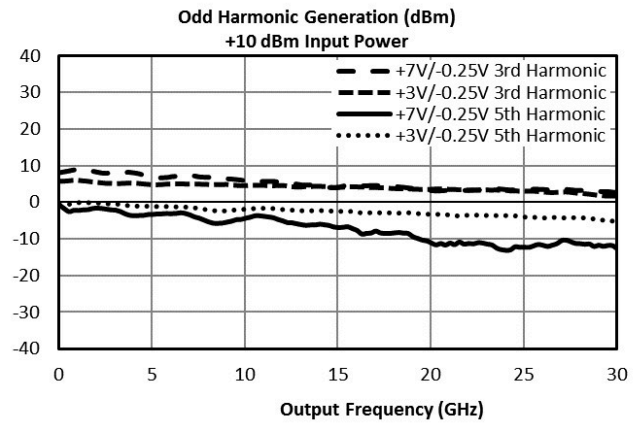
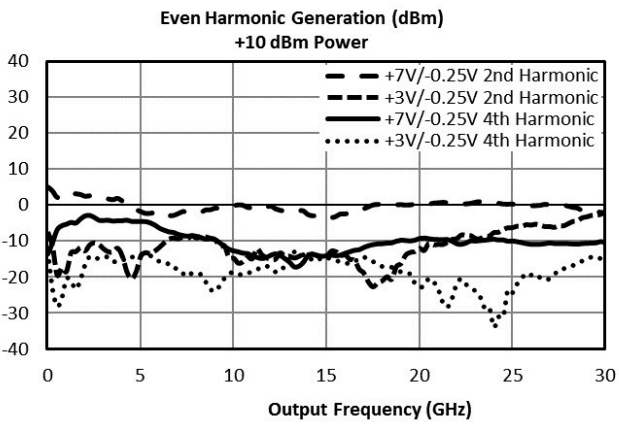
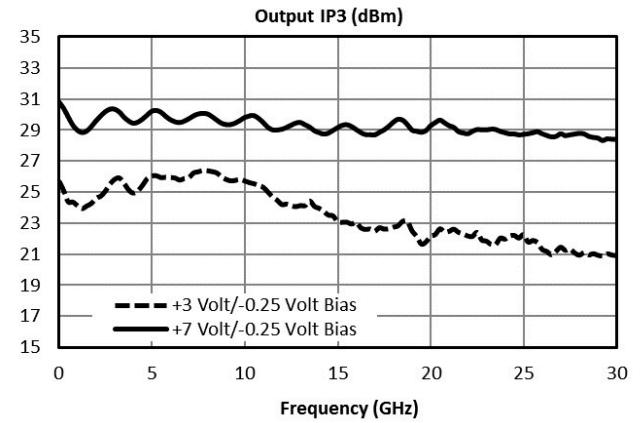
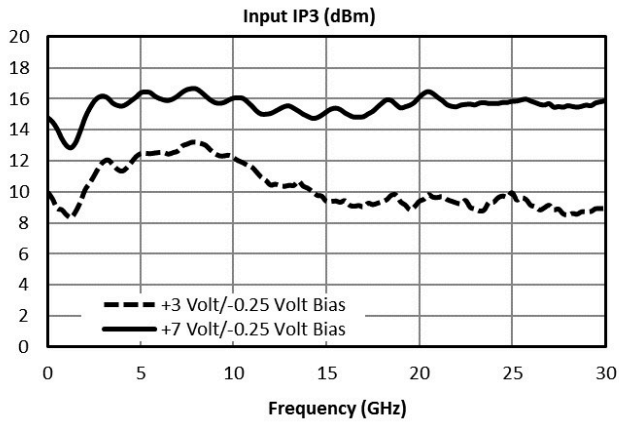
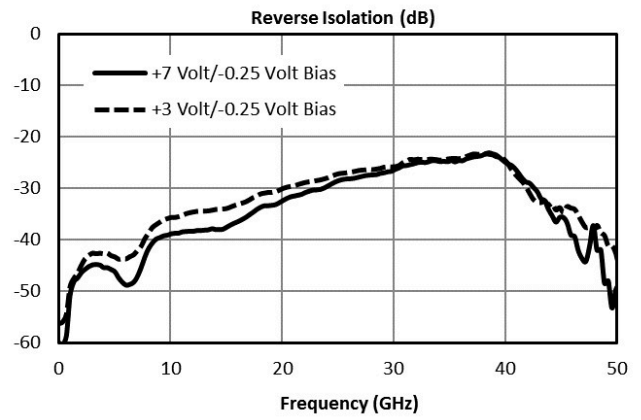
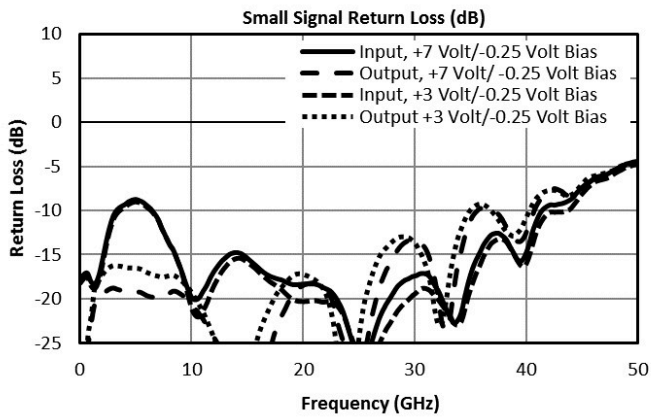

Gain, Output Power, PAE vs. Input Power @ 17.25 GHz, 7V -0.25 V Bias

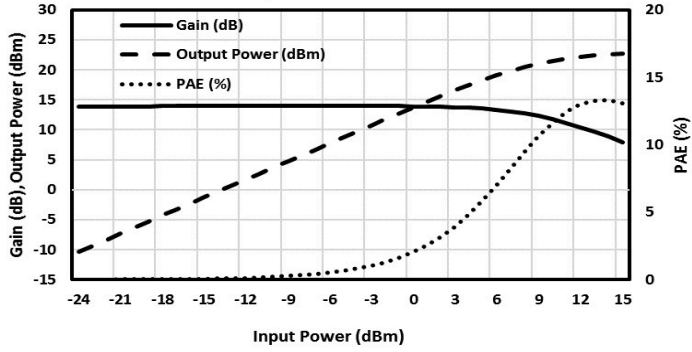

Application Information

Functional Diagram and Application Circuit

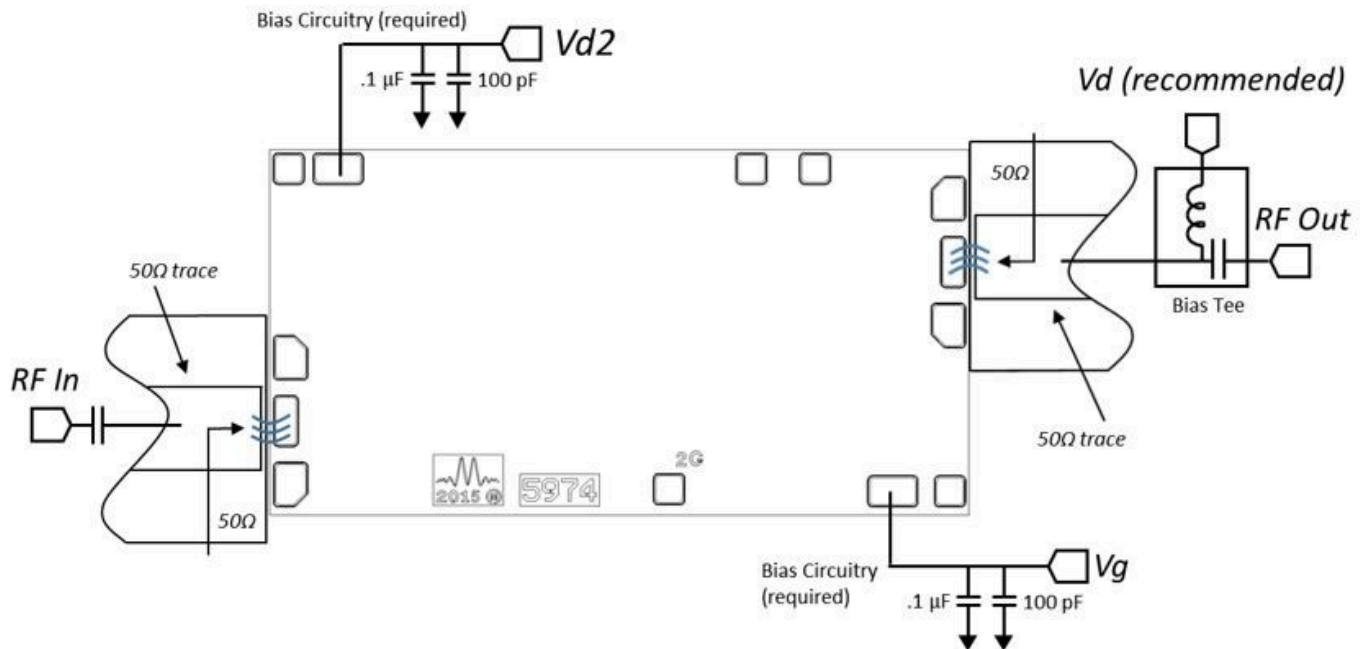

Biassing and Operation

RF In / RF Out – Input and output signals should be connected by 50 ohm microstrip or coplanar traces to well matched 50 ohm sources and loads. DC blocking capacitors and bias tees are required.

Vg – Negative gate voltage is optional to improve lifetime of the amplifier and reduce current consumption. Harmonic generation is also significantly affected by the negative gate voltage level. It may be supplied through the Vg pad or through the RF input pad using an external bias tee

Vd- It is recommended that bias voltage Vd is applied through a bias tee on the RF output, but bias supply can also be supplied to Vd through Vd2 pad if desired. This will result in increased operating temperature and slightly reduced gain and power output. Bias supply should be voltage limited below 9 V and current limited below 250 mA at all times. The operational bias voltage should be between 3 V and 7 V for full small-signal gain, or between 5 V and 7 V for full gain, linearity and power output. If bias tee on RF output is used, pad Vd2 voltage should be left unconnected (not grounded).

Bias Circuitry – The capacitors on the Vd and Vg lines prevent low frequency oscillation. They may be reduced or omitted in bias circuits with sufficient low-frequency loss. Designers are encouraged to experiment if they want to modify or omit the bias circuitry.

DC/RF Ground – The back of the chip should be connected to a low noise RF and DC ground with very low electrical and thermal resistance for high frequency operation and thermal heat sinking.

DISCLAIMER

MARKI MICROWAVE, LLC., ("MARKI") PROVIDES TECHNICAL SPECIFICATIONS AND DATA (INCLUDING DATASHEETS), APPLICATION OR OTHER DESIGN ADVICE, WEB TOOLS, AND OTHER INFORMATION AND RESOURCES "AS IS" AND WITH ALL FAULTS. MARKI DISCLAIMS ALL WARRANTIES, EXPRESS OR IMPLIED, INCLUDING, WITHOUT LIMITATION, ANY IMPLIED WARRANTIES OF MERCHANTABILITY, FITNESS FOR A PARTICULAR PURPOSE, OR NON-INFRINGEMENT.

These resources are intended for developers skilled in the art designing with Marki products. You are solely responsible for (1) selecting the appropriate products for your application, (2) designing, validating, and testing your application, and (3) ensuring your application meets applicable standards and other requirements. Marki makes no guarantee regarding the suitability of its products for any particular purpose, nor does Marki assume any liability whatsoever arising out of your use or application of any Marki product.

Marki grants you permission to use these resources only for development of an application that uses Marki products. Other reproduction or use of these resources is strictly prohibited. No license is granted to any other Marki intellectual property or to any third-party intellectual property. Marki reserves the right to make changes to the product(s) or information contained herein without notice.

MARKI MICROWAVE and T3 MIXER are trademarks or registered trademarks of Marki Microwave, LLC. All other trademarks used are the property of their respective owners.

© 2017, 2019 - 2020, Marki Microwave, LLC