

AMM-10220PSM

2 - 26 GHz GaAs Surface Mount LO Driver Amplifier

DEVICE OVERVIEW

General Description

The AMM-10220PSM is a surface-mount amplifier suitable for use as a single tone driver or general-purpose gain block. It can drive an L or H diode mixer from 2 to 26 GHz. This amplifier also has exceptionally low input and output reflections, and a low 2.7 dB typical noise figure from 8 to 18 GHz. Additionally, this amplifier exhibits a positive gain slope to equalize frequency dependent losses. The AMM-10220PSM is packaged in a compact 5 mm QFN for surface mount integration onto printed circuit boards.

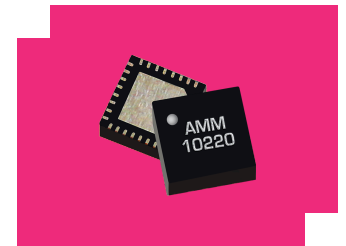

Features

- +14 dB Small Signal Gain with Positive Slope
- Excellent 18 dB return losses
- +28 dBm Output IP3
- Compact 5mm QFN package
- Simple application circuit

Applications

- Mobile test and measurement equipment
- Radar and satellite communications
- Driver Amplifier for H and S - Diode Mixers
- Electronic Warfare

Functional Block Diagram

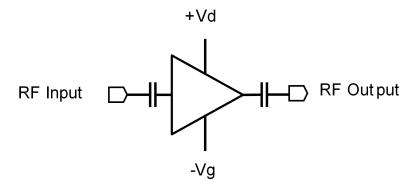

Part Ordering Options

Part Number	Description	Package	Green Status	Product Lifecycle	Export Classification
AMM-10220PSM	2 - 26 GHz GaAs Surface Mount LO Driver Amplifier	QFN	REACH RoHS	Released	EAR99
EVB-AMM-10220P	Evaluation Board, AMM-10220PSM, 2 - 26 GHz GaAs Surface Mount LO Driver Amplifier	-	REACH RoHS	Released	-

AMM-10220PSM

2 - 26 GHz GaAs Surface Mount LO Driver Amplifier

Table Of Contents

- **Device Overview**
 - General Description
 - Features
 - Applications
 - Functional Block Diagram
- **Port Configuration and Functions**
 - Port Diagram
 - Port Functions
- **Revision History**
- **Specifications**
 - Absolute Maximum Ratings
 - Package Information
 - Recommended Operating Conditions
 - Sequencing Requirements
 - Electrical Specifications
 - Typical Performance Plots
 - Typical Performance Plots, Over Temp
- **Operation**
 - Application Circuit
 - Application Circuit Description
- **Mechanical Data**
 - Outline Drawing
- **Footprint Image**
- **Evaluation Board**
 - Evaluation Board Outline Drawing

Revision History

Revision Code	Revision Date	Comment
-	2025-09-02	Initial Release

Port Configuration and Functions

Port Diagram

A port diagram of the AMM-10220PSM QFN package is shown below (X-ray view from the top).

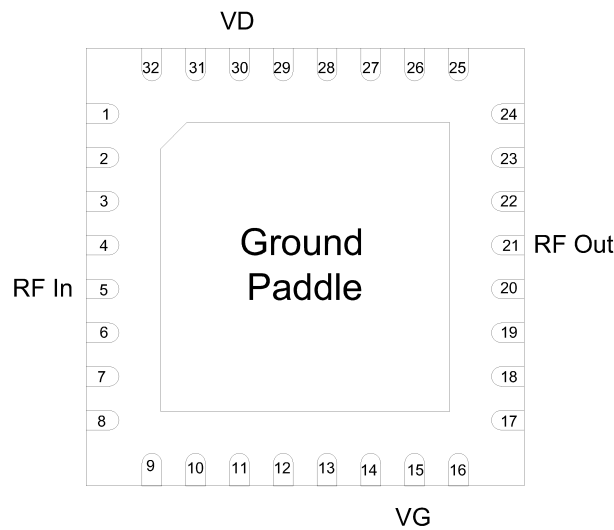

Port Functions

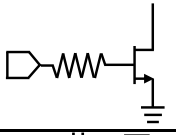
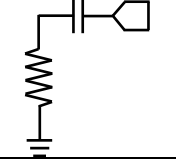
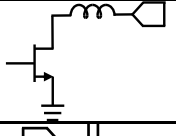
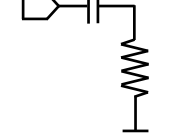
Port	Function	Description	Equivalent Circuit for Package
Pin 1-4, 6-14, 16-20, 22-29, 31, 32, Paddle	Ground	These pins should be connected to ground. Package ground paddle must be connected to a DC/RF ground potential with high thermal and electrical conductivity.	-
Pin 15	Vg	Pin 15 provides a required negative bias which controls the power supply currents to the amplifier. More negative voltages decrease supply current. Apply gate bias voltage Vg before applying drain power supply.	
Pin 21	RF Output	Pin 21 is the RF Output port of the amplifier. It is DC blocked, and RF matched to 50 Ω.	
Pin 30	Vd	Pin 30 provides the main power supply for the amplifier. Apply gate bias voltage Vg before applying drain power supply.	
Pin 5	RF Input	Pin 5 is the RF Input port of the amplifier die. It is internally DC blocked and RF matched to 50 Ω.	

Specifications

Absolute Maximum Ratings

The Absolute Maximum Ratings indicate limits beyond which damage may occur to the device. If any one of these limits are exceeded, the device may become inoperable or have a reduced lifetime.

Parameter	Maximum Rating	Unit
Drain Current (RF Applied)	130	mA
Drain Supply Voltage (Vd)	6	V
Gate Voltage (Vg)	-1	V
Maximum Operating Temperature for MTTF > 1E6 hours	85	°C
Maximum Storage Temperature	150	°C
Minimum Operating Temperature for MTTF > 1E6 hours	-55	°C
Minimum Storage Temperature	-65	°C
RF Input Power	20	dBm

Package Information

Parameter	Details	Rating
Dimensions	-	5 x 5 mm
Moisture Sensitivity Level	-	MSL 1

Recommended Operating Conditions

Datasheet operating parameters are taken and guaranteed using constant voltage biasing with TA = 25 °C, Vd = 5 V, Idq = 74 mA, and 50 Ω matched input and output. Adjust Vg from -1 V to -0.3 V max to achieve Idq = 74 mA typical.

Parameter	Min	Nominal	Max	Unit
Negative Bias Voltage (Vg)	-0.5	-0.4	-0.3	V
Positive DC Current (Id) (No RF Input)	-	74	-	mA
Positive DC Voltage (Vd)	-	5	-	V
Operating Temperature	-40	25	85	°C

Sequencing Requirements

Turn-on Procedure if required biases are unknown:

1. Apply -1 V to Vg.
2. Apply desired Vd.
3. Increase Vg voltage towards -0.3 V until Id = 74 mA.
4. Apply RF input power.

Turn-on Procedure if required biases are known:

1. Apply desired Vg (previously determined to produce 74 mA Idq).
2. Apply desired Vd.
3. Apply RF input power.

Turn-off Procedure:

1. Turn off RF input power.
2. Turn off Vd.
3. Turn off Vg.

Electrical Specifications

Unless otherwise specified, electrical specifications apply at TA=+25°C, Vd = 5 V, Idq=74 mA (where Idq is the drain current with no RF applied), Vg set as required to achieve Idq = 74 mA in a 50 Ω system.

Parameter	Test Conditions	Minimum Frequency (GHz)	Maximum Frequency (GHz)	Min	Typ	Max	Unit
DC Supply Quiescent Current (Idq)	Vd = 5 V, Vg = -0.4V, No RF Applied	-	-	-	74	-	mA
Small Signal Gain	Vd = 5 V, Vg set to achieve Idq = 74 mA, Pin = -20 dBm	2	8	-	14	-	dB
Small Signal Gain	Vd = 5 V, Vg set to achieve Idq = 74 mA, Pin = -20 dBm	8	18	-	14.5	-	dB
Small Signal Gain	Vd = 5 V, Vg set to achieve Idq = 74 mA, Pin = -20 dBm	18	26	-	16	-	dB
Reverse Isolation	Vd = 5 V, Vg set to achieve Idq = 74 mA, Pin = -20 dBm	2	8	-	53	-	dB
Reverse Isolation	Vd = 5 V, Vg set to achieve Idq = 74 mA, Pin = -20 dBm	8	18	-	43	-	dB
Reverse Isolation	Vd = 5 V, Vg set to achieve Idq = 74 mA, Pin = -20 dBm	18	26	-	33	-	dB
Input Return Loss	Vd = 5 V, Vg set to achieve Idq = 74 mA, Pin = -20 dBm	2	8	-	17	-	dB
Input Return Loss	Vd = 5 V, Vg set to achieve Idq = 74 mA, Pin = -20 dBm	8	18	-	16	-	dB
Input Return Loss	Vd = 5 V, Vg set to achieve Idq = 74 mA, Pin = -20 dBm	18	26	-	14	-	dB
Output Return Loss	Vd = 5 V, Vg set to achieve Idq = 74 mA, Pin = -20 dBm	2	8	-	18	-	dB
Output Return Loss	Vd = 5 V, Vg set to achieve Idq = 74 mA, Pin = -20 dBm	8	18	-	18	-	dB
Output Return Loss	Vd = 5 V, Vg set to achieve Idq = 74 mA, Pin = -20 dBm	18	26	-	14	-	dB
Output IP3	Vd = 5 V, Vg set to achieve Idq = 74 mA, Pin = -15 dBm per tone, 10 MHz tone spacing	2	8	-	28	-	dBm
Output IP3	Vd = 5 V, Vg set to achieve Idq = 74 mA, Pin = -15 dBm per tone, 10 MHz tone spacing	8	18	-	28	-	dBm
Output IP3	Vd = 5 V, Vg set to achieve Idq = 74 mA, Pin = -15 dBm per tone, 10 MHz tone spacing	18	26	-	24	-	dBm
Input IP3	Vd = 5 V, Vg set to achieve Idq = 74 mA, Pin = -15 dBm per tone, 10 MHz tone spacing	2	8	-	15	-	dBm
Input IP3	Vd = 5 V, Vg set to achieve Idq = 74 mA, Pin = -15 dBm per tone, 10 MHz tone spacing	8	18	-	13.5	-	dBm
Input IP3	Vd = 5 V, Vg set to achieve Idq = 74 mA, Pin = -15 dBm per tone, 10 MHz tone spacing	18	26	-	7.5	-	dBm
Output P1dB	Vd = 5 V, Vg set to achieve Idq = 74 mA	2	14	-	18	-	dBm
Output P1dB	Vd = 5 V, Vg set to achieve Idq = 74 mA	14	26	-	15.5	-	dBm
Noise Figure	Vd = 5 V, Vg set to achieve Idq = 74 mA, Pin = -20 dBm	2	8	-	3.4	-	dB
Noise Figure	Vd = 5 V, Vg set to achieve Idq = 74 mA, Pin = -20 dBm	8	18	-	2.7	-	dB
Noise Figure	Vd = 5 V, Vg set to achieve Idq = 74 mA, Pin = -20 dBm	18	26	-	3.6	-	dB

AMM-10220PSM

2 - 26 GHz GaAs Surface Mount LO Driver Amplifier

Typical Performance Plots

Performance plots have PCB trace losses de-embedded.

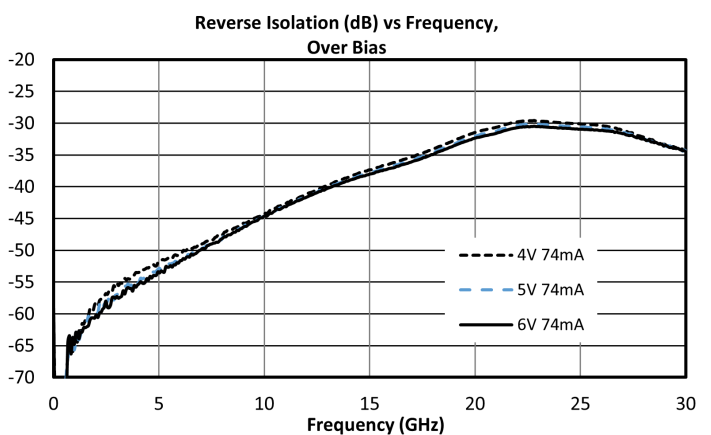
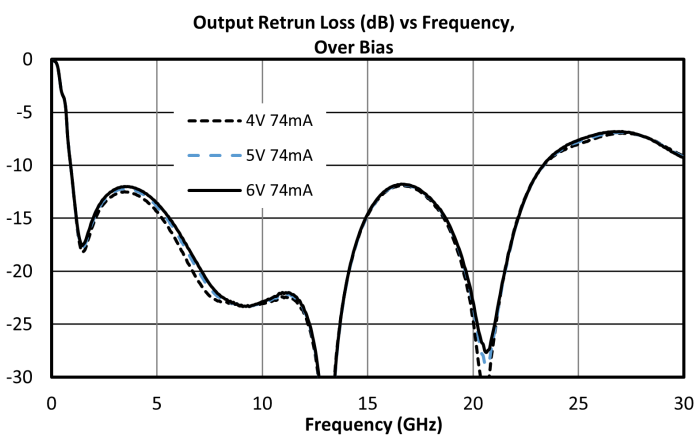
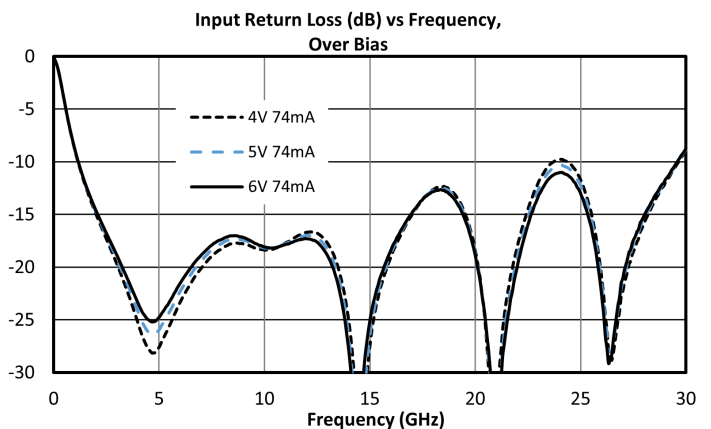
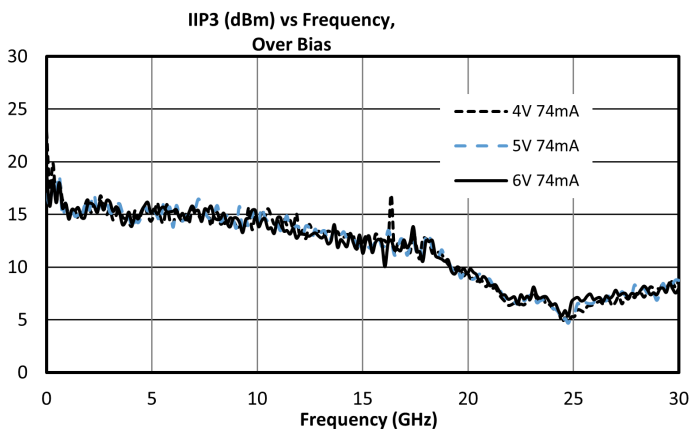
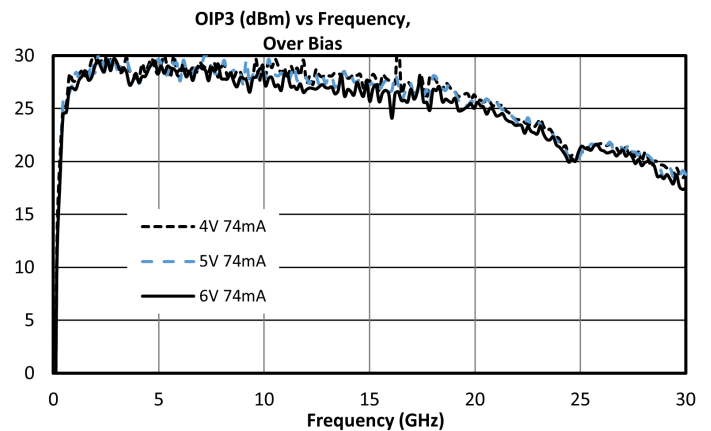
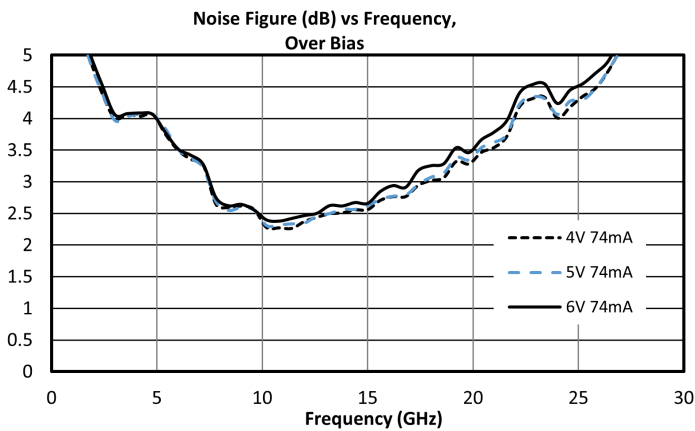
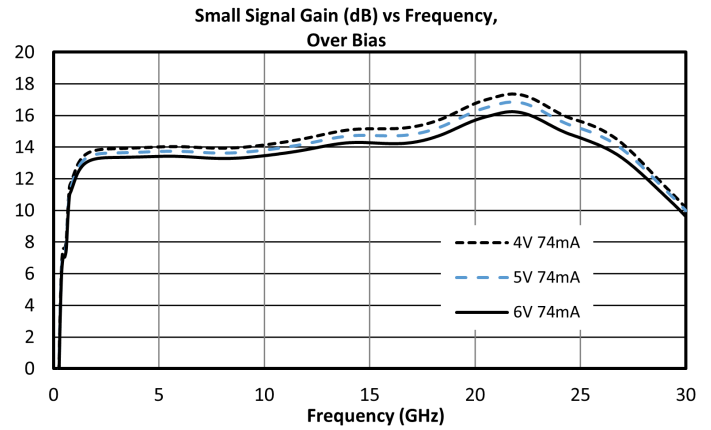
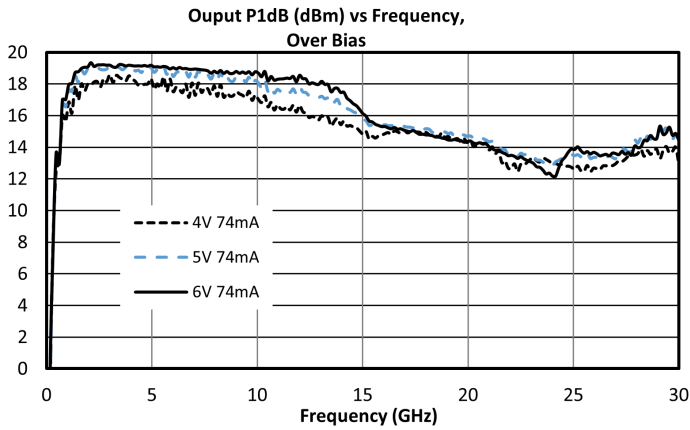

AMM-10220PSM

2 - 26 GHz GaAs Surface Mount LO Driver Amplifier

Typical Performance Plots, Over Temp

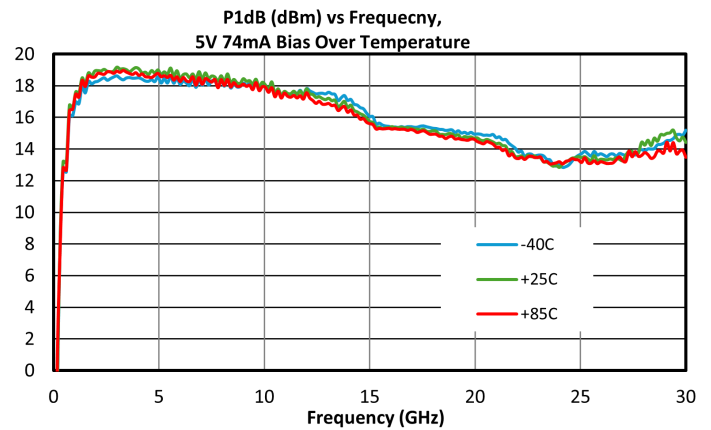
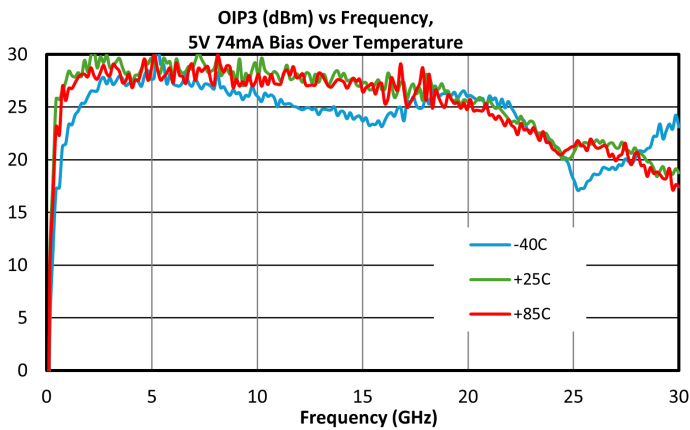
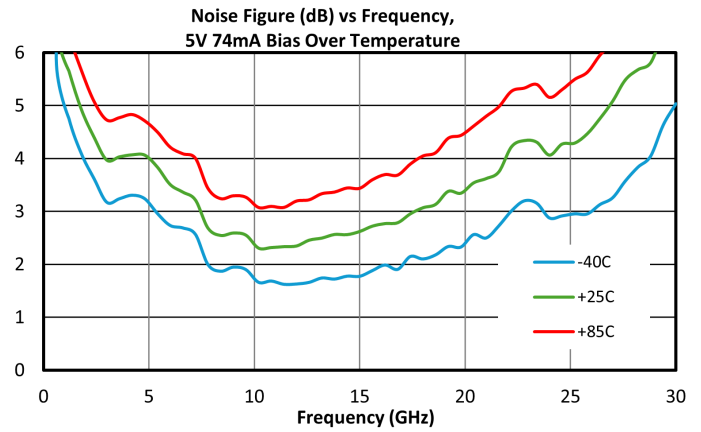
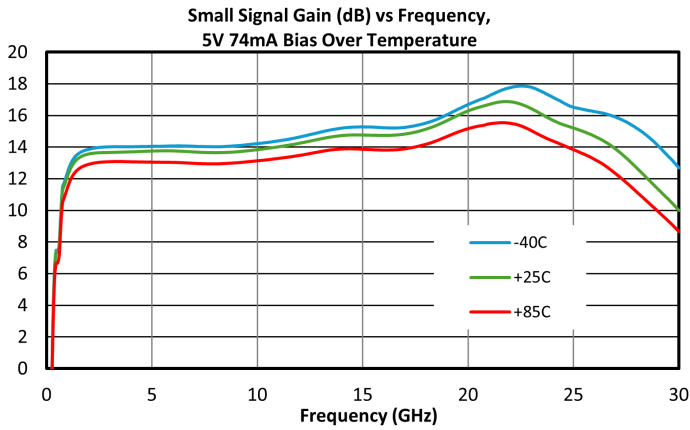

AMM-10220PSM

2 - 26 GHz GaAs Surface Mount LO Driver
Amplifier

Application Circuit

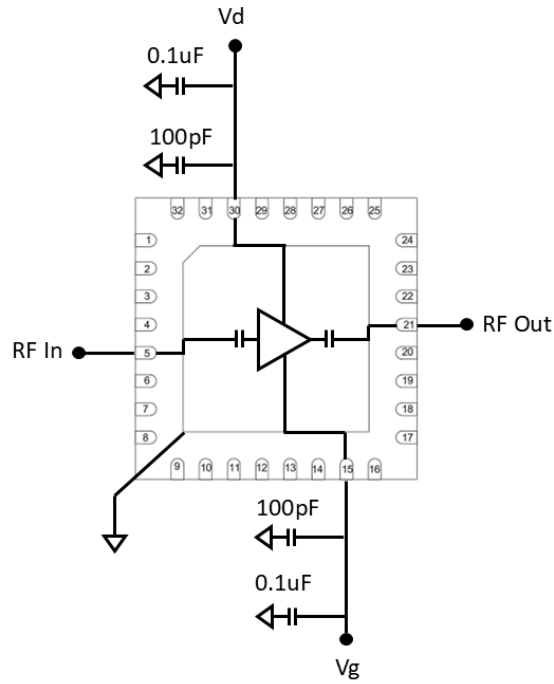

AMM-10220PSM

**2 - 26 GHz GaAs Surface Mount LO Driver
Amplifier**

Application Circuit Description

The AMM-10220PSM includes DC blocking capacitors on the RF input and output pins. The only external components required are supply bypass capacitors on the Vd and Vg lines.

AMM-10220PSM

2 - 26 GHz GaAs Surface Mount LO Driver Amplifier

Mechanical Data

Outline Drawing

Download : [Outline 2D Drawing](#) | [Outline 3D Drawing](#) | [Outline 3D STP](#)

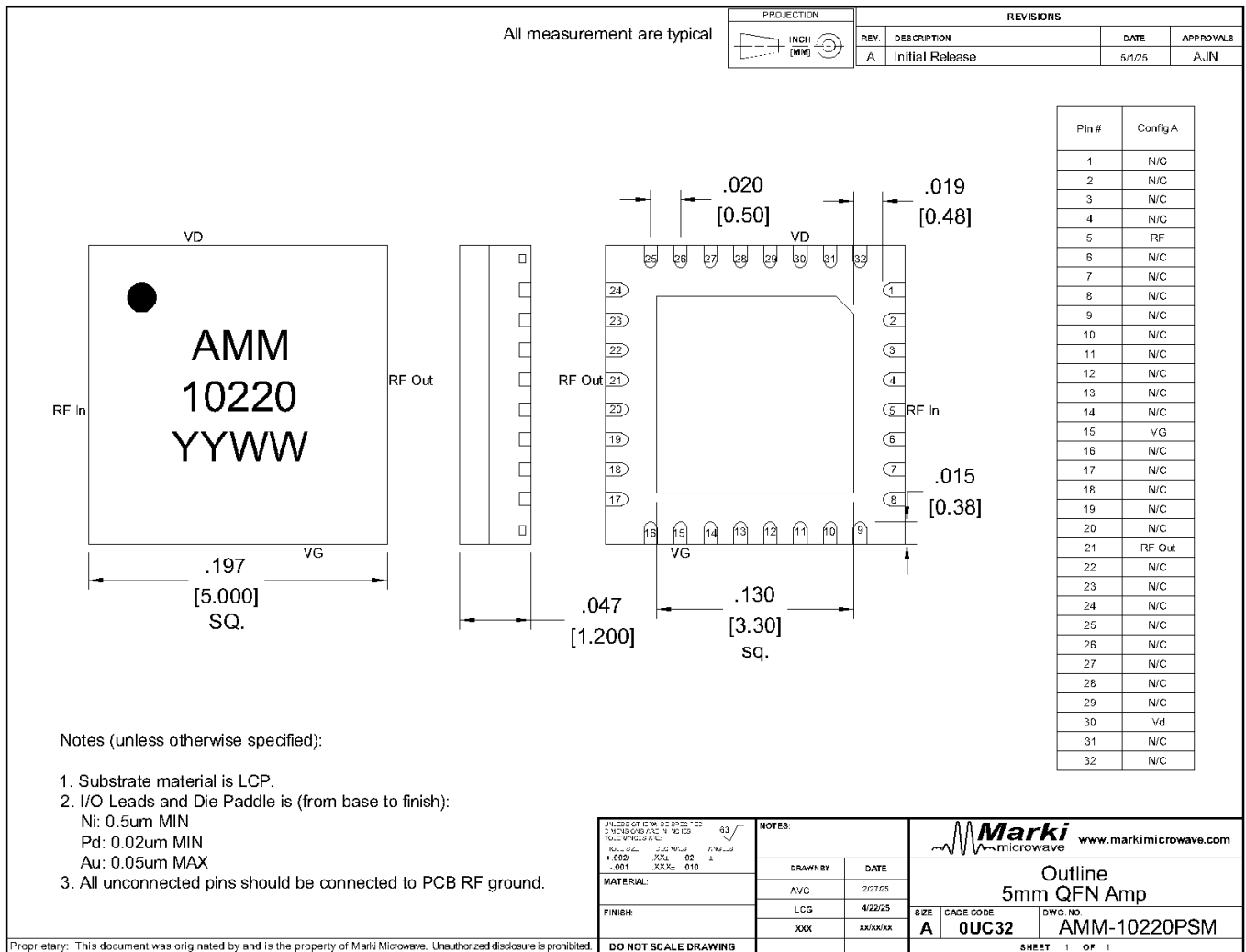

AMM-10220PSM

2 - 26 GHz GaAs Surface Mount LO Driver Amplifier

Footprint Image

Download : [Footprint Drawing](#)

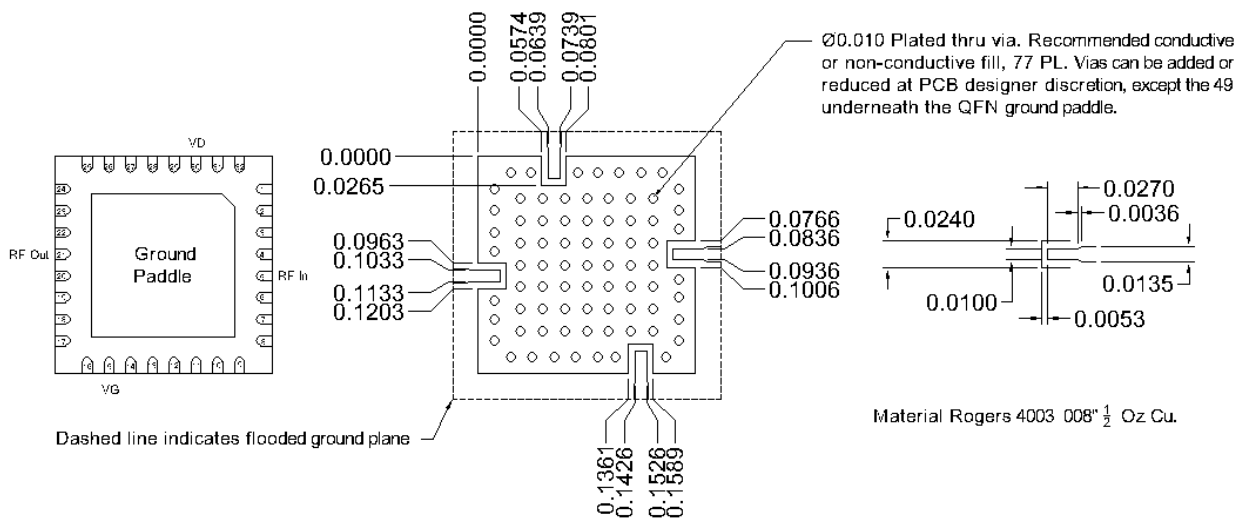

AMM-10220PSM

2 - 26 GHz GaAs Surface Mount LO Driver Amplifier

Evaluation Board - Outline Drawing

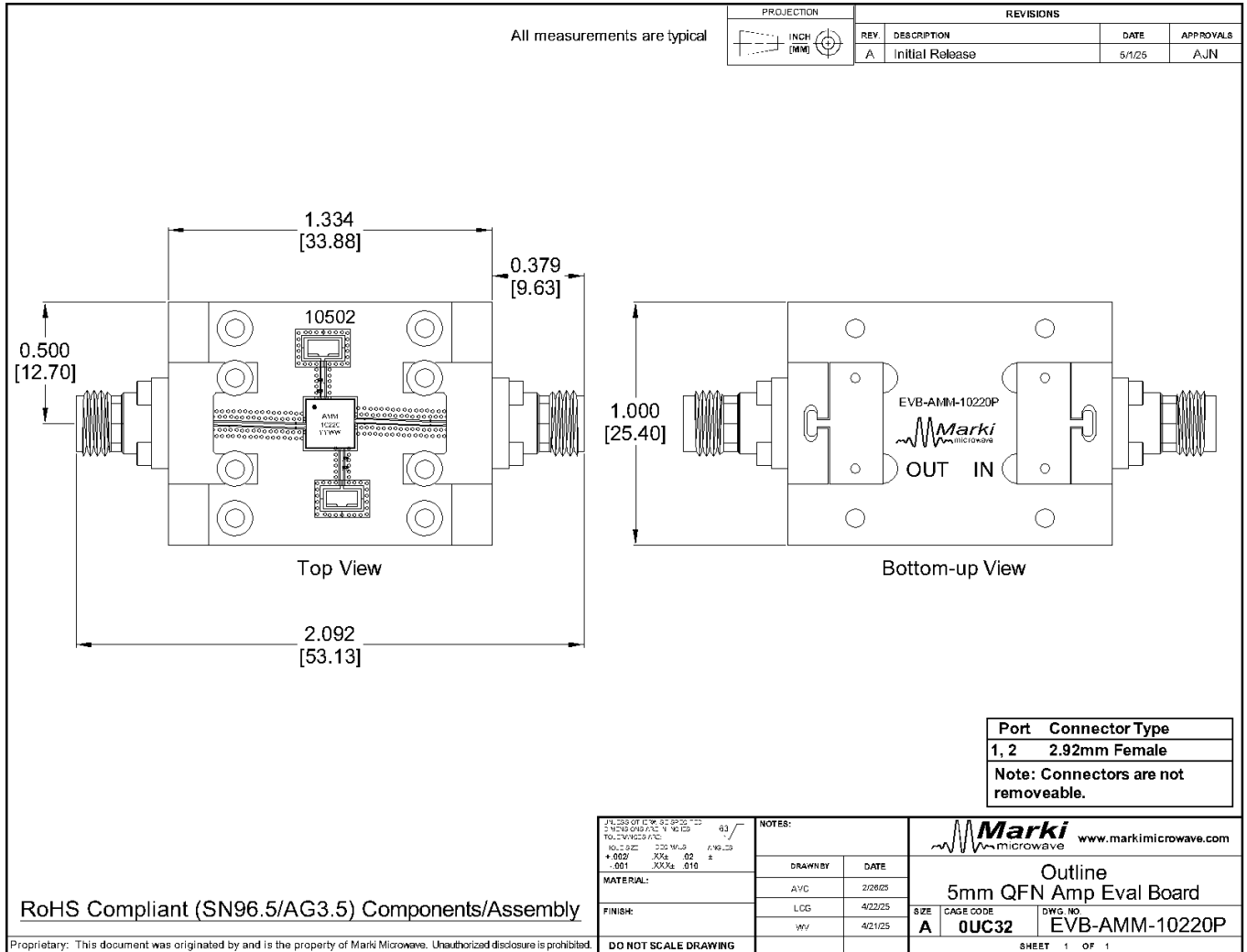

DISCLAIMER

MARKI MICROWAVE, INC., ("MARKI") PROVIDES TECHNICAL SPECIFICATIONS AND DATA (INCLUDING DATASHEETS), APPLICATION OR OTHER DESIGN ADVICE, WEB TOOLS, AND OTHER INFORMATION AND RESOURCES "AS IS" AND WITH ALL FAULTS. MARKI DISCLAIMS ALL WARRANTIES, EXPRESS OR IMPLIED, INCLUDING, WITHOUT LIMITATION, ANY IMPLIED WARRANTIES OF MERCHANTABILITY, FITNESS FOR A PARTICULAR PURPOSE, OR NON-INFRINGEMENT.

These resources are intended for developers skilled in the art designing with Marki products. You are solely responsible for (1) selecting the appropriate products for your application, (2) designing, validating, and testing your application, and (3) ensuring your application meets applicable standards and other requirements. Marki makes no guarantee regarding the suitability of its products for any particular purpose, nor does Marki assume any liability whatsoever arising out of your use or application of any Marki product.

Marki grants you permission to use these resources only for development of an application that uses Marki products. Other reproduction or use of these resources is strictly prohibited. No license is granted to any other Marki intellectual property or to any third-party intellectual property. Marki reserves the right to make changes to the product(s) or information contained herein without notice.

MARKI MICROWAVE and T3 MIXER are trademarks or registered trademarks of Marki Microwave, Inc. All other trademarks used are the property of their respective owners.

© 2025, Marki Microwave, Inc