

ADM-8344PC

DC - 18 GHz Distributed Amplifier

DEVICE OVERVIEW

General Description

The ADM-8344 is a wideband distributed low noise amplifier capable of providing 18 dB gain and +27 dBm OIP3 from DC to 18 GHz and a low 1.4 dB typical noise figure from 4 to 7 GHz. The ADM-8344 is an ideal linear signal amplifier for applications requiring low power consumption and small form-factors. ADM-8344 is available in connectorized module and can be supplied from a single positive bias. The amplifier has excellent return losses and noise figure performance.

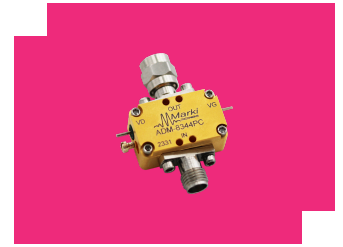

Features

- 18 dB typical gain
- 1.4 dB typical noise figure
- Single Supply, Positive Only Bias
- Low power consumption

Applications

- Test and Measurement Equipment
- Radar and satellite communications

Functional Block Diagram

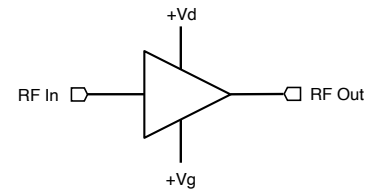

Part Ordering Options

Part Number	Description	Package	Connectors	Green Status	Product Lifecycle	Export Classification
ADM-8344PC	DC - 18 GHz Distributed Amplifier	PC	<u>Standard</u>	RoHS REACH	Released	EAR99

Table Of Contents

- **Device Overview**
 - General Description
 - Features
 - Applications
 - Functional Block Diagram
- **Port Configuration and Functions**
 - Port Diagram
 - Port Functions
- **Revision History**
- **Specifications**
 - Absolute Maximum Ratings
 - Package Information
 - Recommended Operating Conditions
 - Sequencing Requirements
 - Electrical Specifications
 - Typical Performance Plots
- **Mechanical Data**
 - Outline Drawing

Revision History

Revision Code	Revision Date	Comment
-	2023-08-01	Datasheet Initial Release
A	2025-05-10	ESD class updated

Port Configuration and Functions

Port Diagram

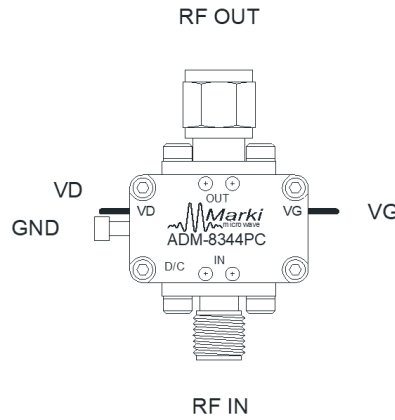

Port Functions

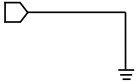
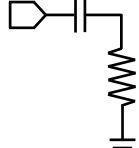
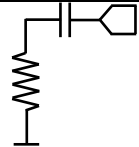
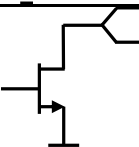
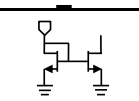
Port	Function	Connector Type	Description	Equivalent Circuit for Package
GND	Ground	-	Housing or ground lug must be connected to a DC/RF ground potential with high thermal and electrical conductivity.	
RF In	RF Input	SMAF	This is the amplifier's RF Input port. It is RF matched to 50 Ω and has built-in DC blocking capacitors.	
RF Out	RF Output	SMAM	This is the amplifier's RF Output port. It is RF matched to 50 Ω and has built-in DC blocking capacitors.	
Vd	Drain Supply Pin	-	The VD pin supplies DC voltage to the drain of the amplifier IC. This pin is nominally set at +5V.	
Vg	Gate Bias Pin	-	The VG pin provides a required positive bias which supplies the current mirror. A higher voltage results in a higher current draw through the RF Out port. This pin is nominally set at +5V.	

Specifications

Absolute Maximum Ratings

The Absolute Maximum Ratings indicate limits beyond which damage may occur to the device. If these limits are exceeded, the device may become inoperable or have a reduced lifetime. Reliability limits are individual, instantaneous catastrophic limits only. Functional operation limits are indicated below. Operation of the device at multiple absolute maximum limits or for extended periods at a single limit can cause degradation and damage to the device

Parameter	Maximum Rating	Unit
Drain Current (Id) (RF Applied)	130	mA
Drain Supply Voltage (Vd)	8.5	V
Gate Current (Ig)	10	mA
Gate Supply Voltage (Vg)	6.5	V
Maximum Operating Temperature for MTTF > 1E6 hours	85	°C
Maximum Storage Temperature	125	°C
Minimum Operating Temperature for MTTF > 1E6 hours	-40	°C
Minimum Storage Temperature	-55	°C
RF Power Handling	15	dBm

Package Information

Parameter	Details	Rating
ESD	< 250 Volts	HBM Class 0
Dimensions	-	21.85 x 13.21 mm

Recommended Operating Conditions

The Recommended Operating Conditions indicate the limits, inside which the device should be operated, to guarantee the performance given in Electrical Specifications. Operating outside these limits may not necessarily cause damage to the device, but the performance may degrade outside the limits of the electrical specifications. For limits, above which damage may occur, see Absolute Maximum Ratings.

Parameter	Min	Nominal	Max	Unit
Ambient Temperature	-40	25	85	°C
Power Supply DC Current (Id) (No RF Input)	85	103	119	mA
Power Supply DC Voltage (Vd)	4	5	8	V
Gate Bias DC Voltage (Vg)	3	5	6	V

Sequencing Requirements

There is no sequencing required to power up or power down the amplifier.

Electrical Specifications

Unless otherwise specified, electrical specifications apply at TA=+25°C, Vd = 5V, Vg = 5V.

Parameter	Test Conditions	Minimum Frequency (GHz)	Maximum Frequency (GHz)	Min	Typ	Max	Unit
DC Supply Quiescent Current (Idq)	Vd = 5V, Vg = 5V, no RF input	0	18	-	103	-	mA
Input Return Loss	Vd = 5V, Vg = 5V, Pin = -20dBm	0	18	-	15	-	dB
Noise Figure	Vd = 5V, Vg = 5V, Pin = -20dBm	0	4	-	3.2	-	dB
Noise Figure	Vd = 5V, Vg = 5V, Pin = -20dBm	4	7	-	1.4	-	dB
Noise Figure	Vd = 5V, Vg = 5V, Pin = -20dBm	7	18	-	2	-	dB
Output IP3	Vd = 5V, Vg = 5V, Pin = -20dBm	0	18	-	27	-	dBm
Output P1dB	Vd = 5V, Vg = 5V	0	18	-	18	-	dBm
Output Return Loss	Vd = 5V, Vg = 5V, Pin = -20dBm	0	18	-	25	-	dB
Reverse Isolation	Vd = 5V, Vg = 5V, Pin = -20dBm	0	18	-	40	-	dB
Small Signal Gain	Vd = 5V, Vg = 5V, Pin = -20dBm	0	18	14	18	-	dB

Typical Performance Plots

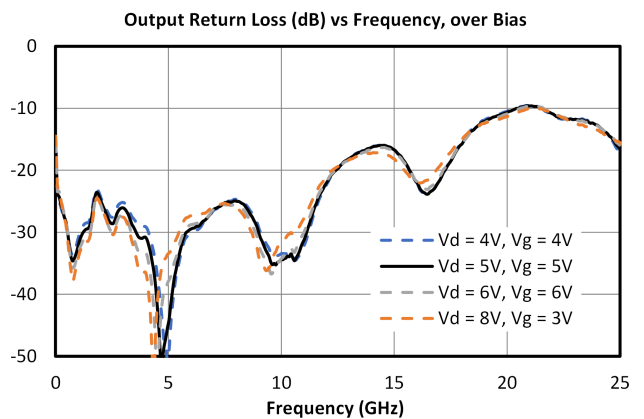
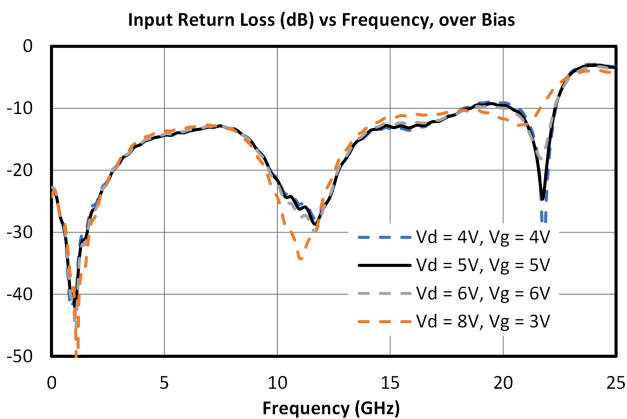
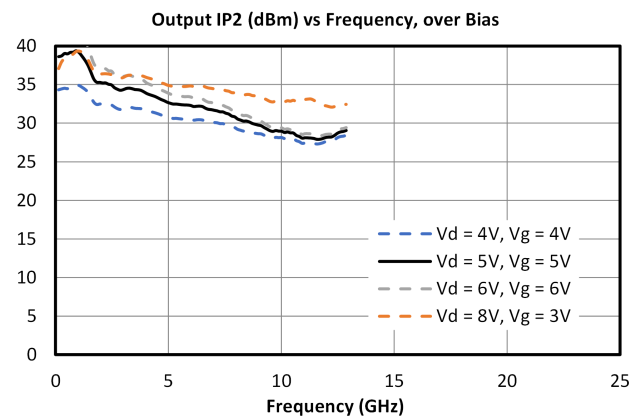
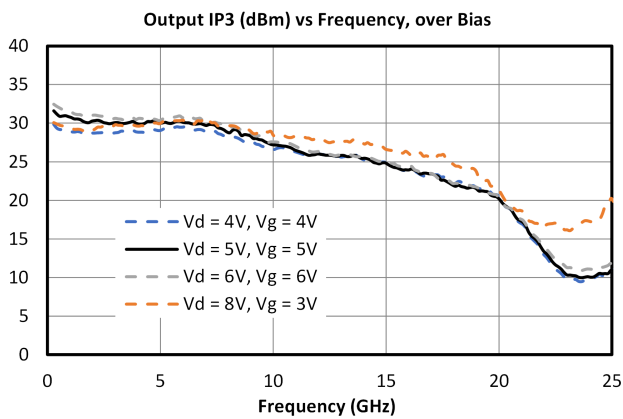
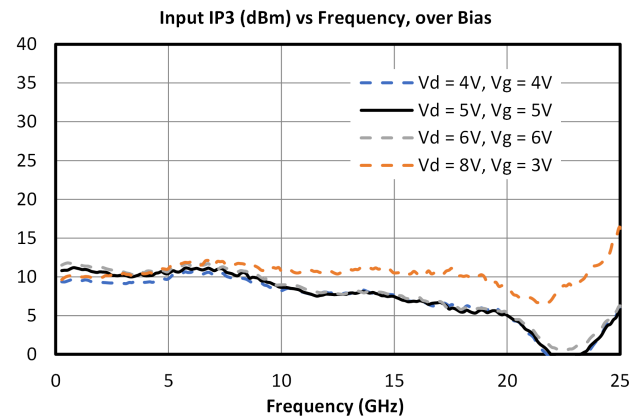
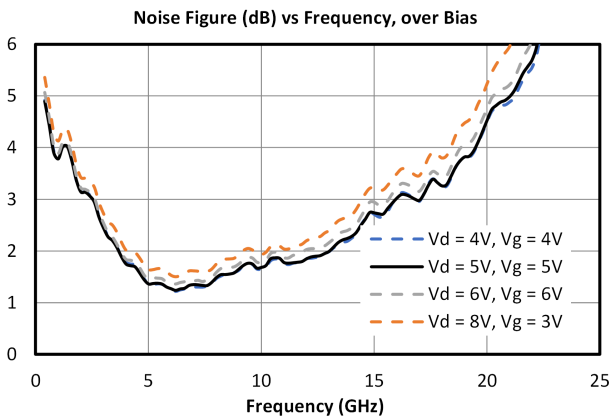
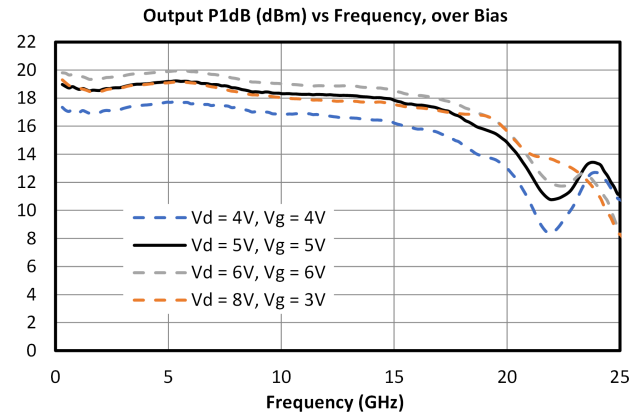
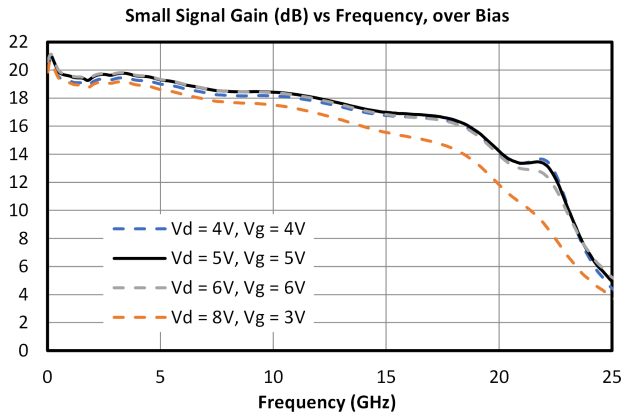

Low-Frequency Small Singal Gain (dB) vs Frequency

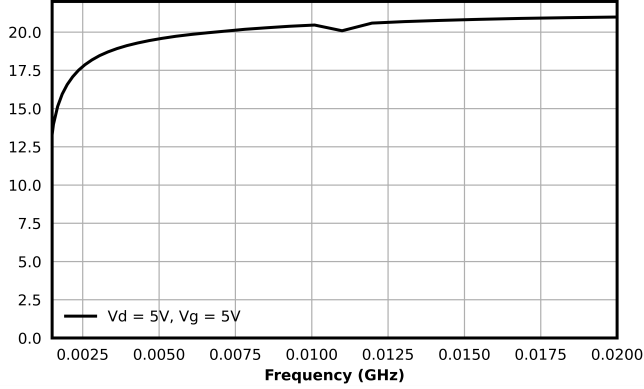

Low-Frequency Small Signal Gain (dB) vs Frequency, over Bias

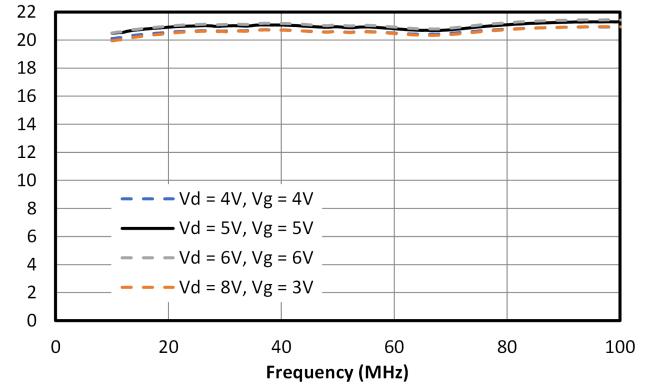

Reverse Isolation (dB) vs Frequency, over Bias

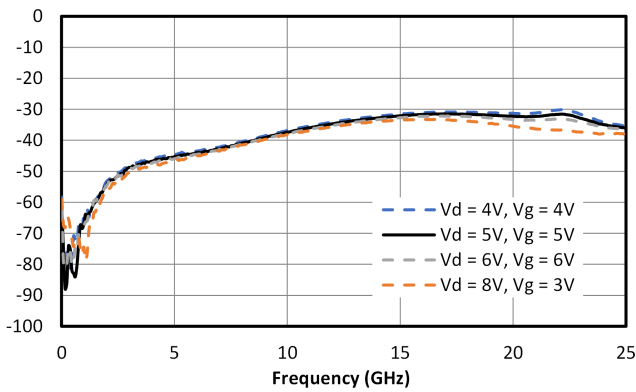

Small Signal Gain (dB) vs Frequency, over Temperature, Nom. Bias

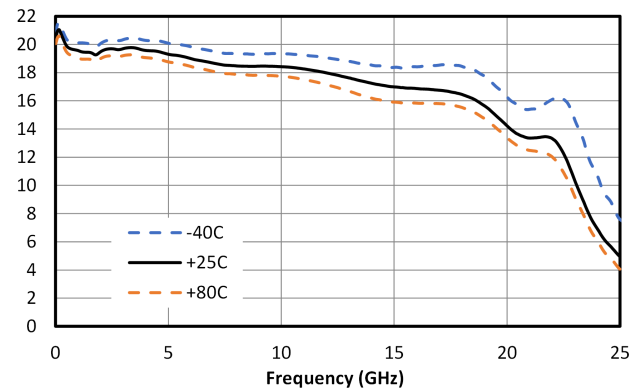

Output P1dB (dBm) vs Frequency, over Temperature, Nom. Bias

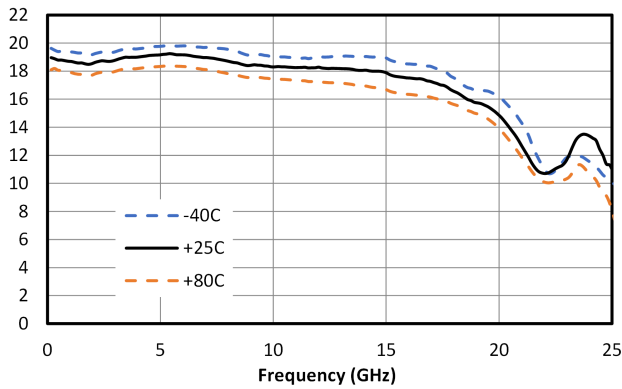

Noise Figure (dB) vs Frequency, over Temperature, Nom. Bias

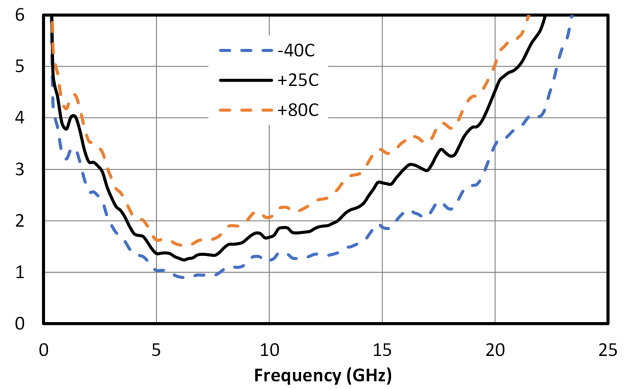

DISCLAIMER

MARKI MICROWAVE, INC., ("MARKI") PROVIDES TECHNICAL SPECIFICATIONS AND DATA (INCLUDING DATASHEETS), APPLICATION OR OTHER DESIGN ADVICE, WEB TOOLS, AND OTHER INFORMATION AND RESOURCES "AS IS" AND WITH ALL FAULTS. MARKI DISCLAIMS ALL WARRANTIES, EXPRESS OR IMPLIED, INCLUDING, WITHOUT LIMITATION, ANY IMPLIED WARRANTIES OF MERCHANTABILITY, FITNESS FOR A PARTICULAR PURPOSE, OR NON-INFRINGEMENT. These resources are intended for developers skilled in the art designing with Marki products. You are solely responsible for (1) selecting the appropriate products for your application, (2) designing, validating, and testing your application, and (3) ensuring your application meets applicable standards and other requirements. Marki makes no guarantee regarding the suitability of its products for any particular purpose, nor does Marki assume any liability whatsoever arising out of your use or application of any Marki product.

Marki grants you permission to use these resources only for development of an application that uses Marki products. Other reproduction or use of these resources is strictly prohibited. No license is granted to any other Marki intellectual property or to any third-party intellectual property. Marki reserves the right to make changes to the product(s) or information contained herein without notice.

MARKI MICROWAVE and T3 MIXER are trademarks or registered trademarks of Marki Microwave, Inc. All other trademarks used are the property of their respective owners.

© 2023, 2025, Marki Microwave, Inc